

Componenti e sistemi per l'oleodinamica  
Hydraulic Components



**BASI E BLOCCHI NG6  
SUBPLATES AND BLOCKS NG6**

**BASI E BLOCCHI NG10  
SUBPLATES AND BLOCKS NG10**

**BASI E BLOCCHI NG16  
SUBPLATES AND BLOCKS NG16**

**BASI E BLOCCHI NG25  
SUBPLATES AND BLOCKS NG25**

**BLOCCHI MODULARI  
MODULAR BLOCKS**

**VALVOLE MODULARI  
MODULAR VALVES**

**CIRCUITI INTEGRATI  
CUSTOMIZED SOLUTIONS**

**VALVOLE IN LINEA  
IN LINE VALVES**

**VALVOLE DIREZIONALI  
DIRECTIONAL VALVES**

**MICROCILINDRI  
MICROCYLINDERS**

**VALVOLE A CARTUCCIA  
CARTRIDGE VALVES**

**MINICENTRALI UPM 0,5 - 1 - 2  
POWER PACKS UPM 0,5 - 1 - 2**



**2013**

**EDIZIONE  
EDITION**



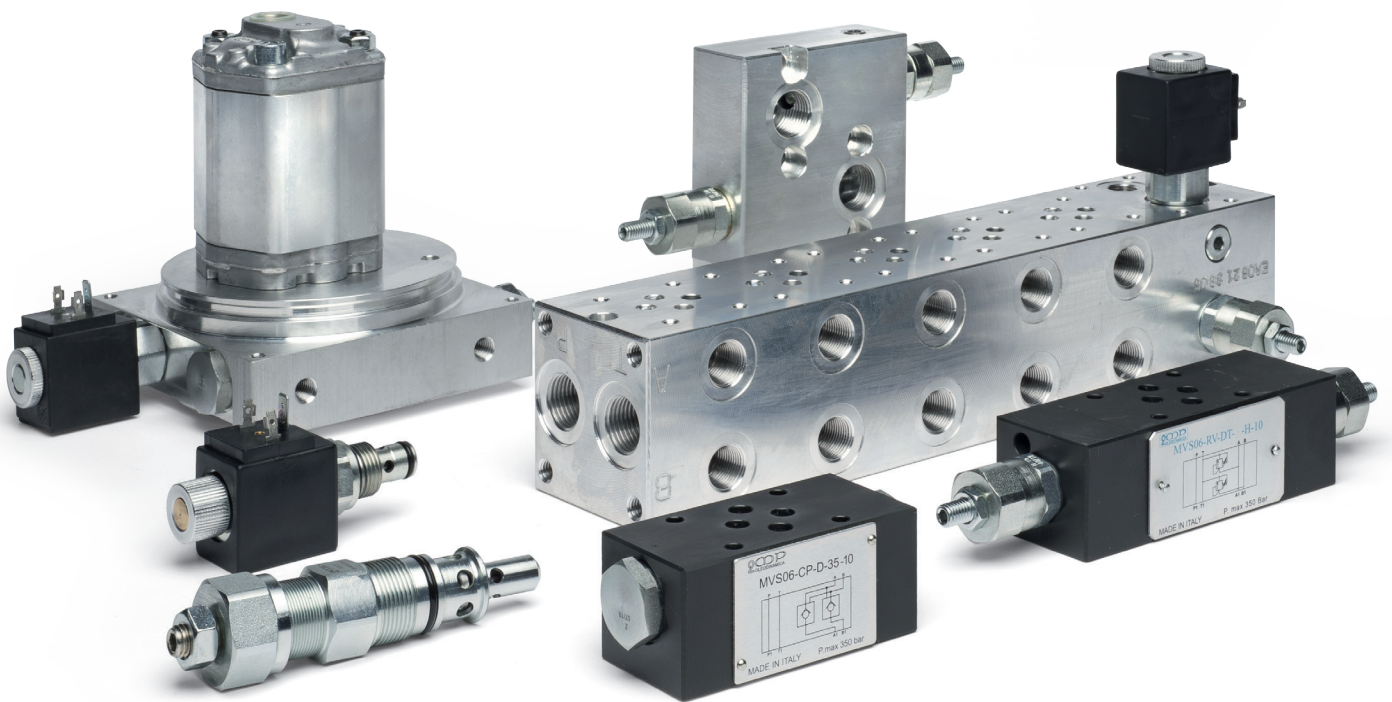

















**БелСІ  
ГПА**



**GENERAL INDEX**

**NG6**







MODEL	CODE	DESCRIPTION	A-B PORTS	P-T PORTS	RELIEF VALVE	VENTING VALVE	MATERIAL	PAGE
	E_06 - 00 - 10	BASE DI CHIUSURA END PLATE	///	///	///	///	STEEL	06.001.13
	E_06 - 00 - 20	BASE DI CHIUSURA- COLLEGAMENTO END-SUB-PLATE	///	///	///	///	ALLUMINUM STEEL	06.002.13
	E_06 - 01 - ___	BASE DI COLLEGAMENTO SUB-PLATE	LATERALI ON SIDE 3/8G - 1/4G	LATERALI ON SIDE 3/8G - 1/4G	///	///	ALLUMINUM STEEL	06.003.13
	E_610 - 06 - _	PANNELLO MOD. PER PRESSOSTATO PACKING PLATE FOR PRESSURE SWITCH	///	///	///	///	ALLUMINUM STEEL	06.004.13
	E_06 - 23 - _	CONVERTITORE PARALLELO-SERIE CONVERTER ELEMENT PARALLEL TO SERIES	///	///	///	///	ALLUMINUM STEEL	06.005.13
	E_06 - 36 - 00	BASE DI COLLEG. A/A-B/B SUB-PLATE A/A-B/B	///	///	///	///	ALLUMINUM STEEL	06.006.13
	E_06 - 02 - 38	BASE SINGOLA PER REG. DI FLUSSO SUB-PLATE FOR FLOW REGULATOR	POSTERIORI BACK 3/8G	///	///	///	ALLUMINUM STEEL	06.007.13
	E_06 - 03 - 38	BASE SINGOLA CETOP 3 SUB-PLATE CETOP 3	LATERALI ON SIDE 3/8G	POSTERIORI BACK 3/8G	C008 DRV-M20-02	///	ALLUMINUM STEEL	06.008.13
	E_06 - 07 - _	BASE SINGOLA CETOP 3 SUB-PLATE CETOP 3	///	POSTERIORI BACK 1/4G - 3/8G - 1/2G	///	///	ALLUMINUM STEEL	06.009.13
	E_06 - 08 - _	BASE SINGOLA CETOP 3 SUB-PLATE CETOP 3	LATERALI ON SIDE 1/4G - 3/8G - 1/2G	LATERALI ON SIDE 1/4G - 3/8G - 1/2G	///	///	ALLUMINUM STEEL	06.010.13
	E_06 - 09 - _	BASE SINGOLA CETOP 3 SUB-PLATE CETOP 3	LATERALI ON SIDE 1/4G - 3/8G - 1/2G	LATERALI ON SIDE 1/4G - 3/8G - 1/2G	///	///	ALLUMINUM STEEL	06.011.13
	E_06 - 10 - 38	BASE SINGOLA CETOP 3 SUB-PLATE CETOP 3	LATERALI ON SIDE 3/8G	LATERALI - POSTERIORI ON SIDE - BACK 3/8G	C008 DRV-M20-02	///	ALLUMINUM STEEL	06.012.13
	E_06 - 10 - 12	BASE SINGOLA CETOP 3 SUB-PLATE CETOP 3	LATERALI ON SIDE 1/2G	POSTERIORI BACK 1/2G	C008 DRV-M20-02	///	ALLUMINUM STEEL	06.013.13
	E_06 - 15 - _	BASE SINGOLA CETOP 3 SUB-PLATE CETOP 3	LATERALI ON SIDE 1/4G - 3/8G - 1/2G	POSTERIORI BACK 1/4G - 3/8G - 1/2G	///	///	ALLUMINUM STEEL	06.014.13
	E_06 - 16 - _	BASE SINGOLA CETOP 3 SUB-PLATE CETOP 3	LATERALI ON SIDE 1/4G - 3/8G - 1/2G	LATERALI - POSTERIORI ON SIDE - BACK 1/4G - 3/8G - 1/2G	///	///	ALLUMINUM STEEL	06.015.13
	E_06 - 22 - 38	BASE SINGOLA CETOP 3 SUB-PLATE CETOP 3	LATERALI ON SIDE 3/8G	POSTERIORI BACK 3/8G	C008 DRV-M20-02	///	ALLUMINUM STEEL	06.016.13
	E_06 - 33 - 38	BASE SINGOLA CETOP 3 SUB-PLATE CETOP 3	LATERALI ON SIDE 3/8G	POSTERIORI BACK 3/8G	C008 DRV-M20-02	///	ALLUMINUM STEEL	06.017.13
	E_06 - 40 - 38	BASE SINGOLA CETOP 3 SUB-PLATE CETOP 3	LATERALI ON SIDE 3/8G	LATERALI ON SIDE 3/8G	///	///	ALLUMINUM STEEL	06.018.13
	E_06 - 41 - 38	BASE SINGOLA CETOP 3 SUB-PLATE CETOP 3	LATERALI ON SIDE 3/8G	LATERALI ON SIDE 3/8G	///	///	ALLUMINUM STEEL	06.019.13

MODEL	CODE	DESCRIPTION	A-B PORTS	P-T PORTS	RELIEF VALVE	VENTING VALVE	MATERIAL	PAGE
	E_06 - 27 - 38	PANNELLO MODULARE A-B MODULAR PLATE A-B	LATERALI ON SIDE 3/8G	PASSANTI CROSSING 1/2G	///	///	ALLUMINUM STEEL	06.020.13
	E_06 - 29	ELEMENTO AGGIUNTIVO PER RIDUTTRICE MODULAR PLATE FOR REDUCING VALVE	///	PASSANTI CROSSING 1/2G	///	///	ALLUMINUM STEEL	06.021.13
	E_06 - 17 - 12	ELEMENTO VENTING- VALVOLA DI MASSIMA VENTING ELEMENT - RELIEF VALVE	///	PASSANTI CROSSING 1/2G	C007 DRV-S08-01	C007 SVCP-S08-TS2	ALLUMINUM STEEL	06.022.13
	E_06 - 12 - 38	MONOBLOCCO MONOBLOCK	LATERALI ON SIDE 3/8G	PASSANTI CROSSING 1/2G	///	///	ALLUMINUM STEEL	06.023.13
	E_06 - 14 - 38	MONOBLOCCO MONOBLOCK	LATERALI ON SIDE 3/8G	PASSANTI CROSSING 1/2G	C008 DRV-M20-02	C007 SVCP-S08-TS2	ALLUMINUM STEEL	06.024.13
	E_06 - 21 - 38	MONOBLOCCO MONOBLOCK	LATERALI ON SIDE 3/8G	PASSANTI CROSSING 1/2G	C008 DRV-M20-02	C007 SVCP-S08-TS2	ALLUMINUM STEEL	06.025.13
	E_06 - 39 - 38	MONOBLOCCO MONOBLOCK	LATERALI ON SIDE 3/8G	PASSANTI - POSTERIORI CROSSING - BACK 1/2G	C008 DRV-M20-02	C007 SVCP-S08-TS2	ALLUMINUM STEEL	06.026.13
	E_06 - 24 - _	ELEMENTO AGGIUNTIVO VENTING VENTING ELEMENT	///	///	///	C007 SVCP-S08-TS2	ALLUMINUM STEEL	06.027.13
	E_06 - 19 - 38	MONOBLOCCO MONOBLOCK	LATERALI ON SIDE 3/8G	PASSANTI CROSSING 1/2G	C008 DRV-M20-02	C007 SVCP-S08-TS2	ALLUMINUM STEEL	06.028.13
	E_06 - 28 - 12	MONOBLOCCO MONOBLOCK	LATERALI ON SIDE 1/2G	PASSANTI CROSSING 3/4G	C035	C035 SVCP-S10-TS2	ALLUMINUM STEEL	06.029.13
	E_06 - 30 - 12	BASE SINGOLA CETOP 3 SUB-PLATE CETOP 3	LATERALI ON SIDE 1/2G	PASSANTI CROSSING 3/4G	C025 DRV-M26-01	C035 SVCP-S10-TS2	ALLUMINUM STEEL	06.030.13
	E_06 - 13 - 38	MONOBLOCCO MONOBLOCK	POSTERIORI BACK 3/8G	PASSANTI CROSSING 1/2G	C008 DRV-M20-02	C007 SVCP-S08-TS2	ALLUMINUM STEEL	06.031.13
	E_06 - 13 - 12	MONOBLOCCO MONOBLOCK	POSTERIORI BACK 1/2G	PASSANTI CROSSING 1/2G	C008 DRV-M20-02	C007 SVCP-S08-TS2	ALLUMINUM STEEL	06.032.13
	E_06 - 25 - 38	MONOBLOCCO MONOBLOCK	LATERALI - POSTERIORI ON SIDE - BACK 3/8G	PASSANTI CROSSING 1/2G	C008 DRV-M20-02	C007 SVCP-S08-TS2	ALLUMINUM STEEL	06.033.13
	E_06 - 04	ELEMENTO VENTING VENTING ELEMENT	///	LATERALI ON SIDE T 1/2G	///	C007 SVCP-S08-TS2	ALLUMINUM STEEL	06.034.13
	E_06 - 11	ELEMENTO DI COLLEGAMENTO SINGLE SUBPLATE	LATERALI ON SIDE 1/4G - 3/8G	PASSANTI CROSSING 1/4G	///	///	ALLUMINUM STEEL	06.035.13
	E_06 - 18 - 12	MONOBLOCCO MONOBLOCK	LATERALI ON SIDE 1/2G	PASSANTI - POSTERIORI CROSSING - BACK 1/2G	C035 DRV-S10-01 DRV-S10-02 PRV-S10-01	///	ALLUMINUM STEEL	06.036.13
	E_06 - 26 - 14	MONOBLOCCO MONOBLOCK	LATERALI ON SIDE 1/4G	PASSANTI CROSSING 1/4G	///	///	ALLUMINUM	06.037.13
	E_R06 - 32 - 12	BASE SINGOLA CETOP 3 SUB-PLATE CETOP 3	///	POSTERIORI BACK T=3/4G P=1/2G	///	///	ALLUMINUM STEEL	06.038.13
	E_R08 - 35 - 100	BASE ISO/CETOP 08R SUB-PLATE ISO/CETOP 08R	///	POSTERIORI BACK 1/2G	///	///	ALLUMINUM STEEL	06.039.13
	E_R10 - 37 - 100	BASE ISO/CETOP 10R SUB-PLATE ISO/CETOP 10R	///	POSTERIORI BACK 1/2G	///	///	ALLUMINUM STEEL	06.040.13





# NG10

MODEL	CODE	DESCRIPTION	A-B PORTS	P-T PORTS	RELIEF VALVE	VENTING VALVE	MATERIAL	PAGE
	E_10 - 00 - 10	BASE DI CHIUSURA END PLATE	///	///	///	///	STEEL	10.001.13
	E_10 - 00 - 20	BASE DI CHIUSURA- COLLEGAMENTO END-SUB-PLATE	///	///	///	///	ALLUMINUM STEEL	10.002.13
	E_10 - 10 - ___	BASE DI COLLEGAMENTO SUB-PLATE	LATERALI ON SIDE 3/8G - 1/4G	LATERALI ON SIDE 3/8G - 1/4G	///	///	ALLUMINUM STEEL	10.003.13
	E_610 - 10 - _	PANNELLO MOD. PER PRESSOSTATO PACKING PLATE FOR PRESSURE SWITCH	///	///	///	///	ALLUMINUM STEEL	10.004.13
	E_610 - 05 - _	RIDUZIONE CETOP 5 / CETOP 3 REDUCING PLATE CETOP 5 / CETOP 3	///	///	///	///	ALLUMINUM STEEL	10.005.13
	E_10 - 02 - _	BASE SINGOLA CETOP 5 SUB-PLATE CETOP 5	LATERALI ON SIDE 1/2G - 3/4G	LATERALI ON SIDE 1/2G - 3/4G	///	///	ALLUMINUM STEEL	10.006.13
	E_10 - 03 - _	BASE SINGOLA CETOP 5 SUB-PLATE CETOP 5	LATERALI ON SIDE 1/2G - 3/4G	POSTERIORI BACK 1/2G - 3/4G	///	///	ALLUMINUM STEEL	10.007.13
	E_10 - 04 - _	BASE SINGOLA CETOP 5 SUB-PLATE CETOP 5	LATERALI ON SIDE 1/2G - 3/4G	POSTERIORI BACK 1/2G - 3/4G	C025 DRV-M26-01	///	ALLUMINUM STEEL	10.008.13
	E_10 - 08 - _	BASE SINGOLA CETOP 5 SUB-PLATE CETOP 5	LATERALI ON SIDE 1/2G - 3/4G	LATERALI ON SIDE 1/2G - 3/4G	C025 DRV-M26-01	///	ALLUMINUM STEEL	10.009.13
	E_10 - 09 - _	BASE SINGOLA CETOP 5 SUB-PLATE CETOP 5	LATERALI ON SIDE 1/2G - 3/4G	LATERALI - POSTERIORI ON SIDE - BACK 1/2G - 3/4G	C025 DRV-M26-01	///	ALLUMINUM STEEL	10.010.13
	E_10 - 18 - 12	BASE SINGOLA CETOP 5 SUB-PLATE CETOP 5	LATERALI ON SIDE 1/2G	LATERALI - POSTERIORI ON SIDE - BACK P=1/2G - T=3/4G	C025 DRV-M26-01	///	ALLUMINUM STEEL	10.011.13
	E_10 - 05 - ___	MONOBLOCCO MONOBLOCK	POSTERIORI BACK 1/2G - 3/4G	PASSANTI CROSSING 3/4G	C025 DRV-M26-01	///	ALLUMINUM STEEL (CAST IRON) GG40	10.012.13
	E_10 - 11 - 34	MONOBLOCCO MONOBLOCK	LATERALI ON SIDE 3/4G	PASSANTI CROSSING P=3/4G - T=1G	C019	///	ALLUMINUM CAST IRON	10.013.13
	E_10 - 06 - 12	MONOBLOCCO MONOBLOCK	LATERALI ON SIDE 1/2G	PASSANTI CROSSING 3/4G	C025 DRV-M26-01	C045 SVCP-S12-TS2	ALLUMINUM STEEL (CAST IRON) GG40	10.014.13
	E_10 - 06 - 34	MONOBLOCCO MONOBLOCK	LATERALI ON SIDE 3/4G	PASSANTI CROSSING 3/4G	C025 DRV-M26-01	C045 SVCP-S12-TS2	ALLUMINUM STEEL (CAST IRON) GG40	10.015.13





## NG16













MODEL	CODE	DESCRIPTION	A-B PORTS	P-T PORTS	RELIEF VALVE	VENTING VALVE	MATERIAL	PAGE
	E_16 - 03 - 30	BASE DI CHIUSURA - COLLEGAMENTO END PLATE	///	///	///	///	ALLUMINUM STEEL	16.001.13
	E_16 - 01 - _	BASE SINGOLA CETOP 7 SUB-PLATE CETOP 7	POSTERIORI BACK 3/4 - 1G	POSTERIORI BACK 3/4 - 1G	///	///	ALLUMINUM STEEL	16.002.13
	E_16 - 08 - 00	RIDUZIONE CETOP 7 / CETOP 5 REDUCING PLATE CETOP 7 / CETOP 5	///	///	///	///	ALLUMINUM STEEL	16.003.13
	E_16 - 02 - _	BASE SINGOLA CETOP 7 SUB-PLATE CETOP 7	LATERALI ON SIDE 3/4G - 1G - 1.1/4G	LATERALI ON SIDE 3/4G - 1G - 1.1/4G	///	///	ALLUMINUM STEEL (CAST IRON) GG40	16.004.13
	E_16 - 05 - _	BASE SINGOLA CETOP 7 SUB-PLATE CETOP 7	LATERALI ON SIDE 1G - 1.1/4G	POSTERIORI BACK 1G - 1.1/4G	C019	///	ALLUMINUM STEEL (CAST IRON) GG40	16.005.13
	E_16 - 04 - 114	MONOBLOCCO MONOBLOCK	POSTERIORI BACK 1.1/4G	PASSANTI CROSSING P=1.1/4G - T=1.1/2G	///	///	ALLUMINUM STEEL (CAST IRON) GG40	16.006.13
	E_16 - 06 - 100	MONOBLOCCO MONOBLOCK	LATERALI ON SIDE 1G	PASSANTI CROSSING P=1.1/4G - T=1.1/2G	C019	///	ALLUMINUM STEEL (CAST IRON) GG40	16.007.13

## NG25

MODEL	CODE	DESCRIPTION	A-B PORTS	P-T PORTS	RELIEF VALVE	VENTING VALVE	MATERIAL	PAGE
	E_25 - 00 - 30	BASE DI CHIUSURA - COLLEGAMENTO END PLATE	///	///	///	///	ALLUMINUM STEEL	25.001.13
	E_25 - 01 - _	BASE SINGOLA CETOP 8 SUB-PLATE CETOP 8	LATERALI ON SIDE 1.1/2G - 1.1/4G	LATERALI - POSTERIORI ON SIDE - BACK 1.1/2G - 1.1/4G	C019	///	ALLUMINUM STEEL	25.002.13
	E_25 - 05 - 114	BASE SINGOLA CETOP 8 SUB-PLATE CETOP 8	LATERALI ON SIDE 1.1/4G	LATERALI ON SIDE P=1.1/4G - T=1.1/2G	///	///	ALLUMINUM STEEL	25.003.13
	E_25 - 03 - 114	BASE SINGOLA CETOP 8 SUB-PLATE CETOP 8	LATERALI -SAE- ON SIDE -SAE- SAE 6000 1.1/4	LATERALI -SAE- ON SIDE -SAE- T=SAE 3000 1.1/2" P= SAE 6000 1.1/4	///	///	ALLUMINUM STEEL	25.004.13
	E_25 - 02 - 114	MONOBLOCCO MONOBLOCK	POSTERIORI BACK 1.1/4G	PASSANTI CROSSING 1.1/2G	///	///	ALLUMINUM STEEL	25.005.13

## MODULAR BLOCKS

MODEL	CODE	DESCRIPTION	A-B PORTS	P-T PORTS	RELIEF VALVE	VENTING VALVE	MATERIAL	PAGE
	E_610-08-38	BASE MODULARE CETOP 3 MODULAR PLATE CETOP 3	POSTERIORI BACK 3/8G	PASSANTI CROSSING 1/2G	C035 DRV-S10-01	///	ALLUMINUM STEEL	MB.001.13
	E_610-09-38	BASE MODULARE CETOP 3 MODULAR PLATE CETOP 3	POSTERIORI BACK 3/8G	PASSANTI CROSSING 3/8G	///	///	ALLUMINUM STEEL	MB.002.13
	E_610-11-_	BASE MODULARE CETOP 3 MODULAR PLATE CETOP 3	///	PASSANTI CROSSING 3/8G	///	///	ALLUMINUM STEEL	MB.003.13
	E_610-12-_	BASE MODULARE CETOP 3 MODULAR PLATE CETOP 3	POSTERIORI BACK 3/8G	PASSANTI CROSSING 3/8G	///	C007 SVCP-S08-TS4 SVCP-S08-TS3 SVCP-S08-TD3	ALLUMINUM STEEL	MB.004.13
	E_610-19-12	BASE MODULARE CETOP 5 MODULAR PLATE CETOP 5	POSTERIORI BACK 1/2G	PASSANTI CROSSING 1/2G	///	///	ALLUMINUM STEEL	MB.005.13

MODEL	CODE	DESCRIPTION	A-B PORTS	P-T PORTS	RELIEF VALVE	VENTING VALVE	MATERIAL	PAGE
	E_ 610-20-38	BASE MODULARE CETOP 3 MODULAR PLATE CETOP 3	POSTERIORI BACK 3/8G	PASSANTI CROSSING 3/8G	///	///	ALLUMINUM STEEL	MB.006.13
	E_ 610-21-38	BASE MODULARE CETOP 3 MODULAR PLATE CETOP 3	POSTERIORI BACK 3/8G	PASSANTI CROSSING 3/8G	///	///	ALLUMINUM STEEL	MB.007.13
	E_ 610-22	BASE MODULARE CON RITEGNO MODULAR PLATE WITH CHECK VALVE	///	PASSANTI CROSSING 1/2G	///	///	ALLUMINUM STEEL	MB.008.13
	E_ 610-23-38	BASE MODULARE CETOP 3 MODULAR PLATE CETOP 3	POSTERIORI BACK 3/8G	PASSANTI CROSSING 3/8G	///	///	ALLUMINUM STEEL	MB.009.13
	E_ 610-24-12	BASE MODULARE CETOP 5 MODULAR PLATE CETOP 5	LATERALI ON SIDE 1/2G	PASSANTI CROSSING P=1/2G T=3/4G	C035 DRV-S10-01	///	ALLUMINUM STEEL	MB.010.13
	E_ 610-25-12	BASE MODULARE CETOP 5 MODULAR PLATE CETOP 5	LATERALI ON SIDE 1/2G	PASSANTI CROSSING 1/2G	///	///	ALLUMINUM STEEL	MB.011.13
	E_ 610-26-34	BASE MODULARE CETOP 5 MODULAR PLATE CETOP 5	POSTERIORI BACK 3/4G	PASSANTI CROSSING 1/2G	///	///	ALLUMINUM STEEL	MB.012.13
	E_ 610-27-12	BASE MODULARE CETOP 3 MODULAR PLATE CETOP 3	POSTERIORI BACK 1/2G	PASSANTI CROSSING 1/2G	///	///	ALLUMINUM STEEL	MB.013.13
	E_ 610-28-12	BASE MODULARE CETOP 3 MODULAR PLATE CETOP 3	LATERALI ON SIDE 3/8G	PASSANTI CROSSING 1/2G	///	///	ALLUMINUM STEEL	MB.014.13
	E_ 610-29-12	BASE MODULARE MODULAR PLATE	///	PASSANTI CROSSING P=1/2G T=3/4G	C035 DRV-S10-01	///	ALLUMINUM STEEL	MB.015.13
	E_ 610-30-12	ELEMENTO COMPONENTE CETOP 5 MODULAR PLATE FOR PACKING CETOP 5	///	PASSANTI CROSSING P=1/2G T=3/4G	///	///	ALLUMINUM STEEL	MB.016.13
	E_ 610-31-38	PANNELLO MODULARE CETOP 3 ALTA-BASSA PRESSIONE MODULAR PLATE HI-LOW PRESSURE CETOP 3	POSTERIORI BACK 3/8G	LATERALI ON SIDE AP=3/8G - BP=1/2G - T=1/2G	C035 DRV-S10-01 DRV-S10-02 PRV-S10-01	///	ALLUMINUM STEEL	MB.017.13
	E_ 610-32-34	PANNELLO MODULARE CETOP 5 ALTA-BASSA PRESSIONE MODULAR PLATE HI-LOW PRESSURE CETOP 5	POSTERIORI BACK 3/4G	LATERALI ON SIDE AP=1/2G - BP=3/4G - T=3/4G	C035 DRV-S10-01 DRV-S10-02 PRV-S10-01	///	ALLUMINUM STEEL	MB.018.13

## CAVITY

SIZE	WAY	CODE	PAGE
M20x1,5	2	C008	CY.001.13
3/4-16 UNF	2	C007	CY.001.13
7/8-14 UNF	2	C035	CY.002.13
1.1/16-12 UNF	2	C045	CY.002.13
M26x1,5	2	C025	CY.003.13
M26x1,5	2	C019	CY.003.13
1/8G	1	BSP 1/8G	CY.004.13
1/4G	1	BSP 1/4G	CY.004.13
3/8G	1	BSP 3/8G	CY.004.13
1/2G	1	BSP 1/2G	CY.004.13
3/4G	1	BSP 3/4G	CY.005.13
1G	1	BSP 1G	CY.005.13
1.1/4G	1	BSP 1.1/4G	CY.005.13
1.1/2G	1	BSP 1.1/2G	CY.005.13

**BASE DI CHIUSURA CETOP 3**  
**END-PLATE CETOP 3**

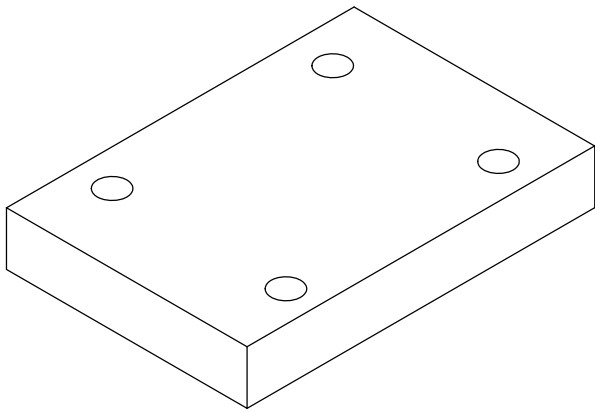

Schema idraulico  
Hydraulic diagram

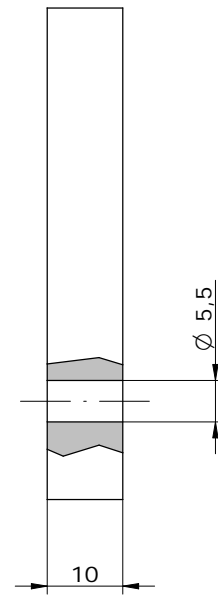
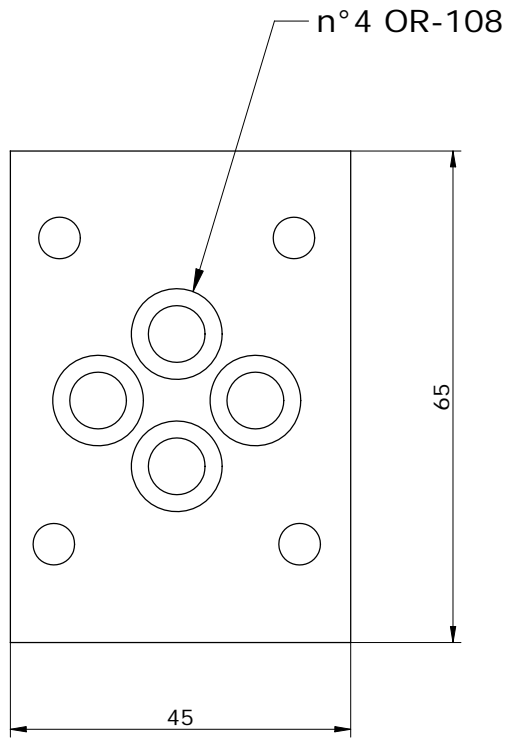
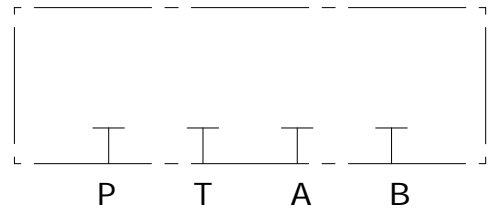

**E\_06 - 00 - 10**

**S = STEEL**



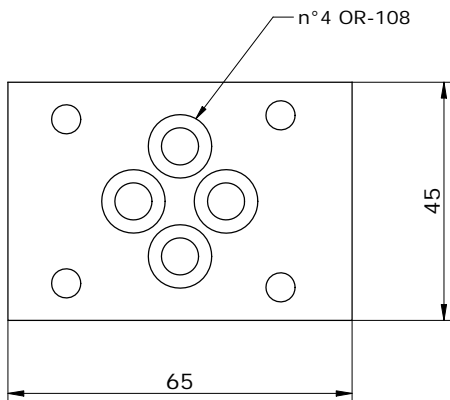
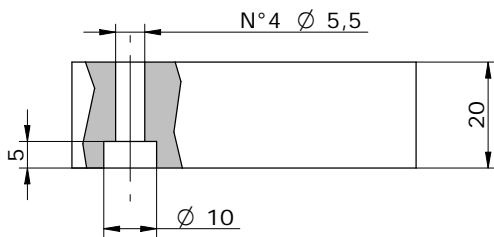
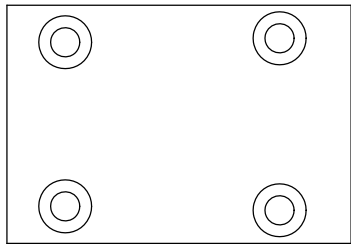
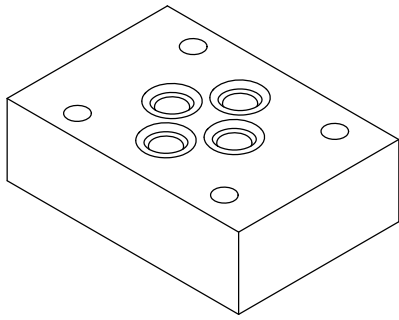

Schema idraulico  
 Hydraulic diagram

**0**

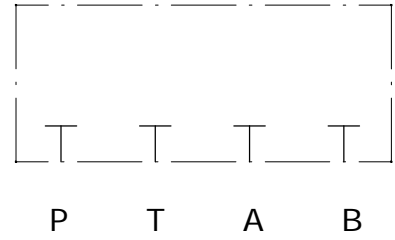

**1**

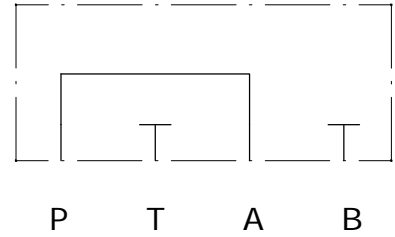

**2**

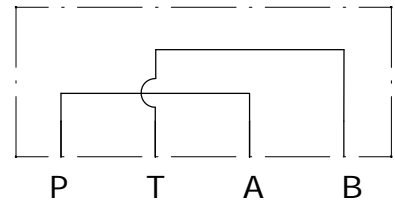

**3**

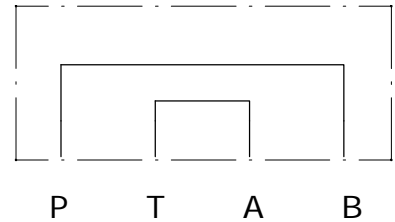

**4**

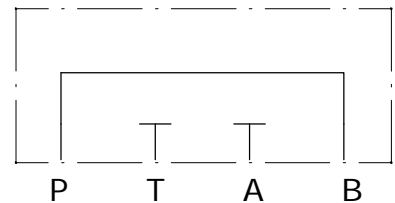

**E\_ 06 - 00 - 20 -**

**S** = STEEL  
**A** = ALUMINUM

SEE DIAGRAMS

**BASE DI COLLEGAMENTO CETOP 3 CON ATTACCHI 1/4" / (3/8") BSP**  
**SUB-PLATE CETOP 3 WITH 1/4" / (3/8") BSP PORTS**

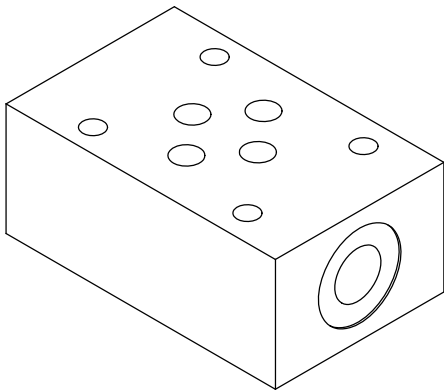

COD.	DIAGRAMS	
1	A+B	STANDARD
2	A	ON REQUEST
3	B	ON REQUEST
4	P+T	STANDARD
5	P	ON REQUEST
6	T	ON REQUEST
7	P+P	ON REQUEST
8	T+T	ON REQUEST

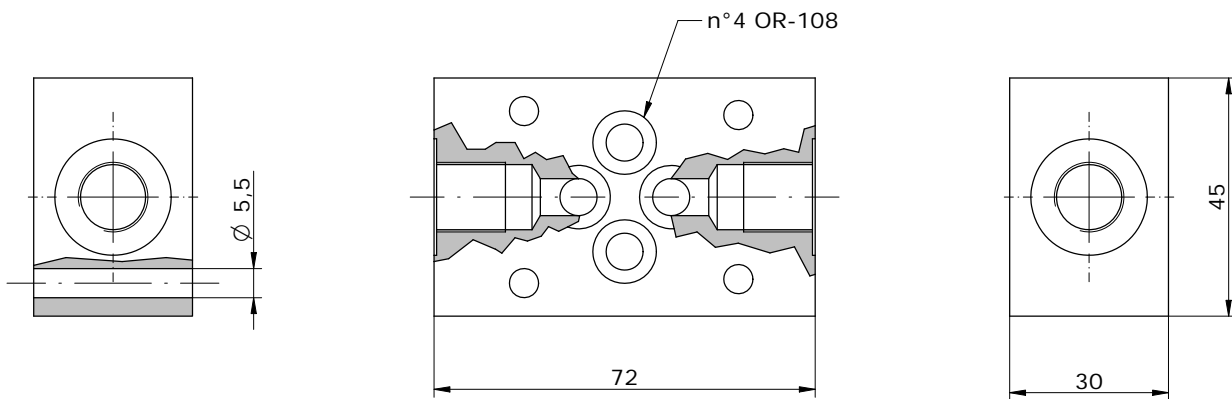
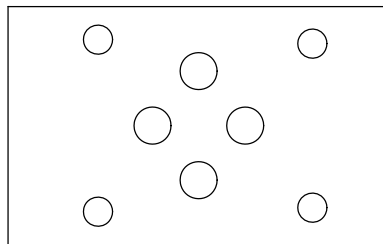

**E\_06 - 01 - \_ - \_**

**S = STEEL**  
**A = ALUMINUM**

SEE DIAGRAMS

**14 = BSP 1/4G**  
**38 = BSP 3/8G**

**PANNELLO MODULARE CETOP 3 PER PRESSOSTATO**  
**PACKING PLATE CETOP 3 FOR PRESSURE SWITCH**

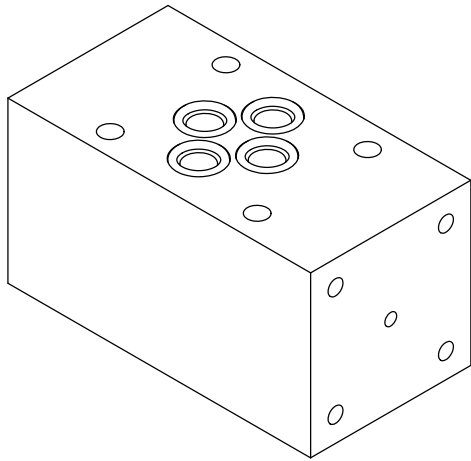

COD.	DIAGRAMS	
	1	A+B
2	A	STANDARD
3	B	STANDARD
4	P+T	ON REQUEST
5	P	STANDARD
6	T	ON REQUEST
7	P+P	ON REQUEST

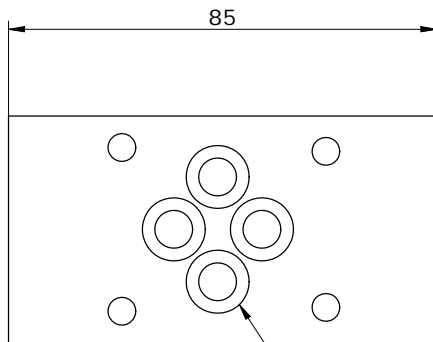
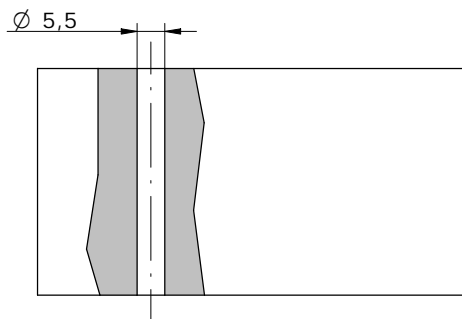

n°4 OR-108

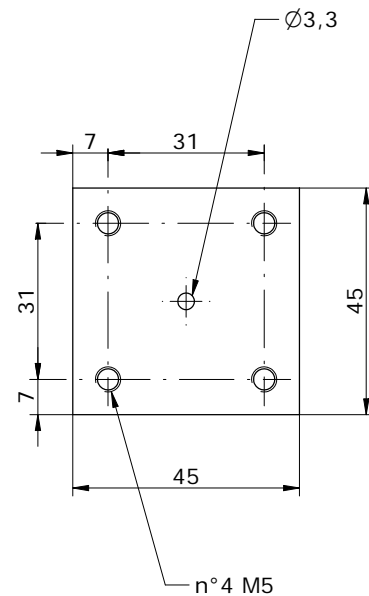

**E\_ 610 - 06 -**

**S = STEEL**  
**A = ALUMINUM**

SEE DIAGRAMS

**ELEMENTO CONVERTITORE PARALLELO - SERIE**  
**CONVERTER ELEMENT PARALLEL TO SERIES**

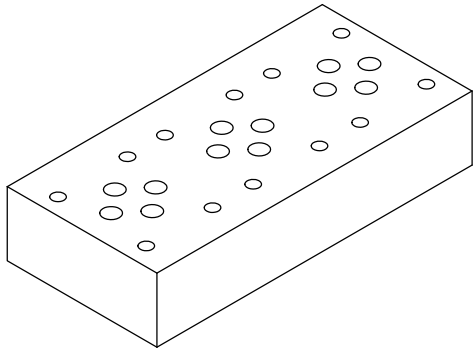

Schema idraulico  
 Hydraulic diagram

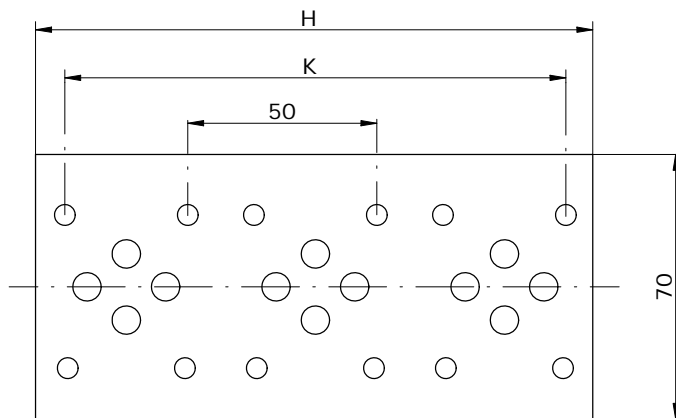
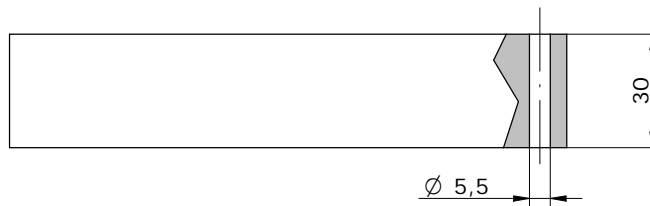
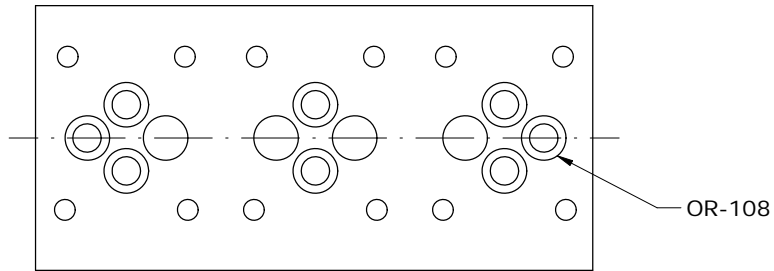
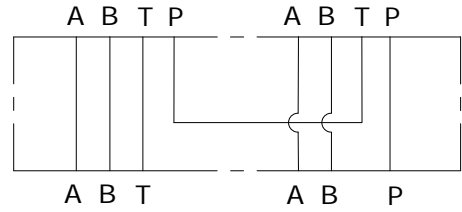

POS.	01	02	03	04	05
H	//	97	147	197	247
K	//	83	133	183	233

**E\_ 06 - 23 - \_\_\_\_\_**

**S** = STEEL  
**A** = ALUMINUM

MOUNTING POSITIONS: 02 ÷ 05

**BASE DI COLLEGAMENTO CETOP3 - A/A-B/B**  
**SUB-PLATE CETOP3 - A/A-B/B**

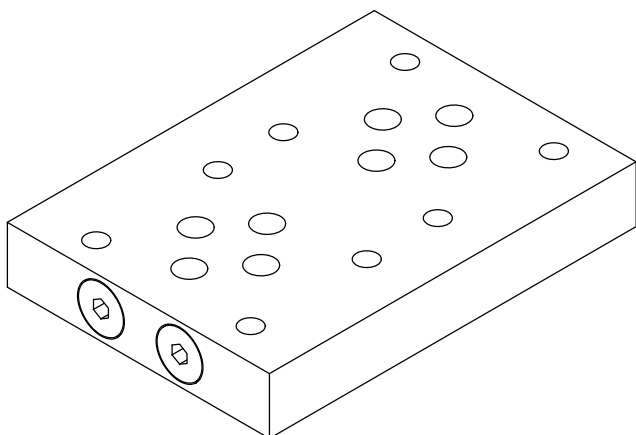

**SCHEMA IDRAULICO**  
**HYDRAULIC DIAGRAM**

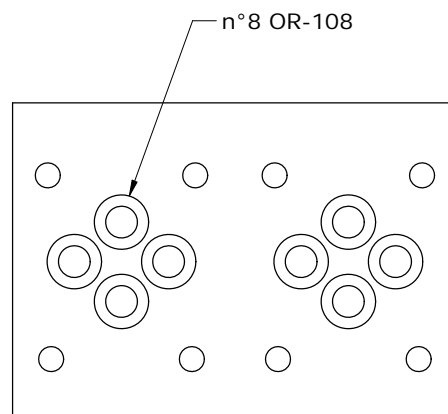
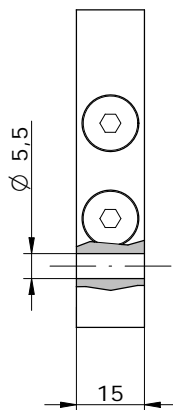
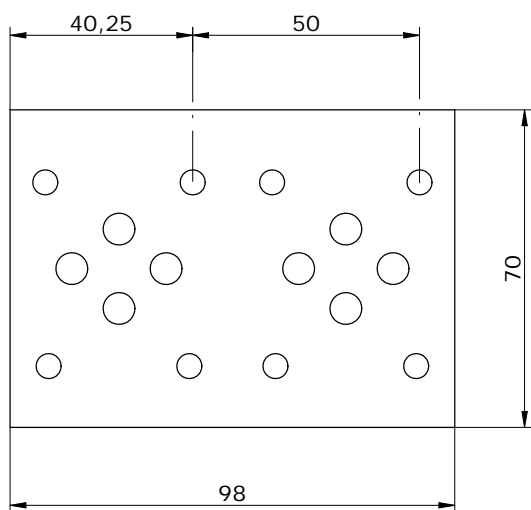
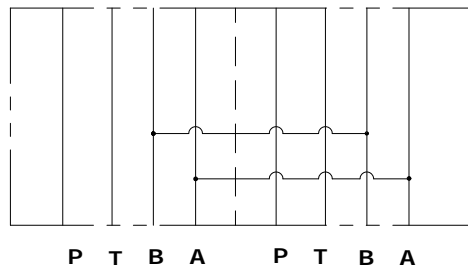

**E\_06 - 36 - 00**

**S = STEEL**  
**A = ALUMINUM**

**BASE SINGOLA CETOP 3 CON UTILIZZI A-B POST. 3/8" BSP PER REGOLAT. DI FLUSSO**  
**SUB-PLATE CETOP 3 WITH A-B PORTS BACK 3/8" BSP FOR FLOW REGULATOR**

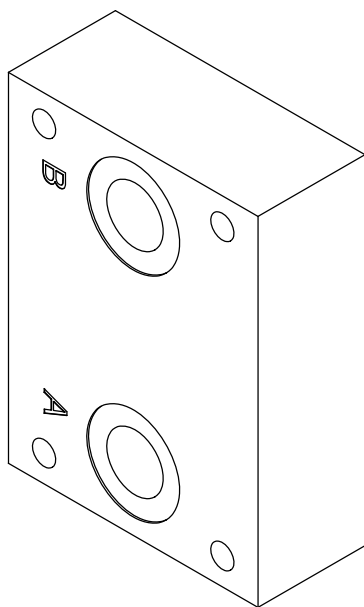

Schema idraulico  
Hydraulic diagram

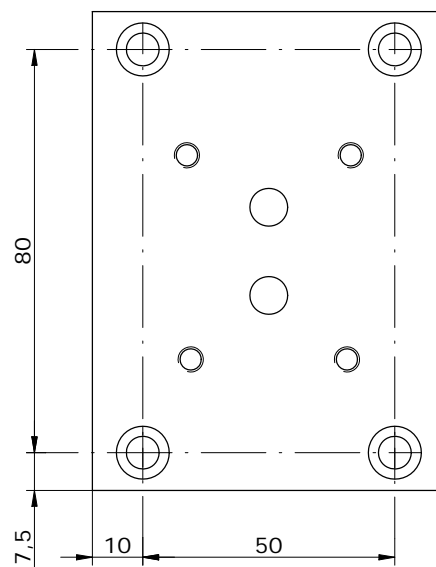
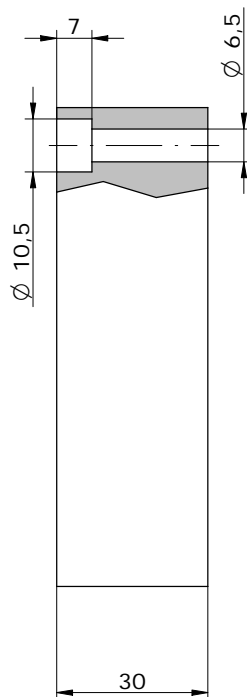
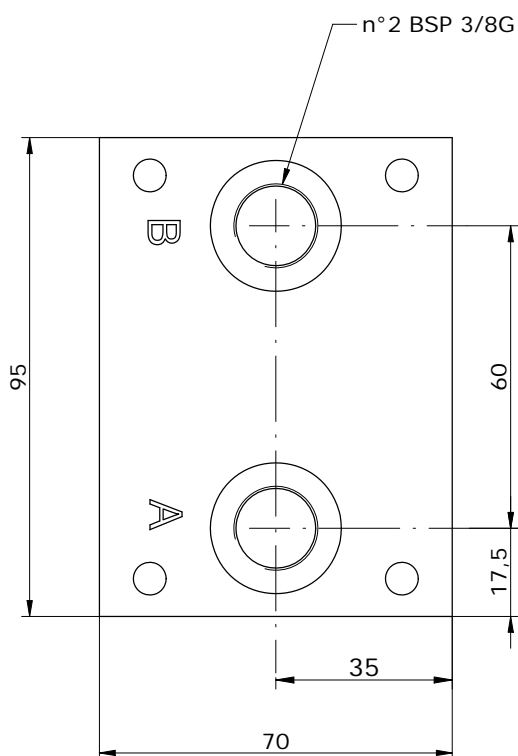
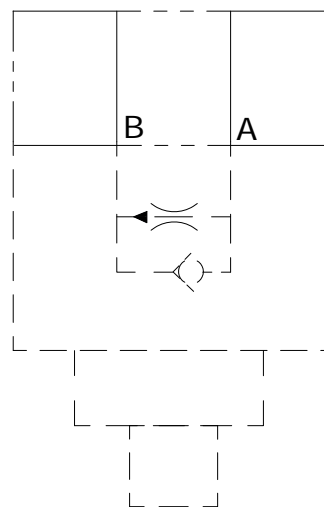

**E\_06 - 02 - 38**

**S = STEEL**  
**A = ALUMINUM**

**BASE SINGOLA CETOP 3 CON UTILIZZI A-B LAT. P-T POST. 3/8" BSP  
SUB-PLATE CETOP 3 WITH A-B PORTS ON SIDE P-T BACK 3/8" BSP**

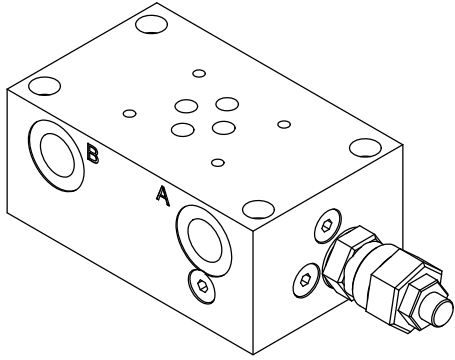

Schema idraulico  
Hydraulic diagram

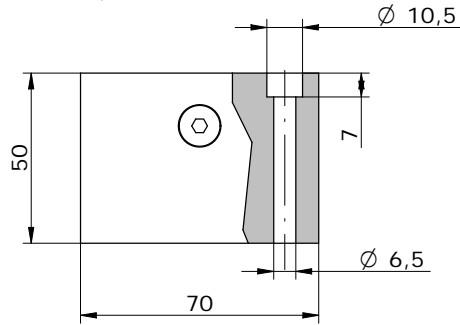
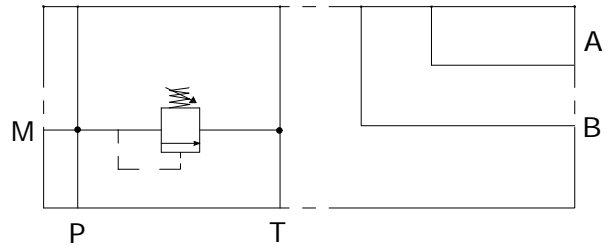

**TIPI DI REGOLAZIONE  
REGULATION TYPE**

	<b>H</b>	VITE CON CHIAVE ESAGONALE (standard) HEXAGONAL HEAD SCREW
	<b>K</b>	POMOLO KNOB
	<b>C</b>	FISSA CON CAPPUCCIO COVER CAP
	<b>I</b>	INVIOLABILE NON ADJUSTABLE

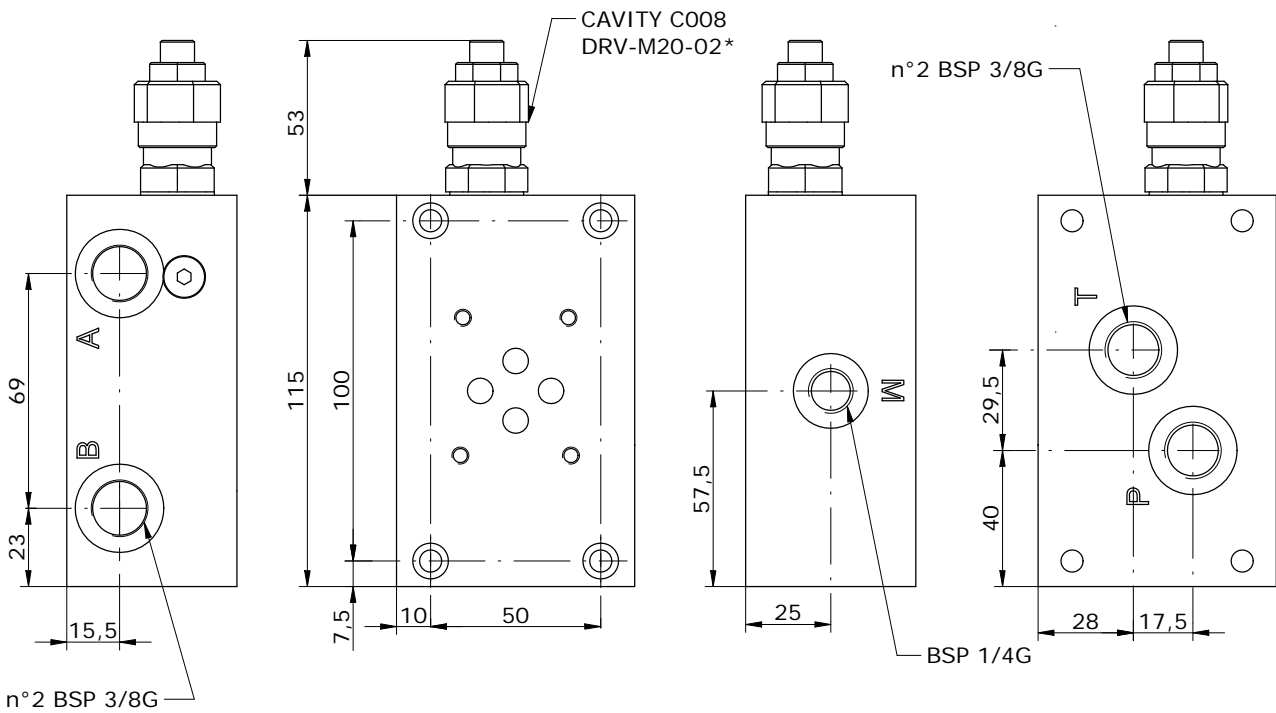

**E\_ 06 - 03 - 38- - - -**

**S** = STEEL  
**A** = ALUMINUM

**0** = WITHOUT RELIEF VALVE  
**1** = WITH RELIEF VALVE  
**2** = RELIEF VALVE READY

**OMIT**  
**H** = HEXAGONAL HEAD SCREW  
**K** = KNOB  
**C** = COVER CAP  
**I** = NOT ADJUSTABLE

**0** = WITHOUT R.V.  
**1** = 5-50 BAR  
**2** = 20-110 BAR  
**3** = 50-220 BAR  
**4** = 100-350 BAR  
**5** = 100-420 BAR

\*see **CARTDRIGE VALVES** catalog

WWW.GPA.BY

**BASE SINGOLA CETOP 3 CON UTILIZZI A-B-P-T POSTERIORI**  
**SUB-PLATE CETOP 3 WITH A-B-P-T PORTS BACK**

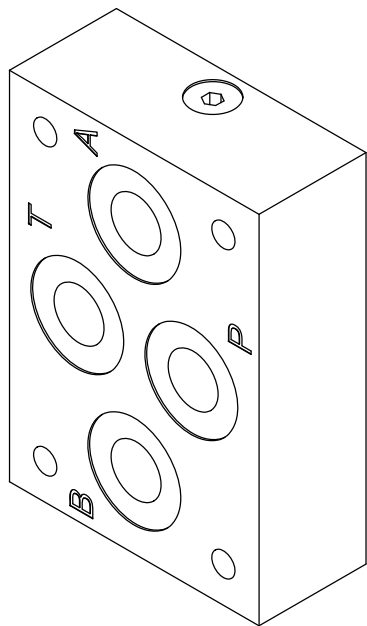

Schema idraulico  
Hydraulic diagram

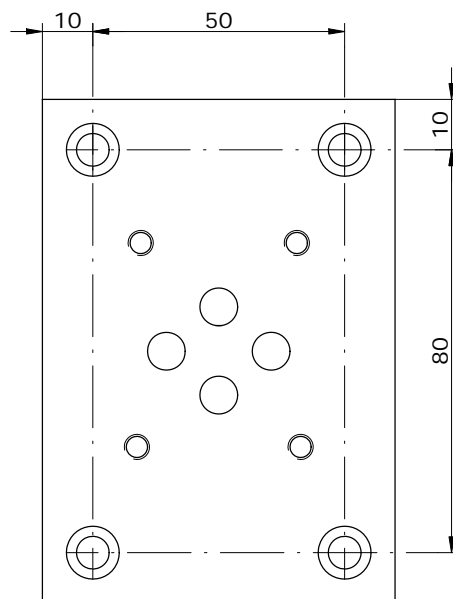
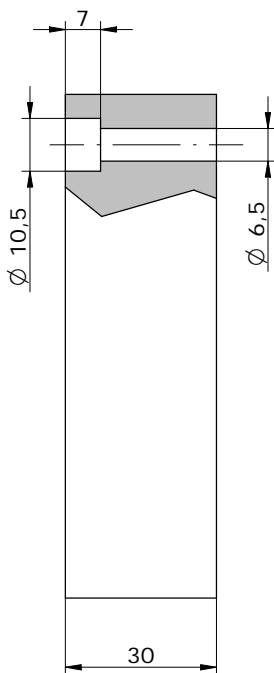
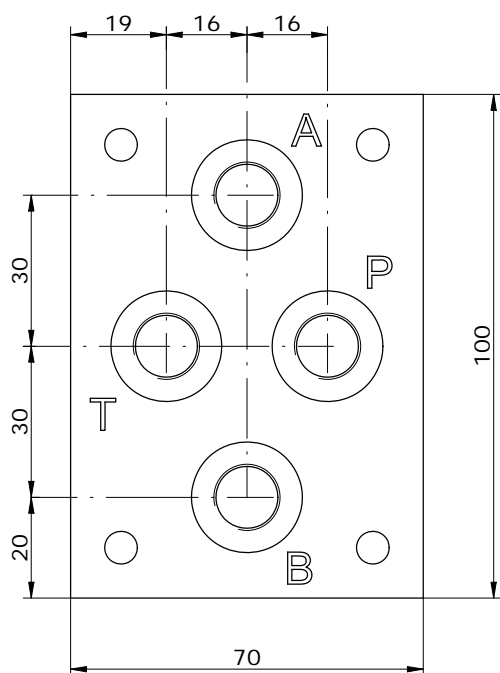
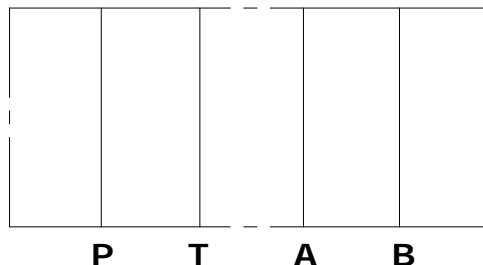

**E\_ 06 - 07 - \_\_\_\_\_**

**S = STEEL**  
**A = ALUMINUM**

**14 = BSP 1/4G**  
**38 = BSP 3/8G**  
**12 = BSP 1/2G**



**BASE SINGOLA CETOP 3 CON UTILIZZI A-B-P-T LATERALI**  
**SUB-PLATE CETOP 3 WITH A-B-P-T PORTS ON SIDE**

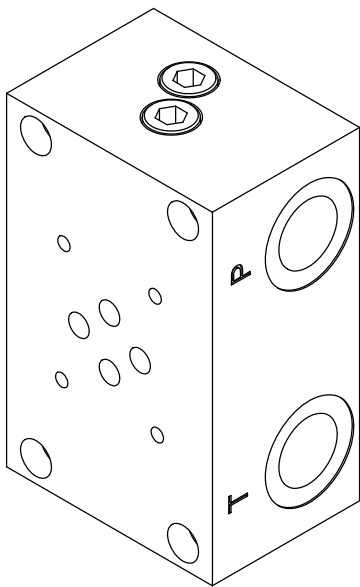

Schema idraulico  
Hydraulic diagram

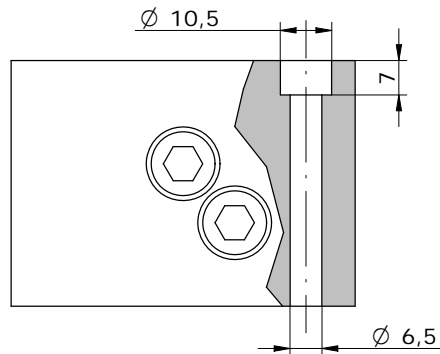
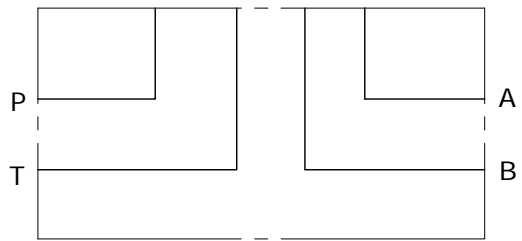

VERSION	R	L	M
E_06-08-14	45	15	27
E_06-08-38	45	15	27
E_06-08-12	50	17	29

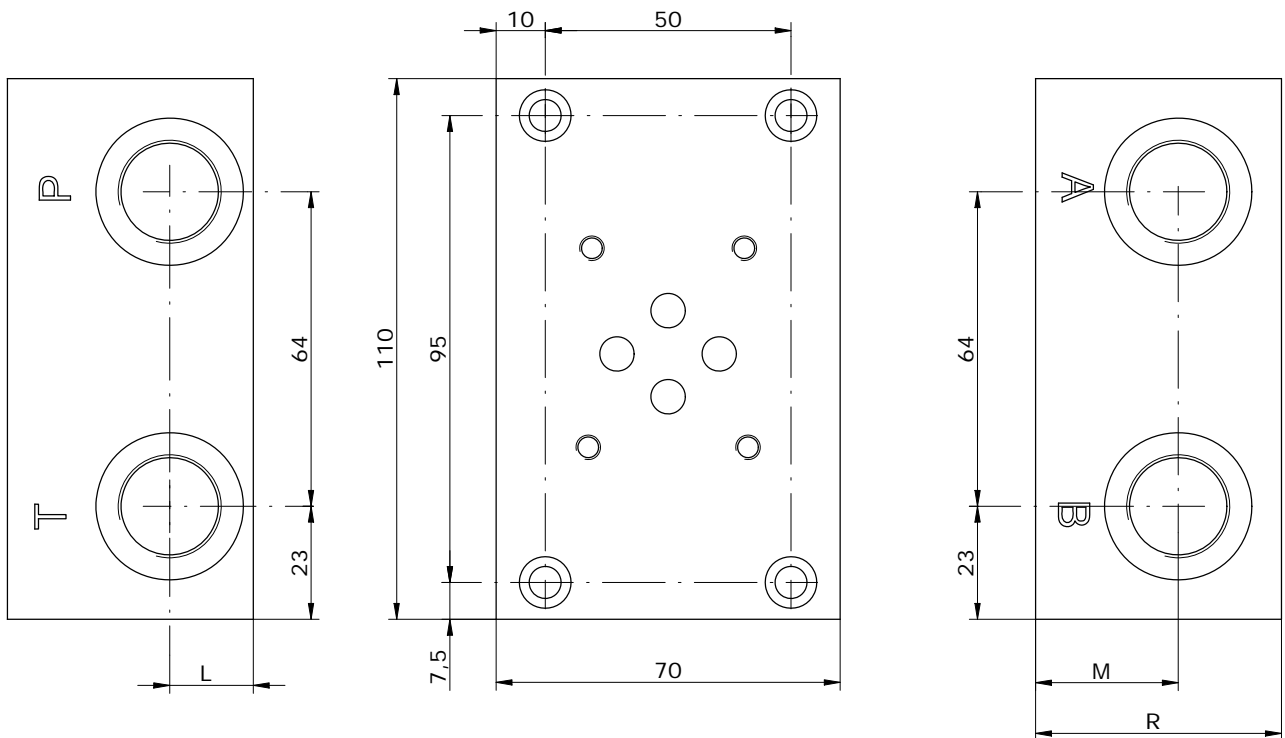

**E\_06 - 08 -**

**S** = STEEL  
**A** = ALUMINUM

**14** = BSP 1/4G  
**38** = BSP 3/8G  
**12** = BSP 1/2G

**BASE SINGOLA CETOP 3 CON UTILIZZI A-B-P-T LATERALI**  
**SUB-PLATE CETOP 3 WITH A-B-P-T PORTS ON SIDE**

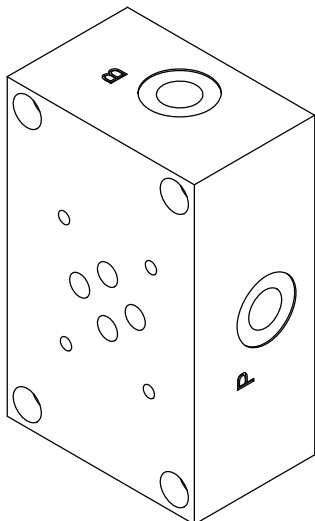

Schema idraulico  
Hydraulic diagram

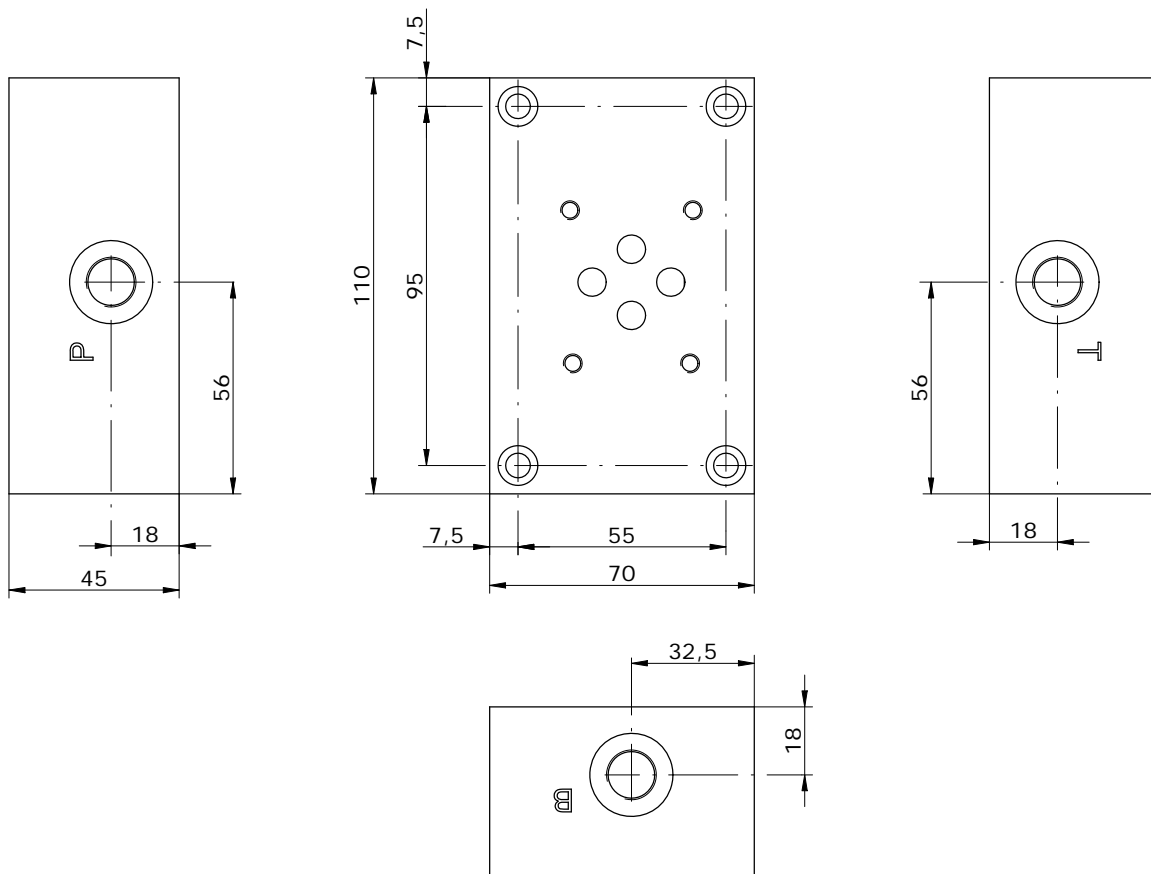
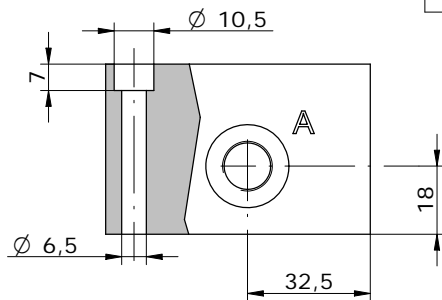
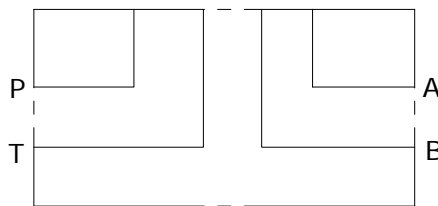

**E\_ 06 - 09 - \_\_\_\_\_**

**S** = STEEL  
**A** = ALUMINUM

**14** = BSP 1/4G  
**38** = BSP 3/8G  
**12** = BSP 1/2G

**BASE SINGOLA CETOP 3 CON UTILIZZI A-B-P-T LAT. P-T POST. 3/8" BSP  
SUB-PLATE CETOP 3 WITH A-B-P-T PORTS ON SIDE P-T BACK 3/8" BSP**

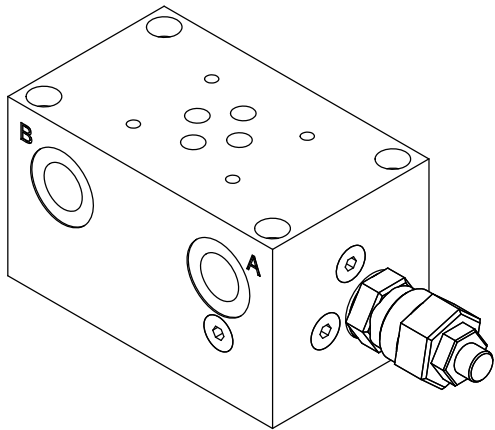

Schema idraulico  
Hydraulic diagram

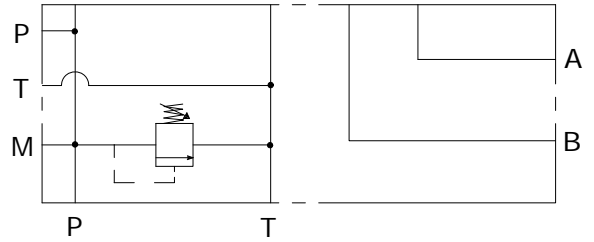

**TIPI DI REGOLAZIONE  
REGULATION TYPE**

	<b>H</b>	VITE CON CHIAVE ESAGONALE (standard) <i>HEXAGONAL HEAD SCREW</i>
	<b>K</b>	POMOLO <i>KNOB</i>
	<b>C</b>	FISSA CON CAPPuccio <i>COVER CAP</i>
	<b>I</b>	INVIOlabILE <i>NON ADJUSTABLE</i>

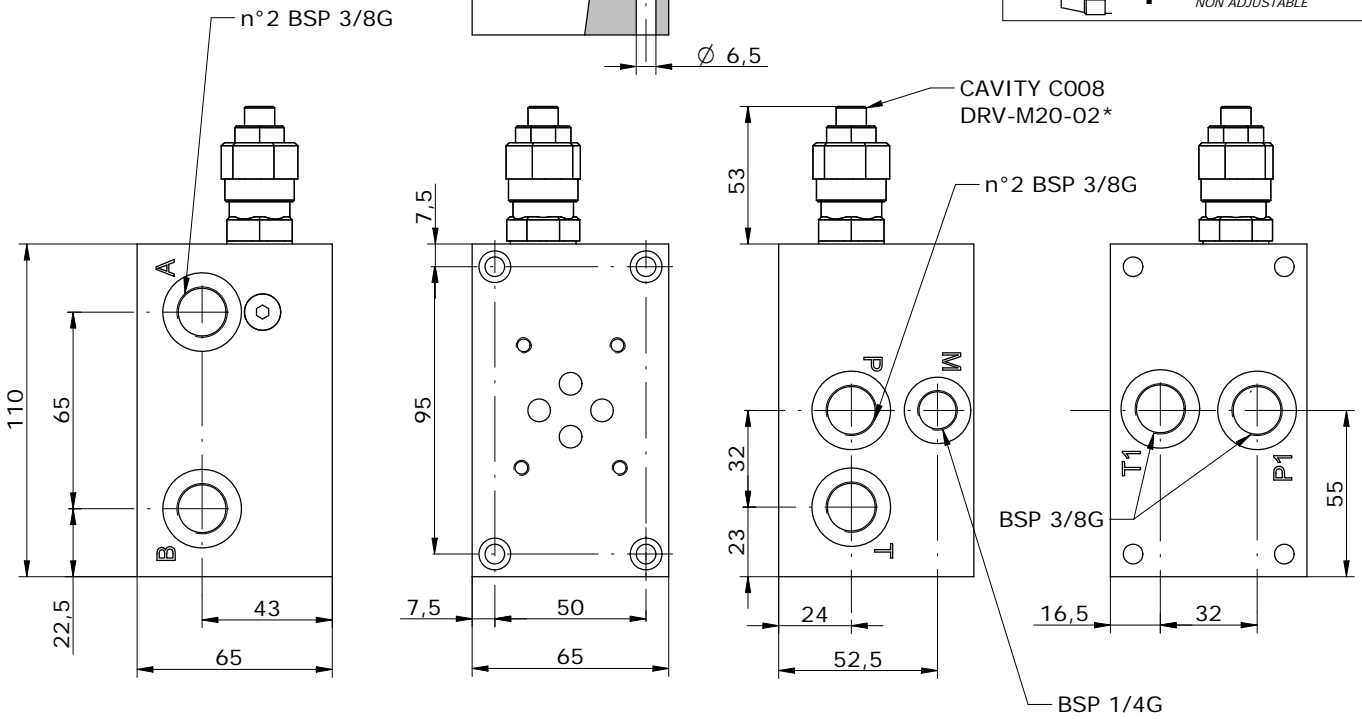
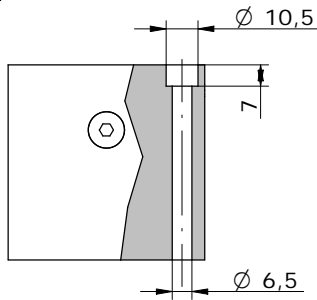

**E\_06 - 10 - 38 - - - - -**

**S** = STEEL  
**A** = ALUMINUM

**0** = WITHOUT RELIEF VALVE  
**1** = WITH RELIEF VALVE  
**2** = RELIEF VALVE READY

**0** = WITHOUT RELIEF VALVE  
**H** = HEXAGONAL HEAD SCREW  
**K** = KNOB  
**C** = COVER CAP  
**I** = NOT ADJUSTABLE

**0** = WITHOUT R.V.  
**1** = 5-50 BAR  
**2** = 20-110 BAR  
**3** = 50-220 BAR  
**4** = 100-350 BAR  
**5** = 100-420 BAR

\*see *CARTDRIGE VALVES* catalog

**BASE SINGOLA CETOP 3 CON UTILIZZI A-B LAT. P-T POST. 1/2" BSP  
SUB-PLATE CETOP 3 WITH A-B PORTS ON SIDE P-T BACK 1/2" BSP**

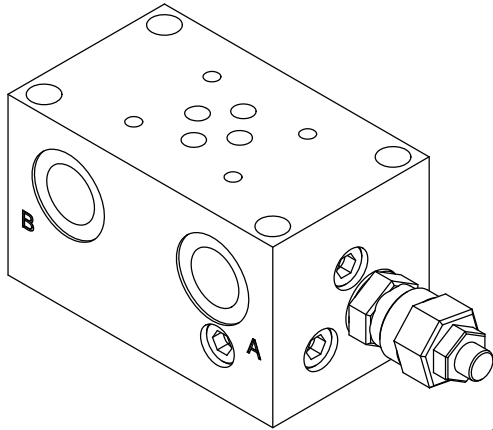

Schema idraulico  
Hydraulic diagram

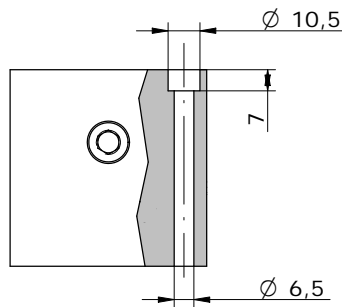
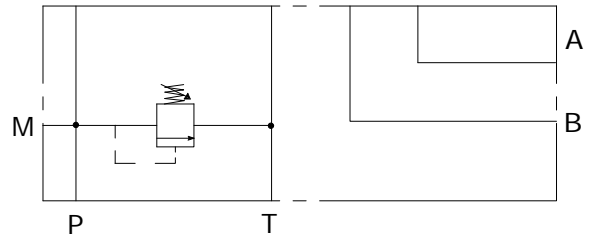

**TIPI DI REGOLAZIONE  
REGULATION TYPE**

	<b>H</b>	VITE CON CHIAVE ESAGONALE (standard) <i>HEXAGONAL HEAD SCREW</i>
	<b>K</b>	POMOLO <i>KNOB</i>
	<b>C</b>	FISSA CON CAPPUCCIO <i>COVER CAP</i>
	<b>I</b>	INVOLABILE <i>NON ADJUSTABLE</i>

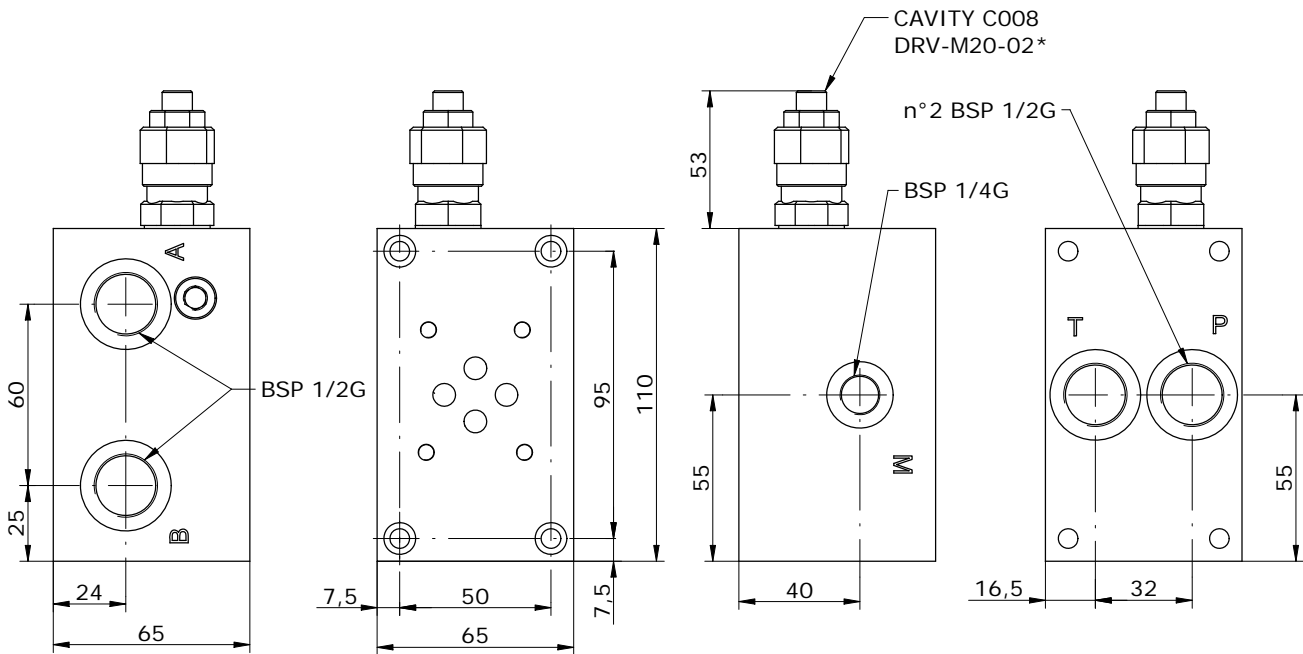

**E\_06 - 10 - 12 - - - -**

**S** = STEEL  
**A** = ALUMINUM

**0** = WITHOUT RELIEF VALVE  
**1** = WITH RELIEF VALVE  
**2** = RELIEF VALVE READY

**OMIT**  
**H** = HEXAGONAL HEAD SCREW  
**K** = KNOB  
**C** = COVER CAP  
**I** = NOT ADJUSTABLE

**0** = WITHOUT R.V.  
**1** = 5-50 BAR  
**2** = 20-110 BAR  
**3** = 50-220 BAR  
**4** = 100-350 BAR  
**5** = 100-420 BAR

\*see *CARTDRIGE VALVES* catalog

WWW.GPA.BY

**BASE SINGOLA CETOP 3 CON UTILIZZI A-B LAT. P-T POST.  
SUB-PLATE CETOP 3 WITH A-B PORTS ON SIDE P-T BACK**

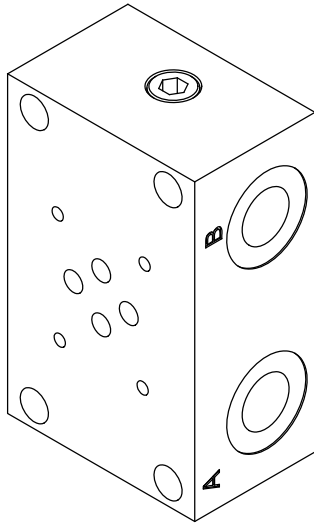

Schema idraulico  
Hydraulic diagram

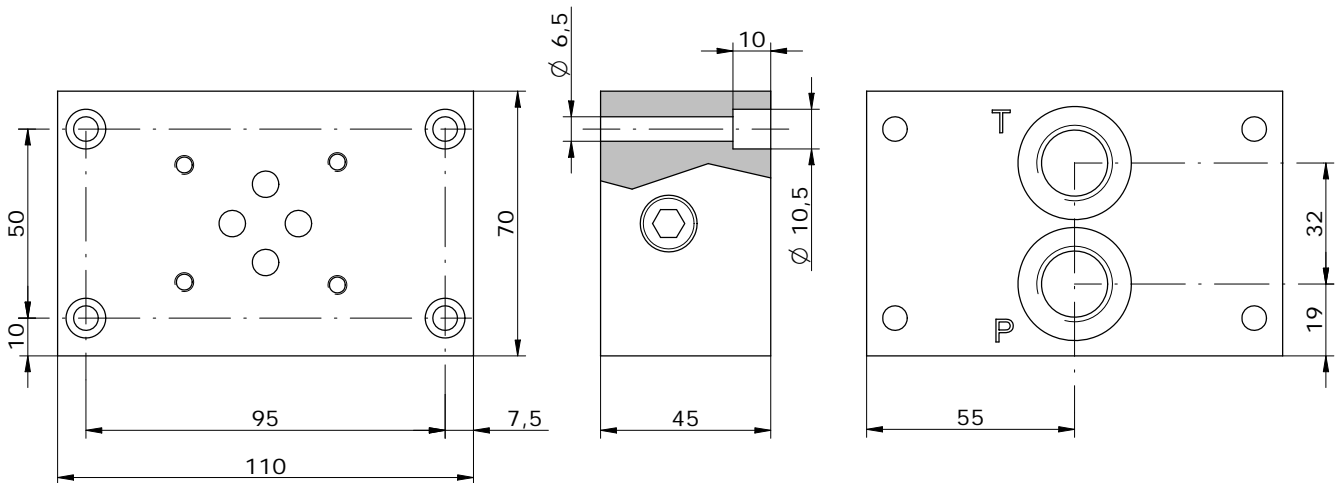
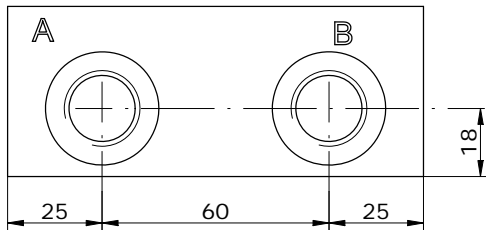
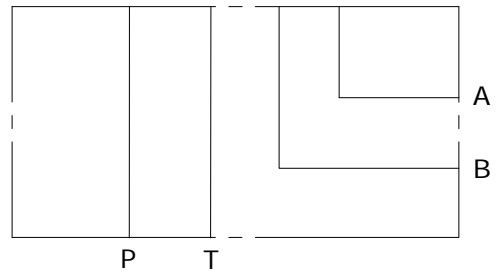

**E\_ 06 - 15 - \_\_\_\_\_**

**S** = STEEL  
**A** = ALUMINUM

**14** = BSP 1/4G  
**38** = BSP 3/8G  
**12** = BSP 1/2G

**BASE SINGOLA CETOP 3 CON UTILIZZI A-B-P-T LAT. P-T POST.**  
**SUB-PLATE CETOP 3 WITH A-B-P-T PORTS ON SIDE P-T BACK**

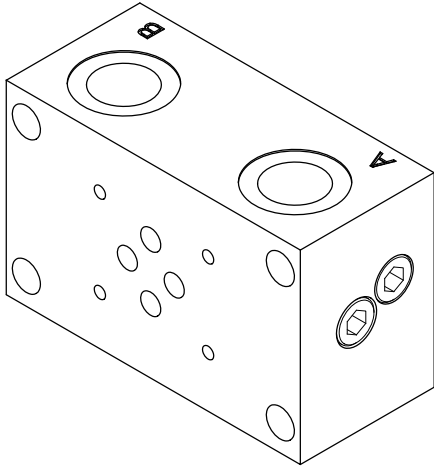

Schema idraulico  
Hydraulic diagram

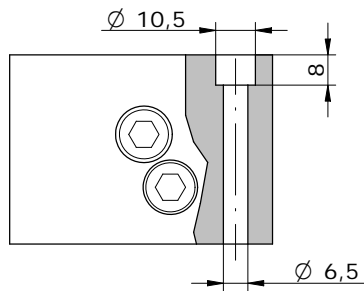
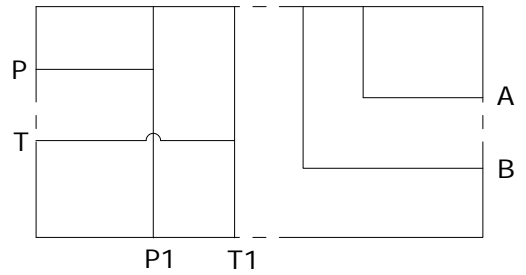

VERSION	R
E_06-16-14	45
E_06-16-38	45
E_06-16-12	50

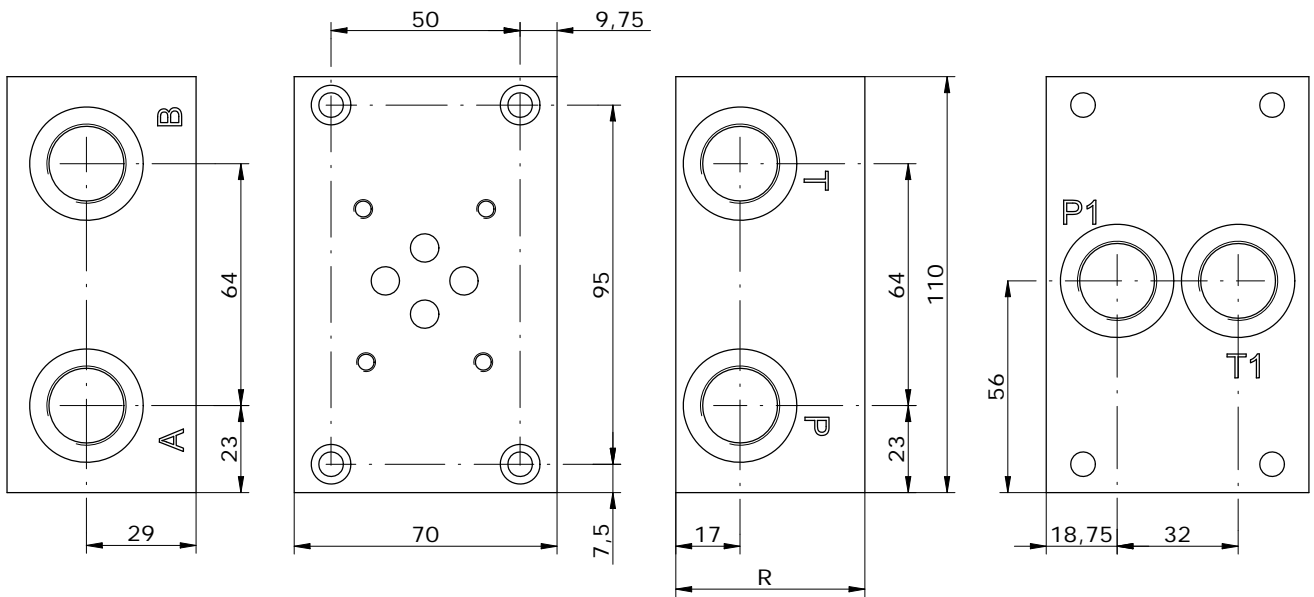

**E\_06 - 16 - \_\_\_\_\_**

**S** = STEEL  
**A** = ALUMINUM

**14** = BSP 1/4G  
**38** = BSP 3/8G  
**12** = BSP 1/2G

**BASE SINGOLA CETOP 3 CON UTILIZZI A-B LAT. P-T POST. BSP3/8"G**  
**SUBPLATE CETOP 3 WITH A-B PORTS ON SIDE P-T BACK BSP3/8"G**



Schema idraulico  
Hydraulic diagram

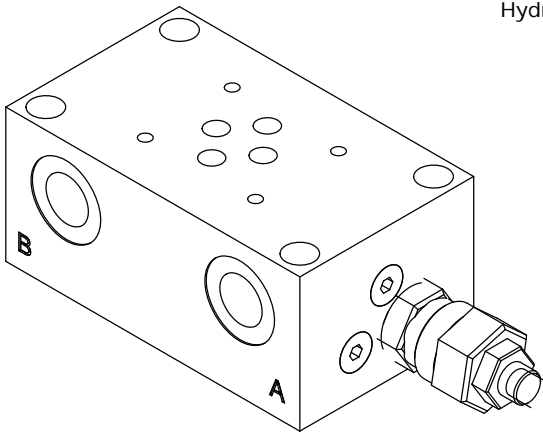
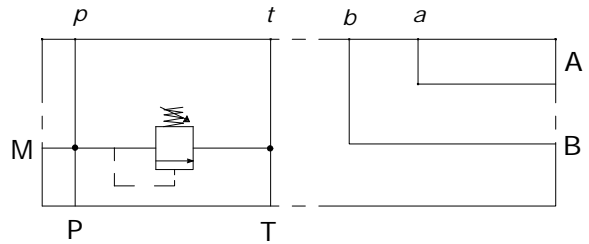

**TIPI DI REGOLAZIONE**  
**REGULATION TYPE**

	<b>H</b> VITE CON CHIAVE ESAGONALE (standard) HEXAGONAL HEAD SCREW
	<b>K</b> POMOLO KNOB
	<b>C</b> FISSA CON CAPPUCCIO COVER CAP
	<b>I</b> INVIOLABILE NON ADJUSTABLE

CAVITY C008  
DRV-M20-02\*

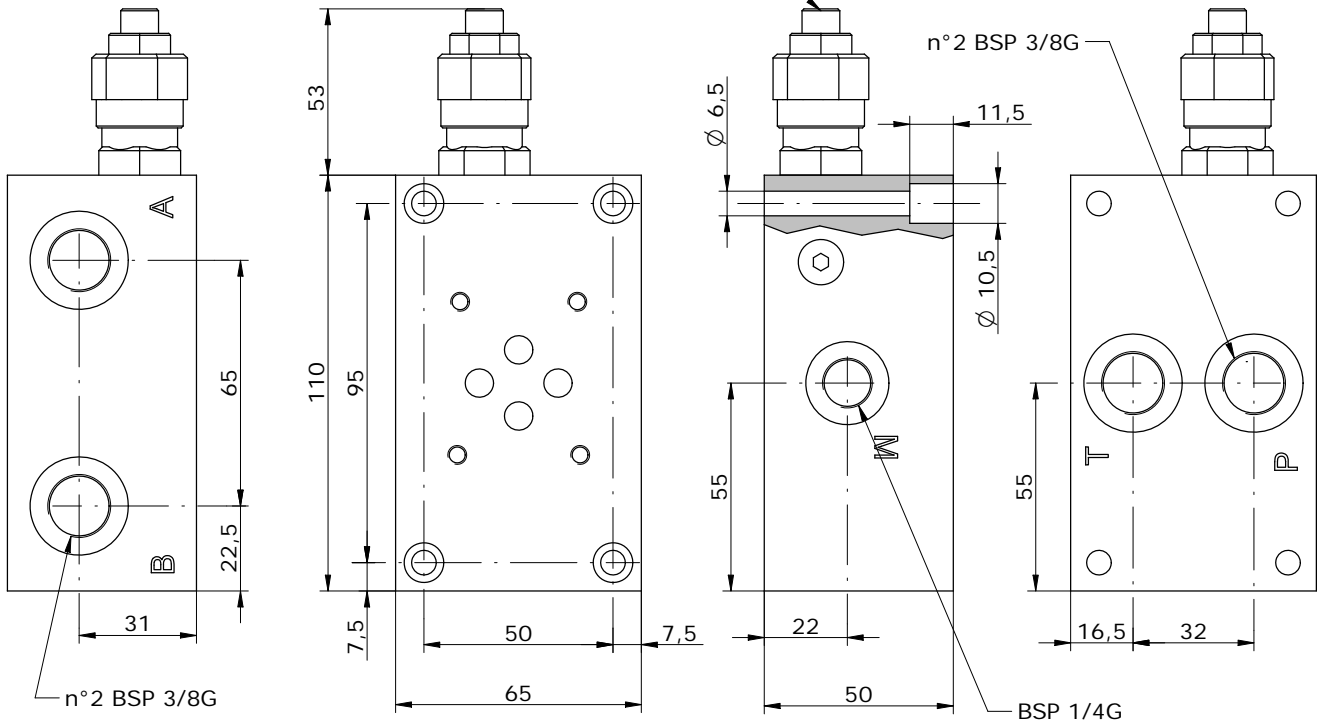

**E\_ 06 - 22 - 38 - - - -**

**S** = STEEL  
**A** = ALUMINUM

**0** = WITHOUT RELIEF VALVE  
**1** = WITH RELIEF VALVE  
**2** = RELIEF VALVE READY

**OMETTERE / OMIT**  
**H** = HEXAGONAL HEAD SCREW  
**K** = KNOB  
**C** = COVER CAP  
**I** = NOT ADJUSTABLE

**0** = WITHOUT R.V.  
**1** = 5-50 BAR  
**2** = 20-110 BAR  
**3** = 50-220 BAR  
**4** = 100-350 BAR  
**5** = 100-420 BAR

\*see **CARTDRIGE VALVES** catalog

WWW.GPA.BY

**BASE SINGOLA CETOP 3 CON UTILIZZI A-B LAT. P-T POST. 3/8" BSP  
SUB-PLATE CETOP 3 WITH A-B PORTS ON SIDE P-T BACK 3/8" BSP**

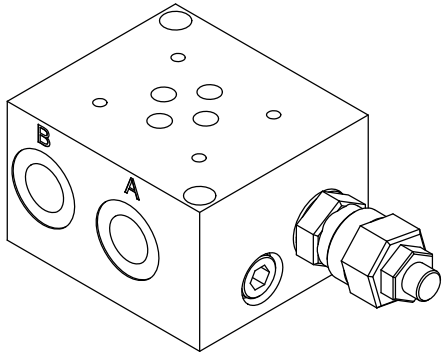

Schema idraulico  
Hydraulic diagram

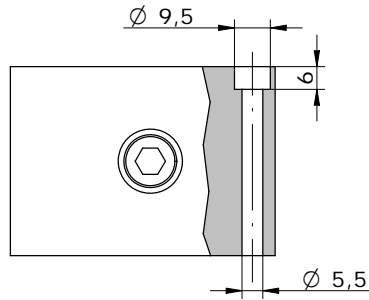
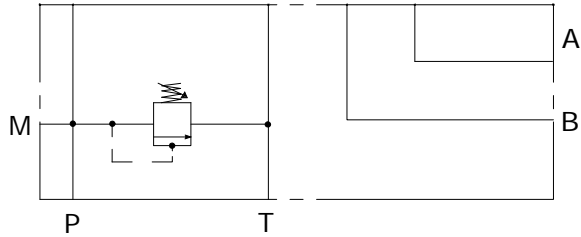

**TIPI DI REGOLAZIONE  
REGULATION TYPE**

	<b>H</b>	VITE CON CHIAVE ESAGONALE (standard) HEXAGONAL HEAD SCREW
	<b>K</b>	POMOLO KNOB
	<b>C</b>	FISSA CON CAPPUCCIO COVER CAP
	<b>I</b>	INVOLABILE NON ADJUSTABLE

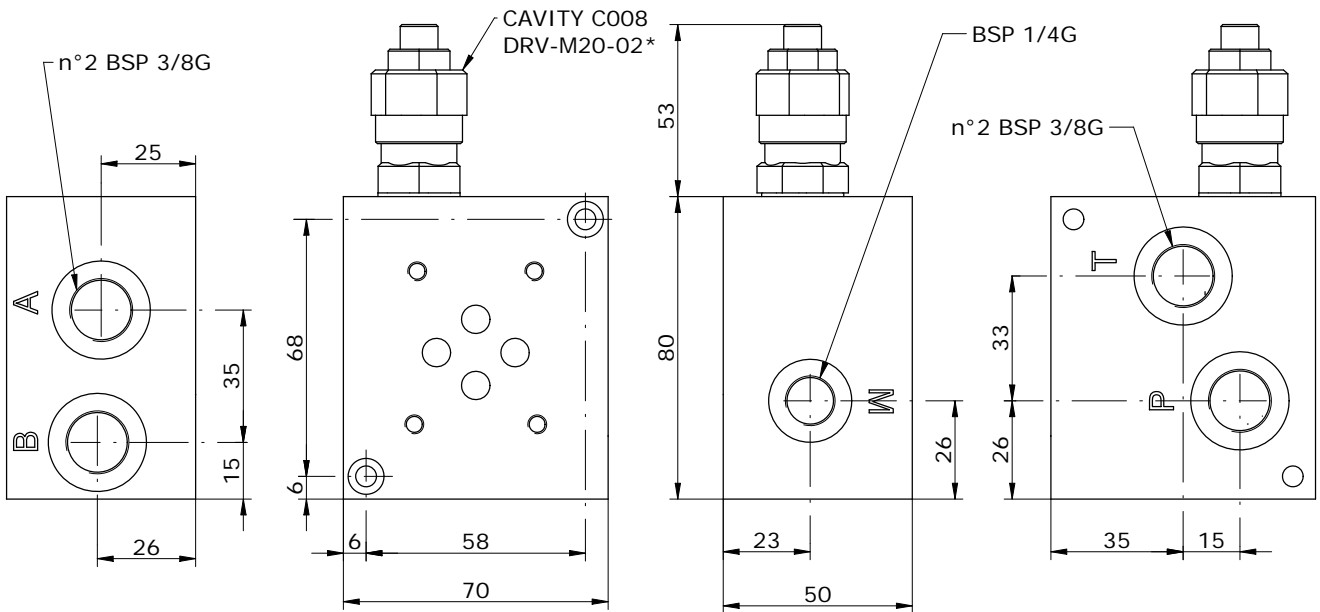

**E\_ 06 - 33 - 38 - - - -**

**S** = STEEL  
**A** = ALUMINUM

**0** = WITHOUT RELIEF VALVE  
**1** = WITH RELIEF VALVE  
**2** = RELIEF VALVE READY

**OMETTERE**  
**H** = HEXAGONAL HEAD SCREW  
**K** = KNOB  
**C** = COVER CAP  
**I** = NOT ADJUSTABLE

**0** = WITHOUT R.V.  
**1** = 5-50 BAR  
**2** = 20-110 BAR  
**3** = 50-220 BAR  
**4** = 100-350 BAR  
**5** = 100-420 BAR

\*see *CARTDRIGE VALVES* catalog

WWW.GPA.BY



**BASE SINGOLA CETOP 3 CON UTILIZZI A-B-P-T LATERALI BSP 3/8"**  
**SUB-PLATE CETOP 3 WITH A-B-P-T PORTS ON SIDE BSP 3/8"**

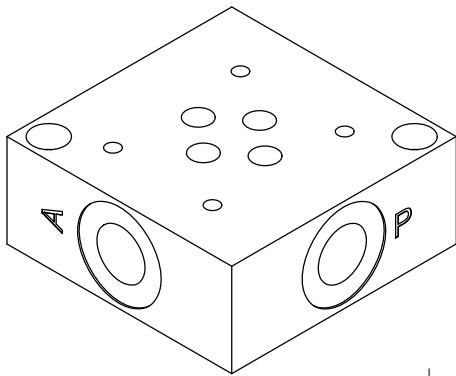

Schema idraulico  
Hydraulic diagram

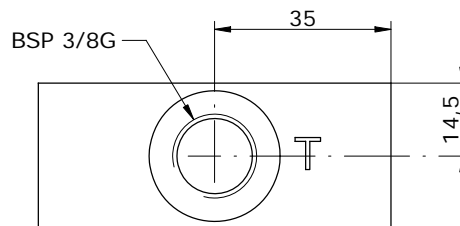
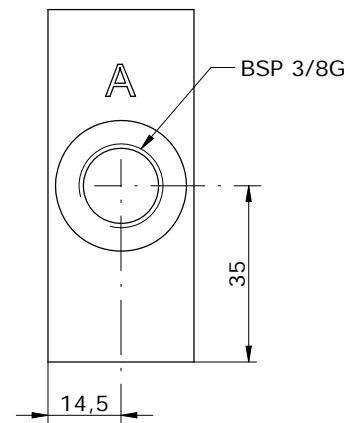
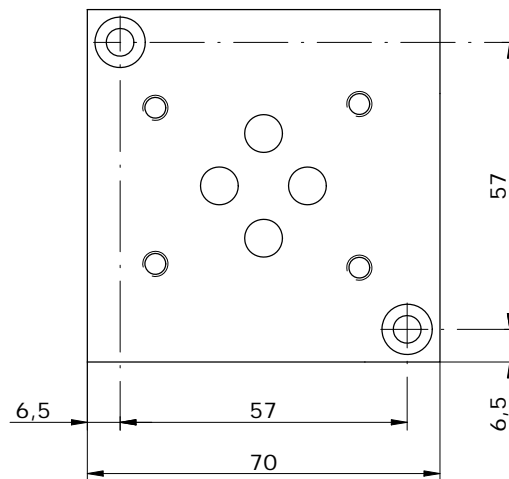
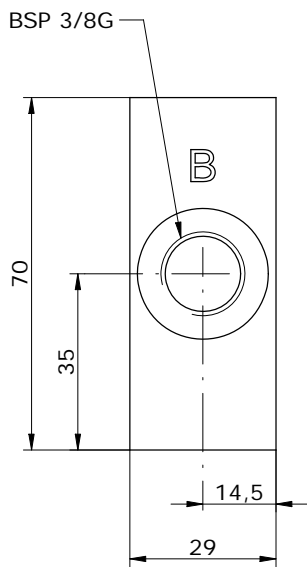
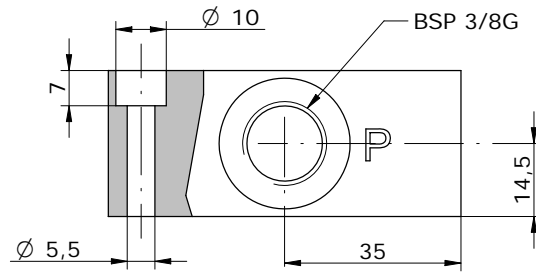
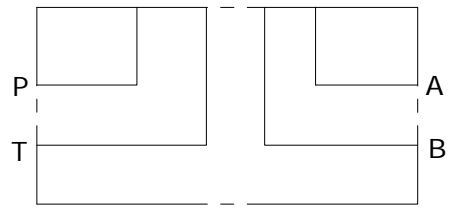

**E\_ - 06 - 40 - 38**

**S** = STEEL  
**A** = ALUMINUM

**BASE SINGOLA CETOP 3 CON UTILIZZI A-B-P-T LATERALI BSP 3/8"**  
**SUB-PLATE CETOP 3 WITH A-B-P-T PORTS ON SIDE BSP 3/8"**

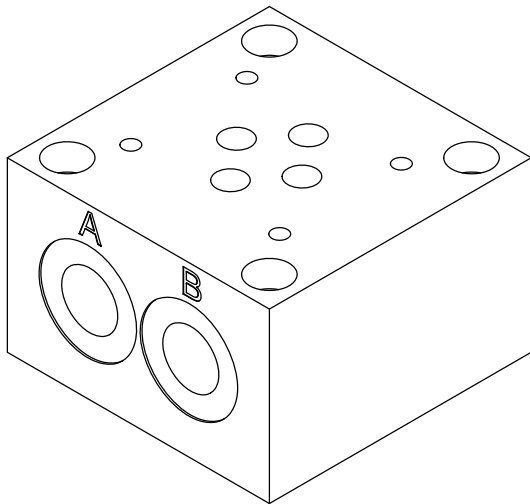

Schema idraulico  
Hydraulic diagram

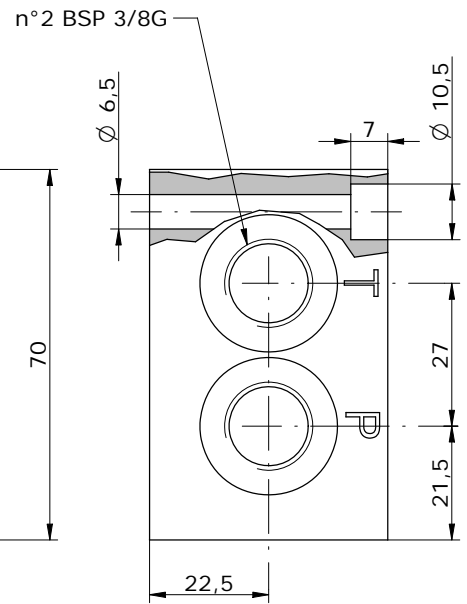
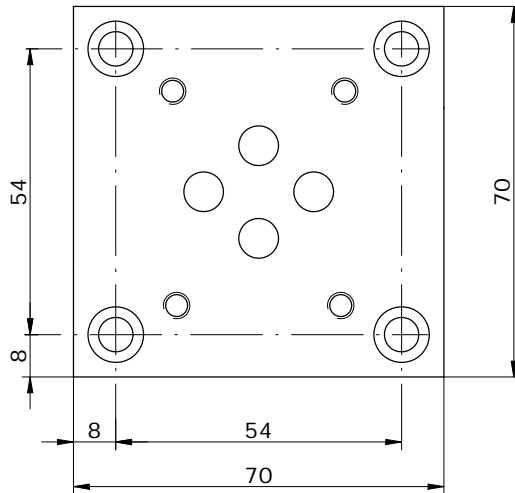
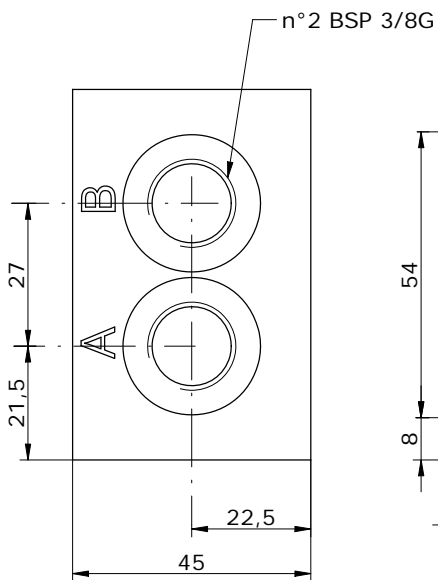
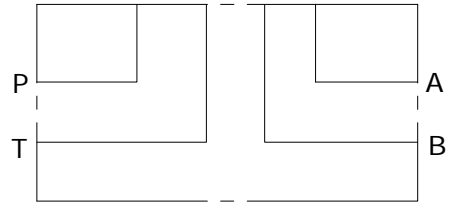

**E\_ - 06 - 41 - 38**

**A = ALUMINUM**  
**S = STEEL**

**PANNELLO MODULARE A-B LATERALE 3/8" P-T 1/2"**  
**MODULAR PLATE A-B ON SIDE 3/8" P-T 1/2"**

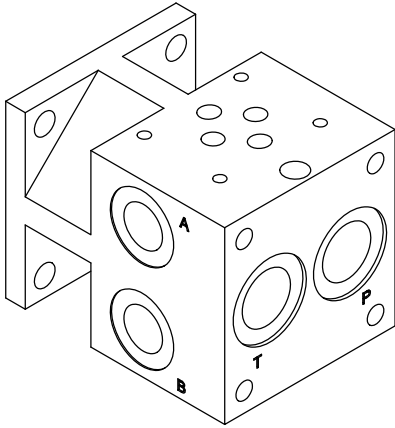

Schema idraulico  
Hydraulic diagram

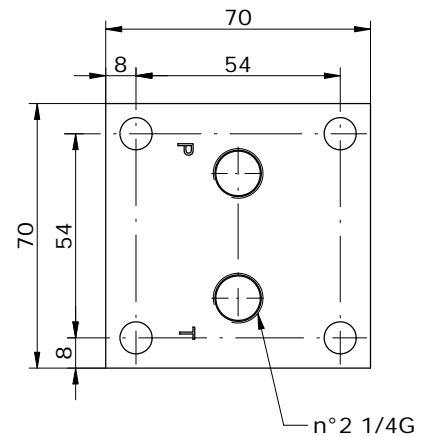
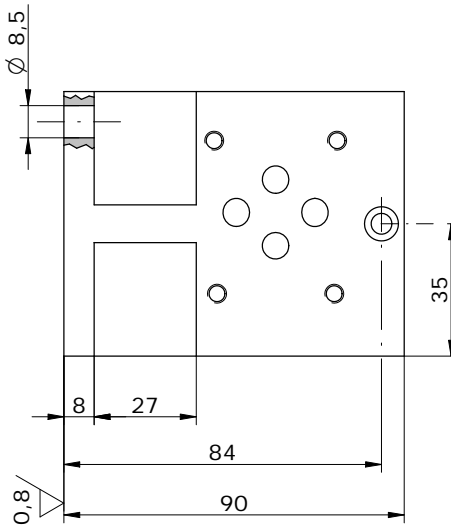
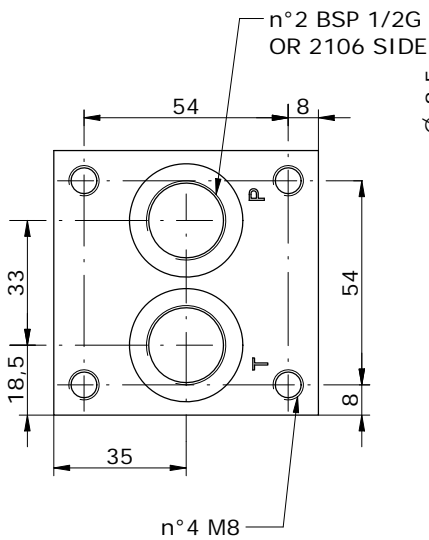
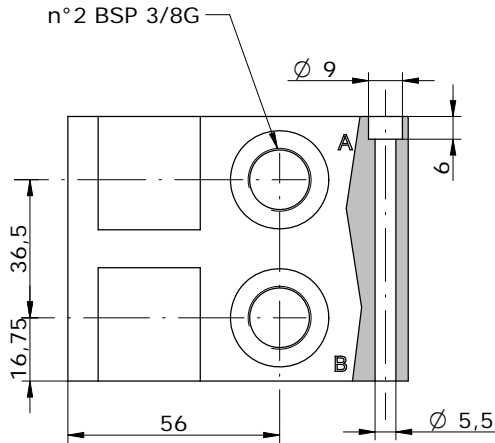
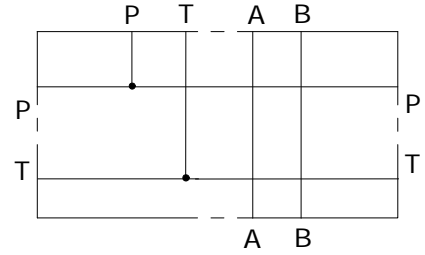

**AVAILABLE FOR:**

E\_06-12

E\_06-14

E\_06-21

**E\_06 - 27 - 38**

**S** = STEEL  
**A** = ALUMINUM

**ELEMENTO AGGIUNTIVO CETOP 3 PER RIDUTTRICE CETOP - P IN B -  
MODULAR PLATE NG6 FOR REDUCING VALVE WITH P IN B**

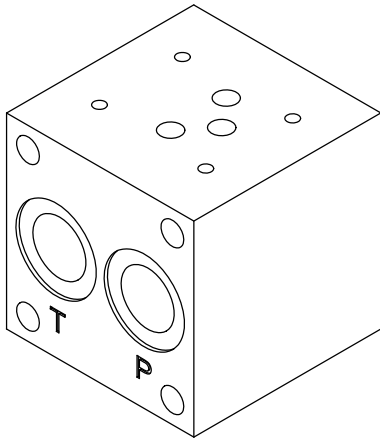

Schema idraulico  
Hydraulic diagram

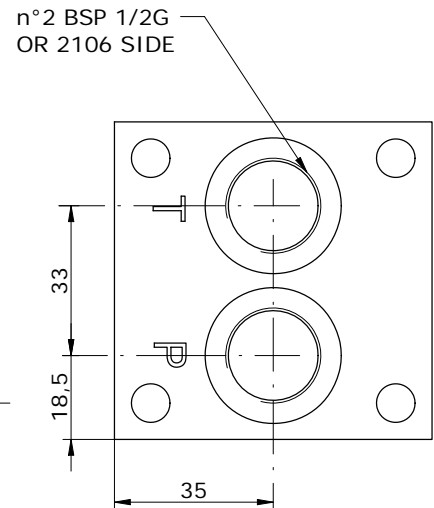
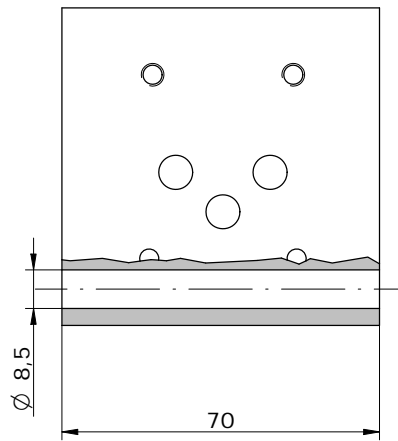
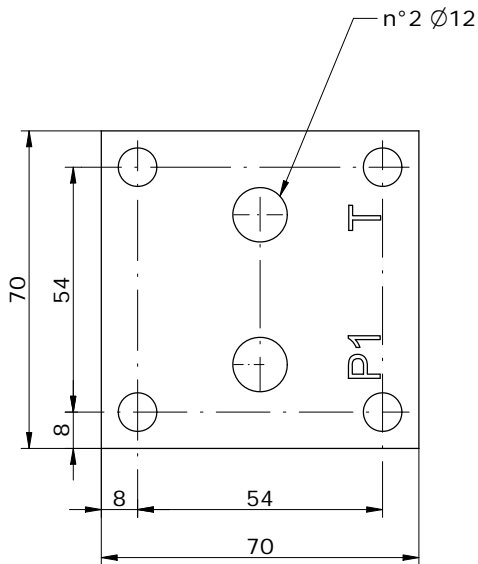
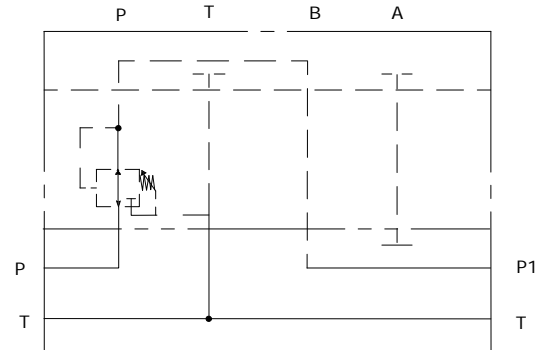

**AVAILABLE FOR:**

- E\_ 06-12
- E\_ 06-14
- E\_ 06-21
- E\_ 06-39

**E\_ 06 - 29**

**S** = STEEL  
**A** = ALUMINUM

**ELEMENTO VENTING O VALVOLA DI MASSIMA**  
**VENTING ELEMENT OR RELIEF VALVE**

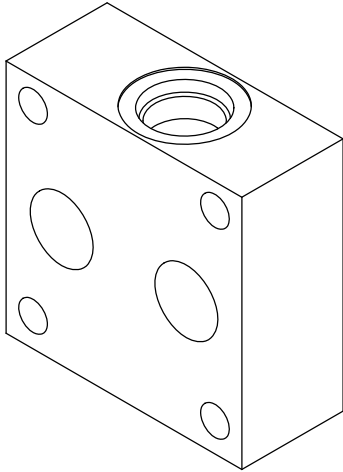

Schema idraulico  
Hydraulic diagram

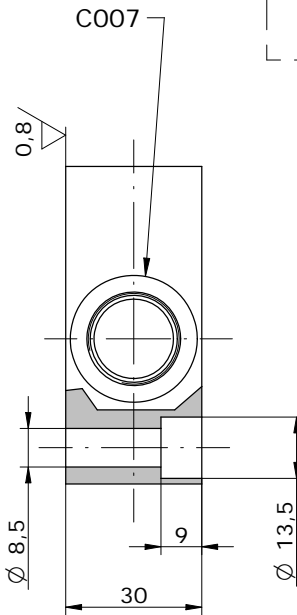
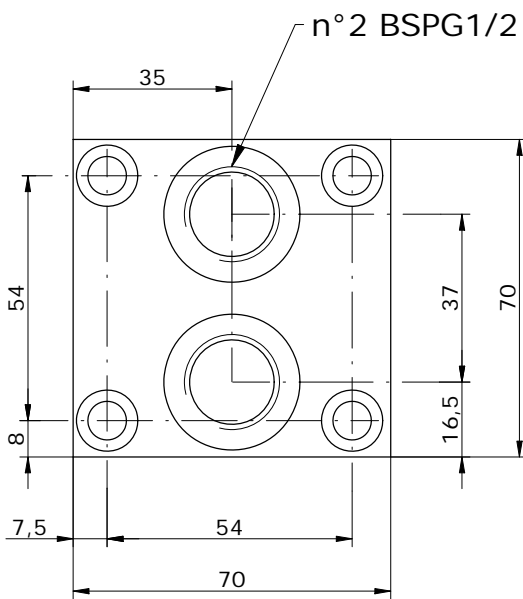
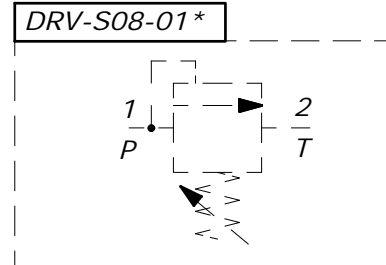
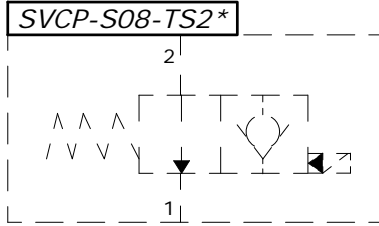

**EXAMPLE OF APPLICATION**

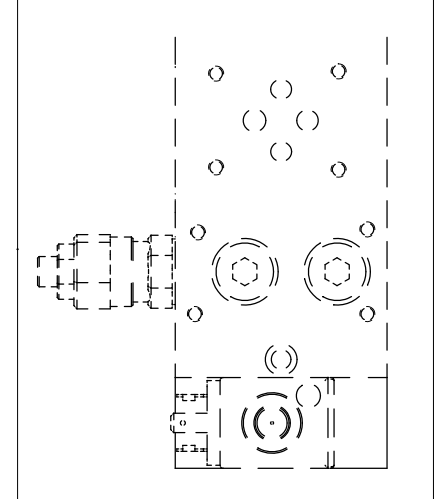

**TIPI DI REGOLAZIONE PER V. MAX**  
**REGULATION TYPE FOR RELIEF VALVE**

	<b>H</b> VITE CON CHIAVE ESAGONALE (standard) HEXAGONAL HEAD SCREW
	<b>K</b> POMOLO KNOB
	<b>C</b> FISSA CON CAPPuccio COVER CAP
	<b>I</b> INVOLABILE NON ADJUSTABLE

Valve to be sold separately

**AVAILABLE FOR:**  
**ES06-12**  
**ES06-14**  
**ES06-21**

**E\_06 - 17 - 12 -**

**S** = STEEL  
**A** = ALUMINUM

**0** = WITHOUT VALVE  
**1** = WITH VENTING VALVE  
**2** = WITH RELIEF VALVE  
**3** = VALVE READY

**000** = WITHOUT V.V.  
**TS2** = NORMALLY OPEN  
**DRV** = RELIEF VALVE

**SEALS**  
**N** = BUNA  
**V** = VITON

**0** = WITHOUT R.V.  
**1** = 0-90 BAR  
**2** = 50-220 BAR  
**3** = 100-250 BAR  
**4** = 150-350 BAR

**VENTING VALVE**  
**0** = NO MANUAL OVERRIDE  
**3** = PUSH PIN  
**4** = PUSH BOTTON  
**5** = HEX. ALLEN

**RELIEF VALVE**  
**0** = WITHOUT R.V.  
**H** = HEX. HEAD SCREW  
**K** = KNOB  
**C** = COVER CAP  
**I** = NOT ADJUSTABLE

**CONNECTOR TYPE**  
**0** = WITHOUT COIL  
**C** = CAVI / LEADS  
**D** = DIN 43650  
**G** = DEUTSCH DT04-2P  
**A** = AMP JUNIOR

**TENSIONE / VOLTAGE**  
**000** = WITHOUT COIL  
**D12** = 12 VDC  
**D24** = 24 VDC  
**220** = 220 RAC

\*see **CARTDRIGE VALVES** catalog

WWW.GPA.BY

**MONOBLOCCO A-B LATERALI 3/8" P-T 1/2" BSP**  
**MONOBLOCK A-B ON SIDE 3/8" P-T 1/2" BSP**

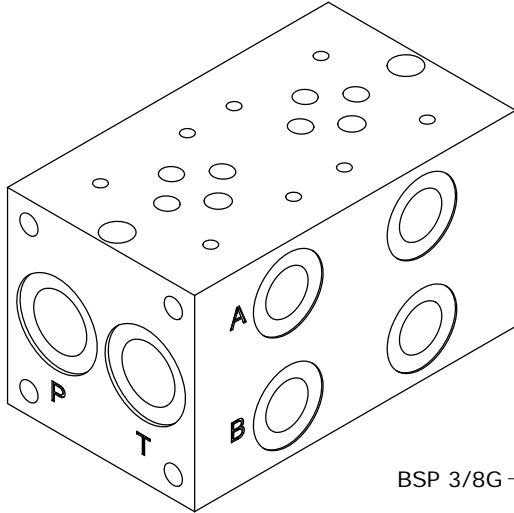

Schema idraulico  
Hydraulic diagram

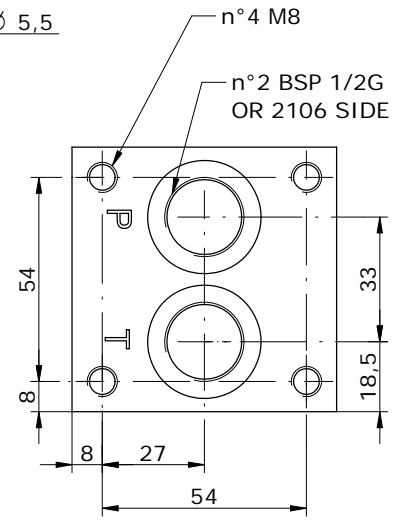
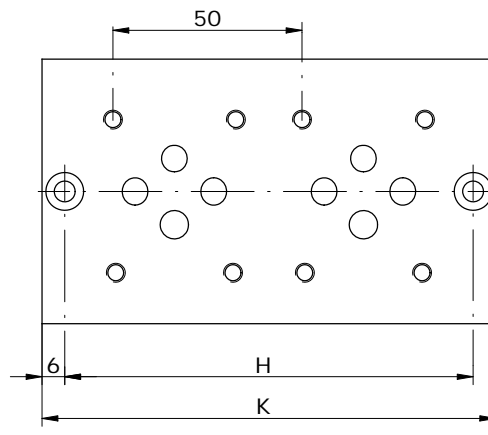
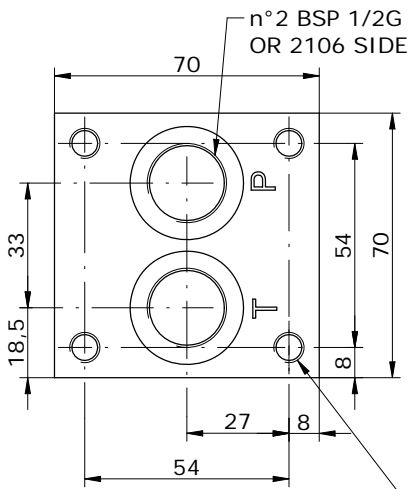
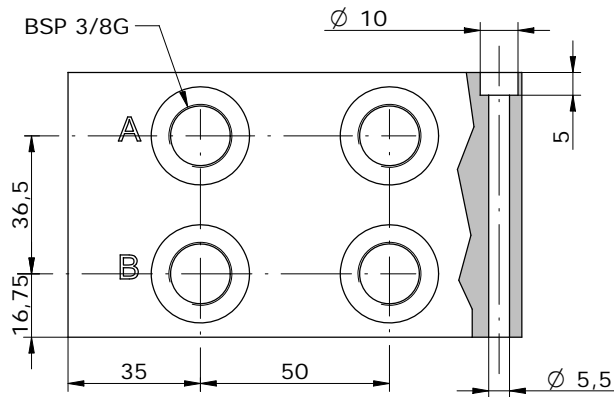
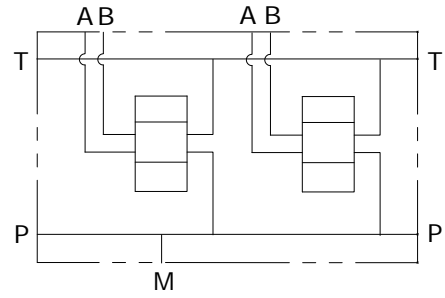

POS.	01	02	03	04	05	06	07	08	09	10
H	58	108	158	208	258	308	358	408	458	508
K	70	120	170	220	270	320	370	420	470	520

**E\_ 06 - 12 - 38 -**

**S = STEEL**  
**A = ALUMINUM**

MOUNTING POSITIONS: 01 ÷ 10

**ELEMENTO AGGIUNTIVO VENTING PER E\_06-21**  
**VENTING ELEMENT FOR E\_06-21**

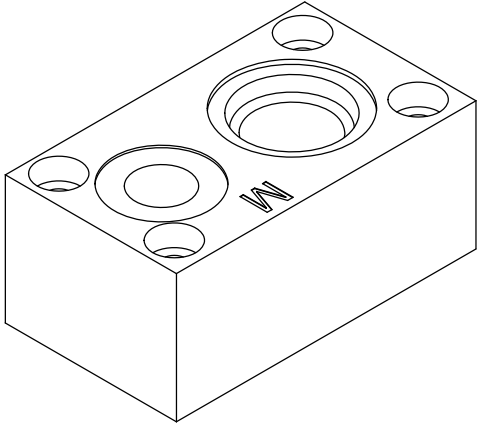

Schema idraulico  
Hydraulic diagram

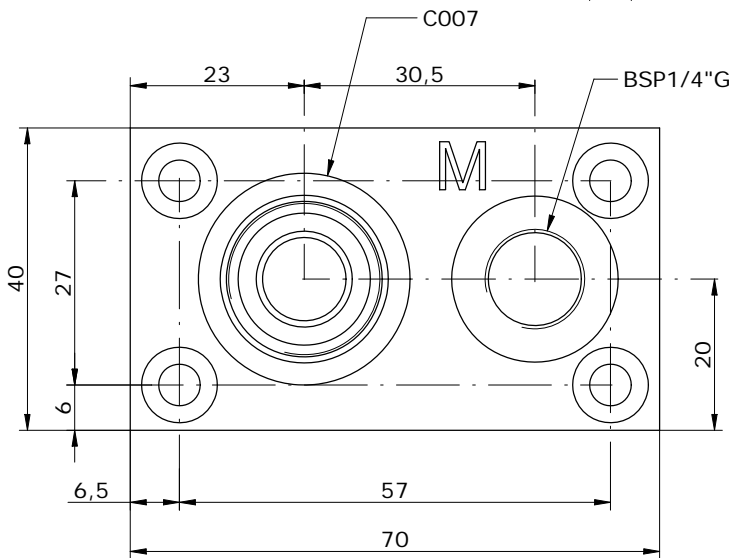
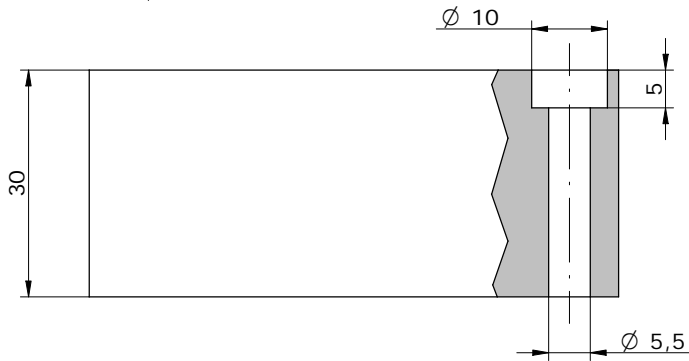
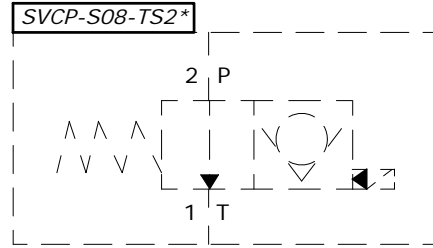

**EXAMPLE OF APPLICATION**

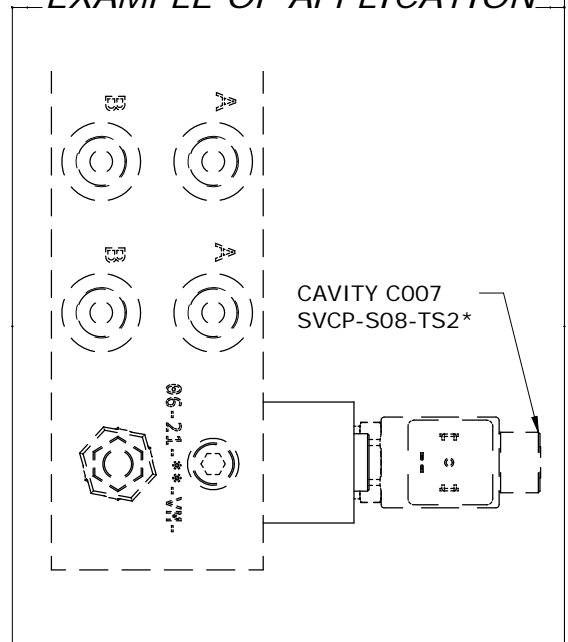

Venting valve to be sold separately

**AVAILABLE FOR:**  
**E\_06-21**

**E\_06 - 24 - - - - -**

**S** = STEEL  
**A** = ALUMINUM

**0** = WITHOUT VENTING VALVE  
**1** = WITH VENTING VALVE  
**2** = VENTING VALVE READY

VENTING VALVE

**000** = WITHOUT V.V.  
**TS2** = NORMALLY OPEN

SEALS

**N** = BUNA  
**V** = VITON

VENTING VALVE

**0** = NO MANUAL OVERRIDE  
**3** = PUSH PIN  
**4** = PUSH BOTTON  
**5** = HEX. ALLEN

CONNECTOR TYPE

**0** = WITHOUT COIL  
**C** = CAVI / LEADS  
**D** = DIN 43650  
**G** = DEUTSCH DT04-2P  
**A** = AMP JUNIOR

TENSIONE / VOLTAGE

**000** = WITHOUT COIL  
**D12** = 12 VDC  
**D24** = 24 VDC  
**220** = 220 RAC

\*see **CARTDRIGE VALVES** catalog

WWW.GPA.BY

**MONOBLOCCO A-B LATERALI 3/8" P-T 1/2" BSP CON VALVOLA EL. OPZIONALE**  
**MONOBLOCK A-B ON SIDE 3/8" P-T 1/2" BSP WITH OPTIONAL VENTING VALVE**

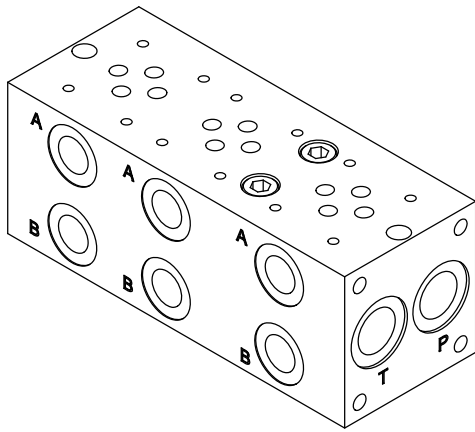

Schema idraulico  
Hydraulic diagram

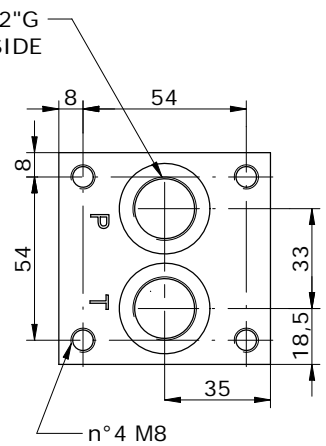
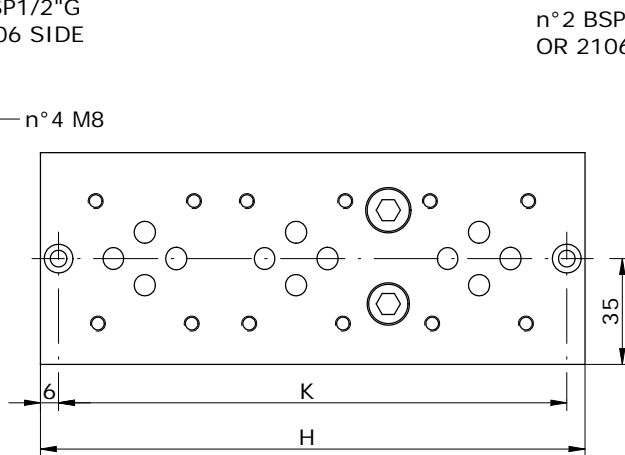
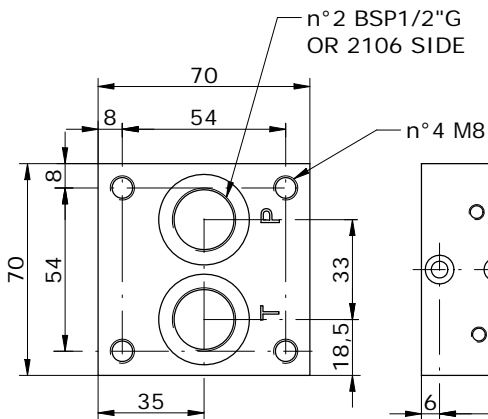
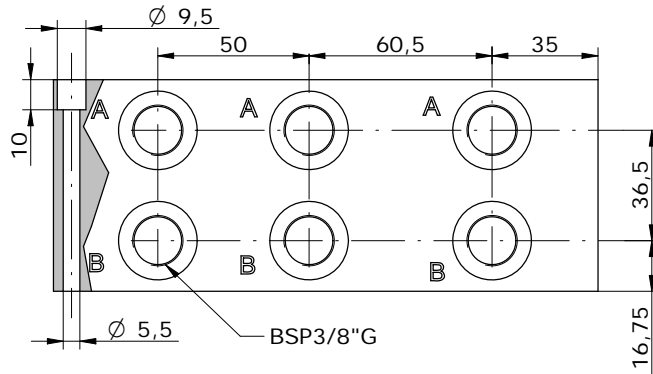
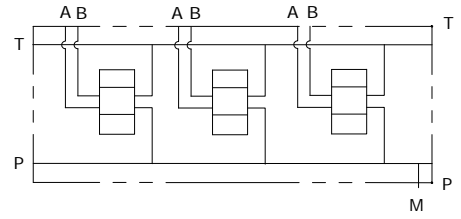

**E\_06 - 14 - 38 - \_\_\_ - 0**

POS.	01	02	03	04	05	06	07	08	09	10
H	90	130	180	230	280	330	380	430	480	530
K	78	118	168	218	268	318	368	418	468	518



**MONOBLOCCO A-B LATERALI 3/8" P-T 1/2" BSP CON VALVOLA EL. OPZIONALE**  
**MONOBLOCK A-B ON SIDE 3/8" P-T 1/2" BSP WITH OPTIONAL VENTING VALVE**



**E\_06 - 14 - 38 - \_\_\_ - 1**

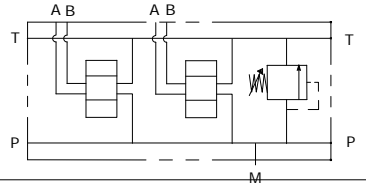
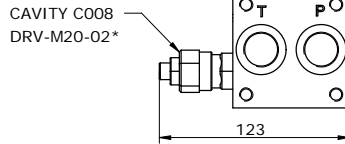
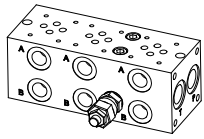

**E\_06 - 14 - 38 - \_\_\_ - 2**

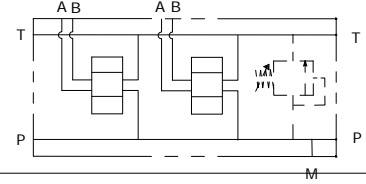
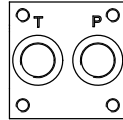
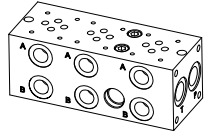

**E\_06 - 14 - 38 - \_\_\_ - 3**

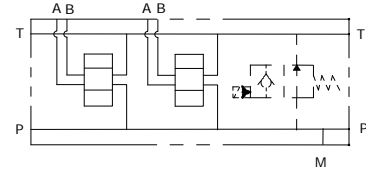
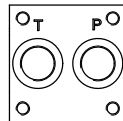
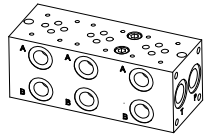

**E\_06 - 14 - 38 - \_\_\_ - 4**

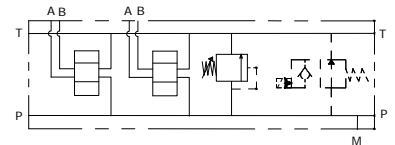
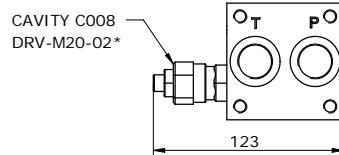
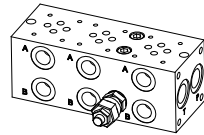

**E\_06 - 14 - 38 - \_\_\_ - 5**

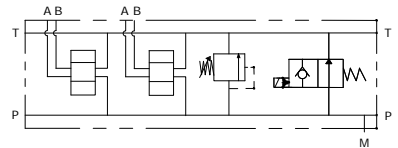
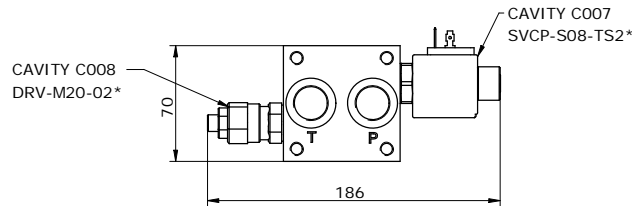
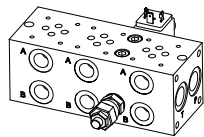

**E\_06 - 14 - 38 - \_\_\_ - 6**

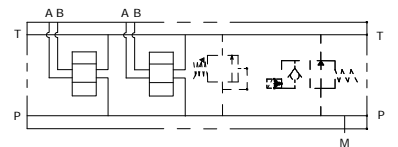
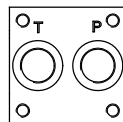
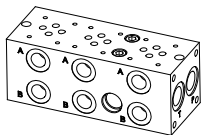

**E\_06 - 14 - 38 - \_\_\_\_\_**

**S** = STEEL  
**A** = ALUMINUM

MOUNTING POSITIONS: 01-10

- 0 = WITHOUT RELIEF VALVE
- 1 = WITH RELIEF VALVE
- 2 = RELIEF VALVE READY
- 3 = VENTING VALVE READY
- 4 = WITH R.V. AND V.V. READY
- 5 = WITH R.V. AND V.V
- 6 = V.V. READY AND R.V. READY

- 0 = WITHOUT R.V.
- 1 = 5-50 BAR
- 2 = 20-110 BAR
- 3 = 50-220 BAR
- 4 = 100-350 BAR
- 5 = 100-420 BAR

- 0 = WITHOUT RELIEF VALVE
- H = HEX. HEAD SCREW
- K = KNOB
- C = COVER CAP
- I = NOT ADJUSTABLE



**SEALS**  
**N** = BUNA  
**V** = VITON

**VENTING VALVE**  
**000** = WITHOUT V.V.  
**TS2** = NORMALLY OPEN

**VENTING VALVE**  
**0** = NO MANUAL OVERRIDE  
**3** = PUSH PIN  
**4** = PUSH BOTTON  
**5** = HEX. ALLEN

**CONNECTOR TYPE**  
**0** = WITHOUT COIL  
**C** = CAVI / LEADS  
**D** = DIN 43650  
**G** = DEUTSCH DT04-2P  
**A** = AMP JUNIOR

**TENSIONE / VOLTAGE**  
**000** = WITHOUT COIL  
**D12** = 12 VDC  
**D24** = 24 VDC  
**220** = 220 RAC

\*see **CARTDRIGE VALVES** catalog

WWW.GPA.BY

**MONOBLOCCO CETOP 3 CON UTILIZZI A-B LAT 3/8" BSP . P-T POST 1/2" BSP CON VALVOLA ELETTRICA OPZIONALE**  
**MONOBLOCK CETOP 3 WITH A-B PORTS ON SIDE 3/8" BSP, P-T BACK 1/2" BSP WITH OPTIONAL VENTING VALVE**

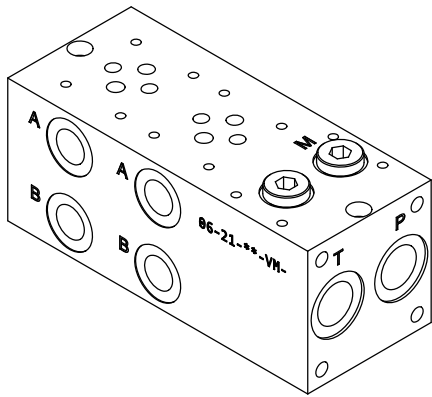

Schema idraulico  
Hydraulic diagram

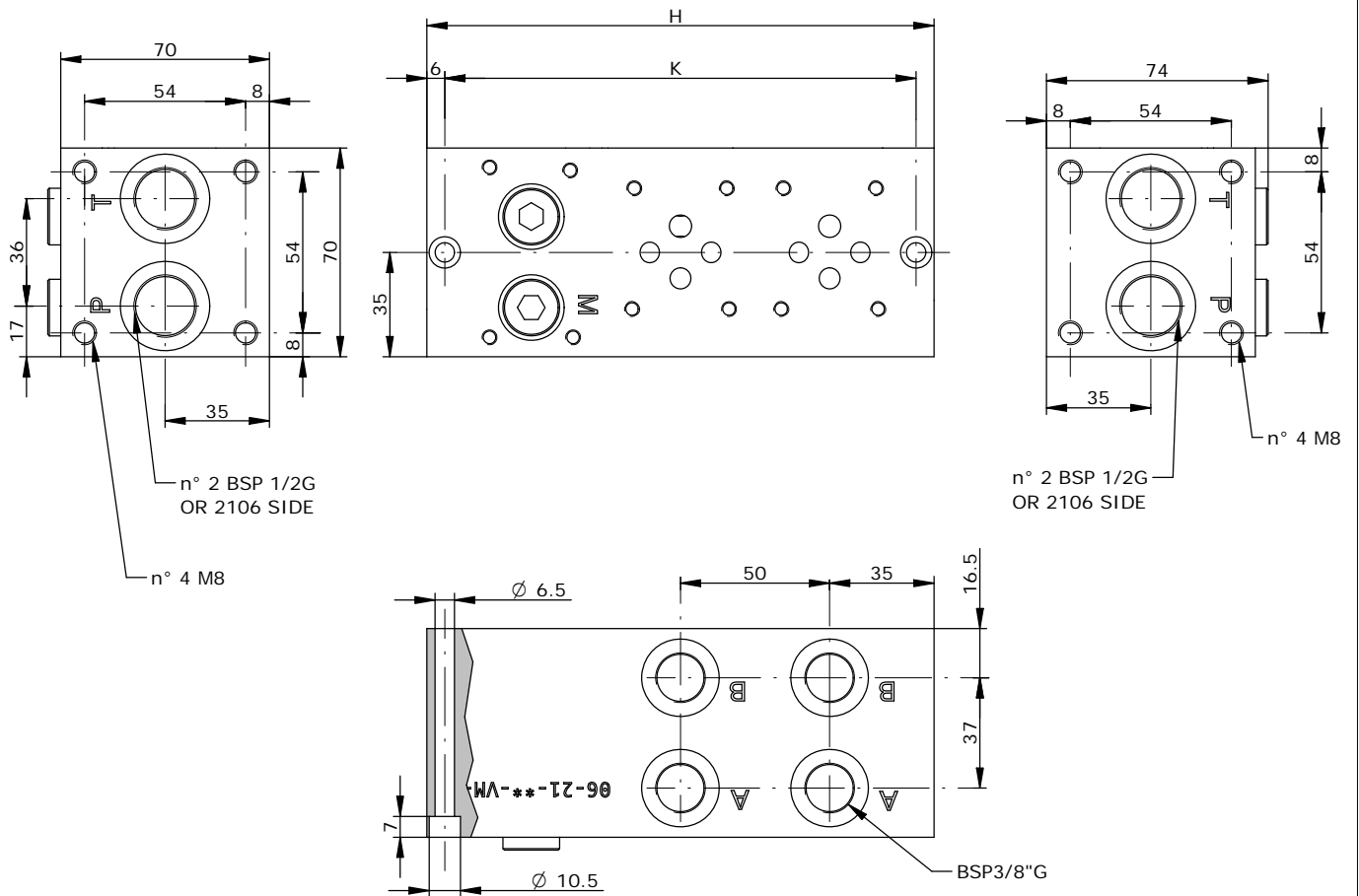
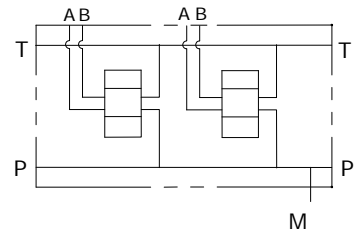

**E\_06 - 21 - 38 - \_\_ - 0**

POS.	01	02	03	04	05	06	07	08	09	10
H	120	170	220	270	320	370	420	470	520	570
K	108	158	208	258	308	358	408	458	508	558

**MONOBLOCCO CETOP 3 CON UTILIZZI A-B LAT 3/8" BSP . P-T POST 1/2" BSP CON VALVOLA ELETTRICA OPZIONALE**  
**MONOBLOCK CETOP 3 WITH A-B PORTS ON SIDE 3/8" BSP, P-T BACK 1/2" BSP WITH OPTIONAL VENTING VALVE**

**E\_06 - 21 - 38 - \_\_\_ - 1**

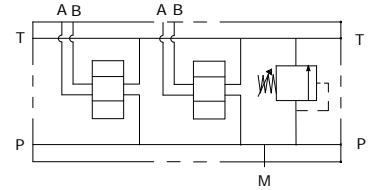
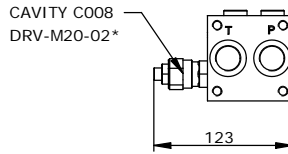
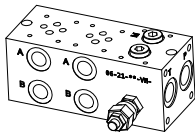

**E\_06 - 21 - 38 - \_\_\_ - 2**

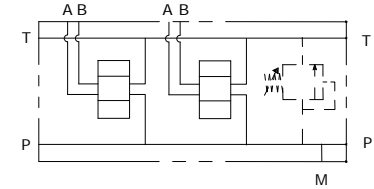
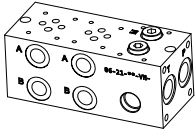

**E\_06 - 21 - 38 - \_\_\_ - 3**

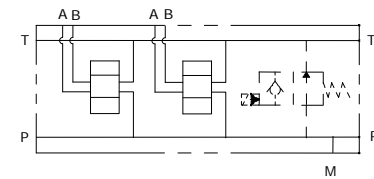
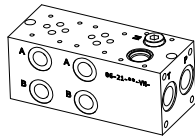

**E\_06 - 21 - 38 - \_\_\_ - 4**

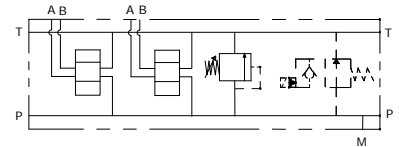
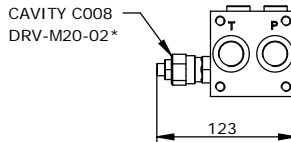
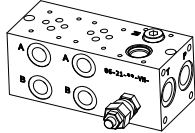

**E\_06 - 21 - 38 - \_\_\_ - 5**

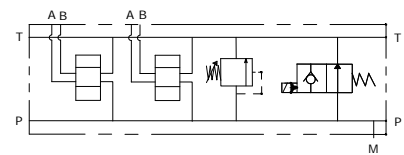
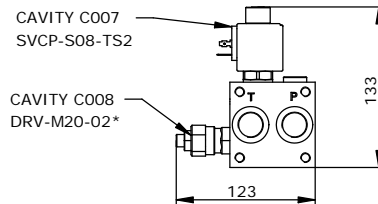
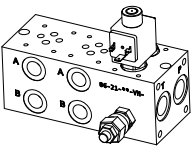

**E\_06 - 21 - 38 - \_\_\_ - 6**

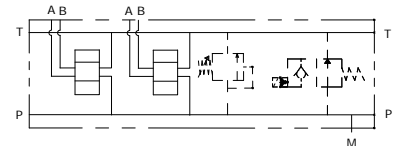
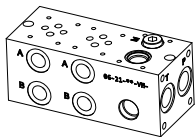

**E\_06 - 21 - 38 - \_\_\_\_\_**

**S = STEEL**  
**A = ALUMINUM**

MOUNTING POSITIONS: 01-10

0 = WITHOUT RELIEF VALVE  
 1 = WITH RELIEF VALVE  
 2 = RELIEF VALVE READY  
 3 = VENTING VALVE READY  
 4 = WITH R.V. AND V.V. READY  
 5 = WITH R.V. AND V.V.  
 6 = V.V. READY AND R.V. READY

0 = WITHOUT R.V.  
 1 = 5-50 BAR  
 2 = 20-110 BAR  
 3 = 50-220 BAR  
 4 = 100-350 BAR  
 5 = 100-420 BAR

0 = WITHOUT RELIEF VALVE  
 H = HEX. HEAD SCREW    K = KNOB    C = COVER CAP    I = NOT ADJUSTABLE



**SEALS**  
 N = BUNA  
 V = VITON

**VENTING VALVE**  
 000 = WITHOUT V.V.  
 TS2 = NORMALLY OPEN

**VENTING VALVE**  
 0 = NO MANUAL OVERRIDE  
 3 = PUSH PIN  
 4 = PUSH BOTTON  
 5 = HEX. ALLEN

**CONNECTOR TYPE**  
 0 = WITHOUT COIL  
 C = CAVI / LEADS  
 D = DIN 43650  
 G = DEUTSCH DT04-2P  
 A = AMP JUNIOR

**TENSIONE / VOLTAGE**  
 000 = WITHOUT COIL  
 D12 = 12 VDC  
 D24 = 24 VDC  
 220 = 220 RAC

\*see **CARTDRIGE VALVES** catalog

WWW.GPA.BY

**MONOBLOCCO CETOP 3 CON UTILIZZI A-B LAT. 3/8" BSP P-T POST. 1/2" BSP  
MONOBLOCK CETOP 3 WITH A-B PORTS ON SIDE 3/8" BSP P-T BACK 1/2" BSP**

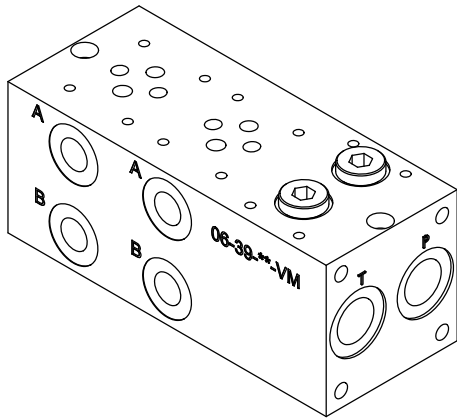

Schema idraulico  
Hydraulic diagram

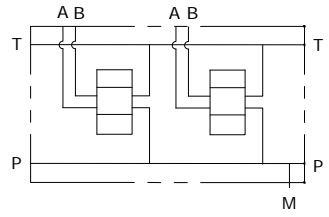

n°2 BSP1/2"G  
OR 2106 SIDE

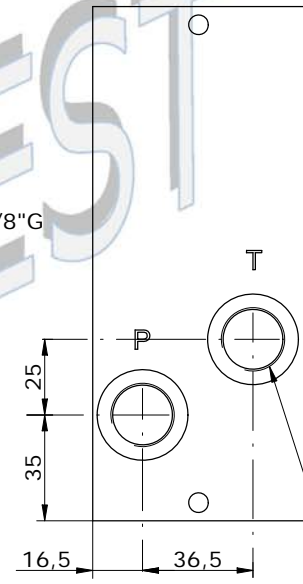
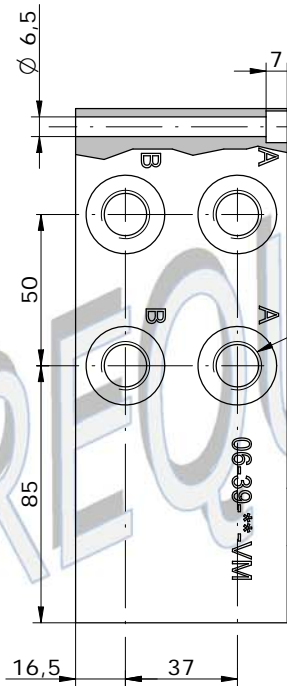
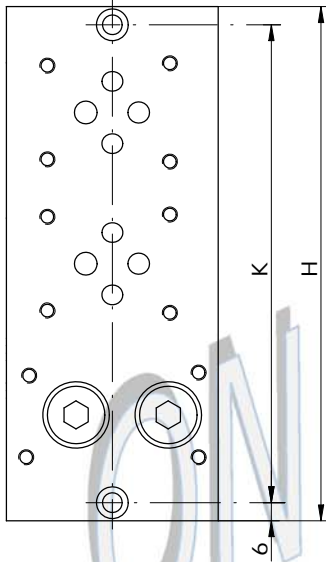
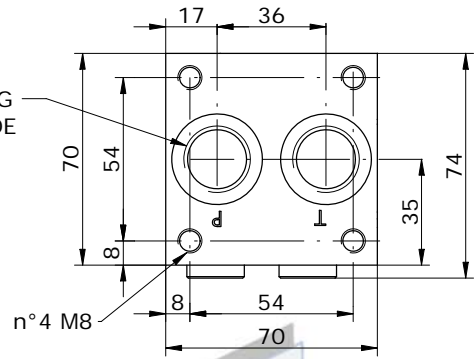

n°2 BSP1/2"G

n°4 M8

n°2 BSP1/2"G  
OR 2106 SIDE

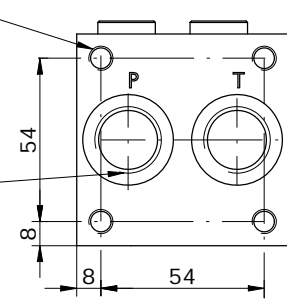

**E\_ 06 - 39 - 38 - \_\_\_ - 0**

POST	01	02	03	04	05	06	07	08	09	10
H	120	170	220	270	320	370	420	470	520	570
K	108	158	208	258	308	358	408	458	508	558

**MONOBLOCCO CETOP 3 CON UTILIZZI A-B LAT. 3/8" BSP P-T POST. 1/2" BSP  
MONOBLOCK CETOP 3 WITH A-B PORTS ON SIDE 3/8" BSP P-T BACK 1/2" BSP**

**E\_06 - 39 - 38 - \_\_\_ - 1**

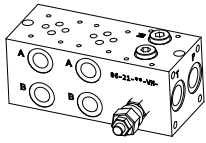

CAVITY C008  
DRV-M20-02\*

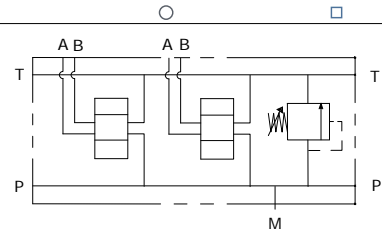
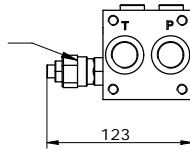

**E\_06 - 39 - 38 - \_\_\_ - 2**

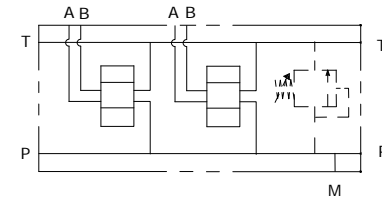
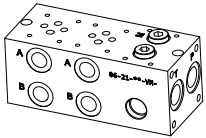

**E\_06 - 39 - 38 - \_\_\_ - 3**

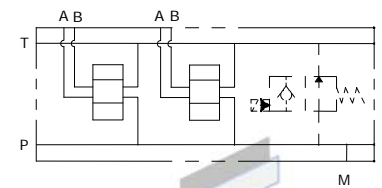
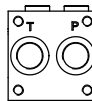
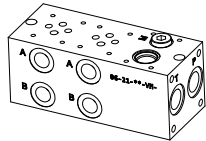

**E\_06 - 39 - 38 - \_\_\_ - 4**

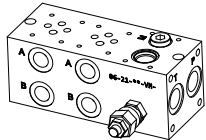

CAVITY C008  
DRV-M20-02\*

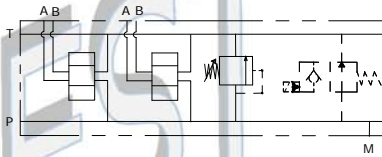
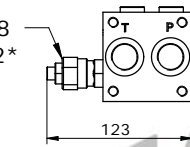

**E\_06 - 39 - 38 - \_\_\_ - 5**

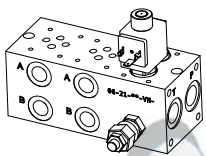

CAVITY C007  
SVCP-S08-TS2\*

CAVITY C008  
DRV-M20-02\*

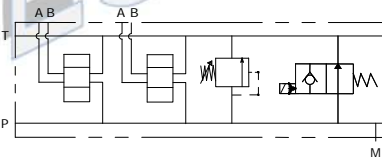
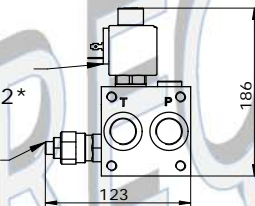

**E\_06 - 39 - 38 - \_\_\_ - 6**

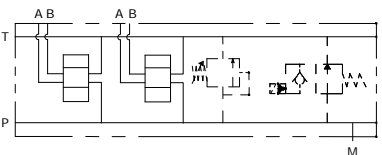
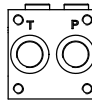
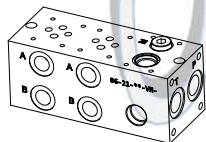

**E\_06 - 39 - 38 - \_\_\_\_\_**

MOUNTING POSITIONS: 01-10

S = STEEL  
A = ALUMINUM

- 0 = WITHOUT RELIEF VALVE
- 1 = WITH RELIEF VALVE
- 2 = RELIEF VALVE READY
- 3 = VENTING VALVE READY
- 4 = WITH R.V. AND V.V. READY
- 5 = WITH R.V. AND V.V.
- 6 = V.V. READY AND R.V. READY

- 0 = WITHOUT R.V.
- 1 = 5-50 BAR
- 2 = 20-110 BAR
- 3 = 50-220 BAR
- 4 = 100-350 BAR
- 5 = 100-420 BAR

- 0 = WITHOUT RELIEF VALVE
- H = HEX. HEAD SCREW
- K = KNOB
- C = COVER CAP
- I = NOT ADJUSTABLE



SEALS  
N = BUNA  
V = VITON

VENTING VALVE  
000 = WITHOUT V.V.  
TS2 = NORMALLY OPEN

VENTING VALVE  
0 = NO MANUAL OVERRIDE  
3 = PUSH PIN  
4 = PUSH BOTTON  
5 = HEX. ALLEN

CONNECTOR TYPE  
O = WITHOUT COIL  
C = CAVI / LEADS  
D = DIN 43650  
G = DEUTSCH DT04-2P  
A = AMP JUNIOR

TENSIONE / VOLTAGE  
000 = WITHOUT COIL  
D12 = 12 VDC  
D24 = 24 VDC  
220 = 220 RAC

\*see **CARTDRIGE VALVES** catalog

WWW.GPA.BY

**MONOBLOCCO A-B LATERALI 3/8" P-T 1/2" BSP CON VALVOLA EL. OPZIONALE,  
CIRCUITO IN SERIE**  
**MONOBLOCK A-B ON SIDE 3/8" P-T 1/2" BSP WITH OPTIONAL VENTING VALVE,  
SERIES CIRCUIT**

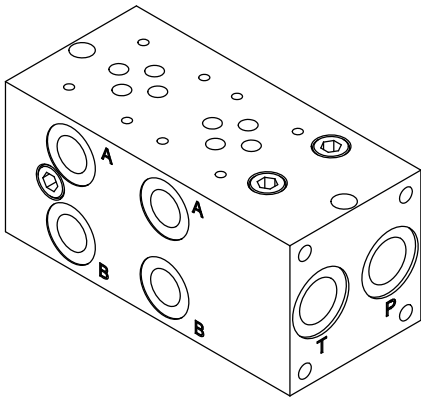

Schema idraulico  
Hydraulic diagram

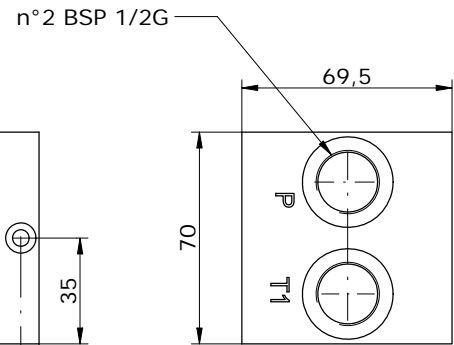
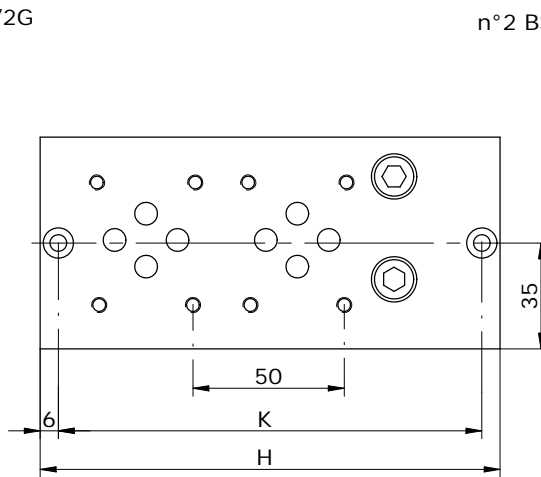
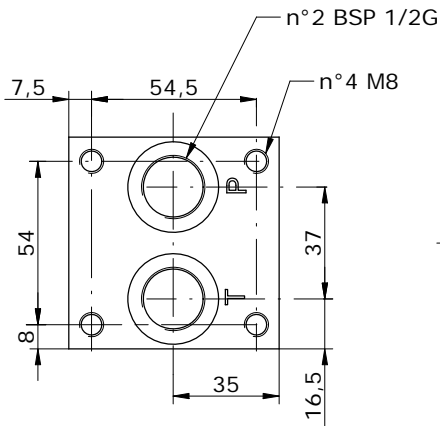
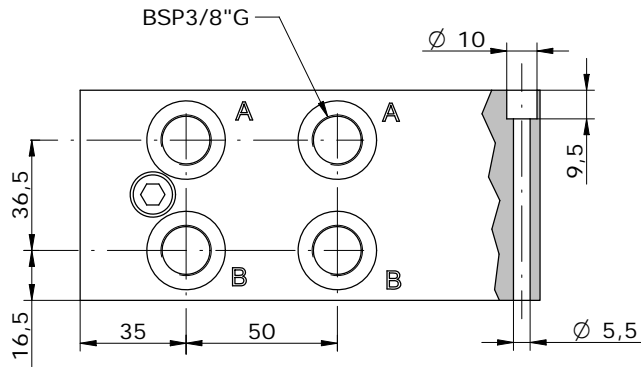
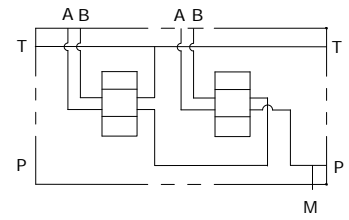

**E\_06 - 19 - 38 - \_\_\_ - 0**

POS.	02	03	04	05	06	07	08
H	152	202	252	302	352	402	452
K	140	190	240	290	340	390	440

**MONOBLOCCO A-B LATERALI 3/8" P-T 1/2" BSP CON VALVOLA EL. OPZIONALE,  
CIRCUITO IN SERIE**  
**MONOBLOCK A-B ON SIDE 3/8" P-T 1/2" BSP WITH OPTIONAL VENTING VALVE,  
SERIES CIRCUIT**

**E\_06 - 19 - 38 - \_\_\_ - 1**

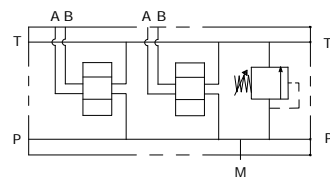
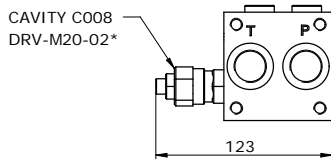
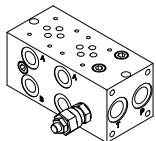

**E\_06 - 19 - 38 - \_\_\_ - 2**

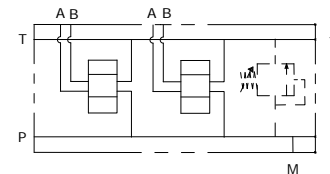
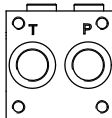
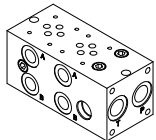

**E\_06 - 19 - 38 - \_\_\_ - 3**

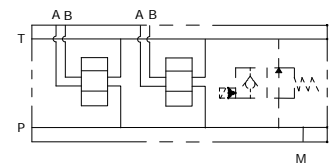
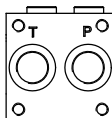
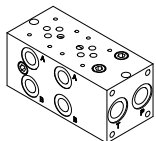

**E\_06 - 19 - 38 - \_\_\_ - 4**

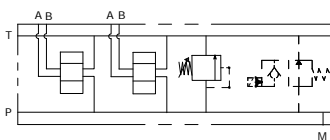
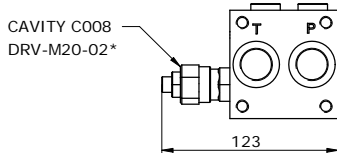
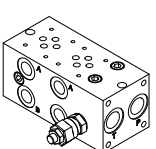

**E\_06 - 19 - 38 - \_\_\_ - 5**

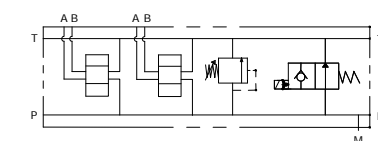
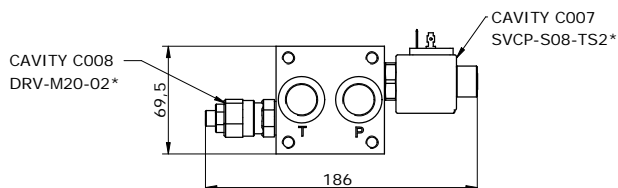
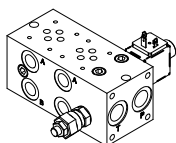

**E\_06 - 19 - 38 - \_\_\_ - 6**

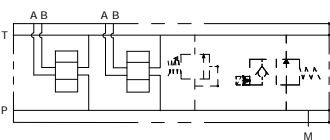
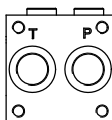
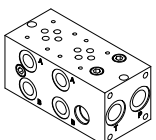

**E\_06 - 19 - 38 - \_\_\_ - - - - -**

**S = STEEL**  
**A = ALUMINUM**

MOUNTING POSITIONS: 01-10

**0 = WITHOUT RELIEF VALVE**  
**1 = WITH RELIEF VALVE**  
**2 = RELIEF VALVE READY**  
**3 = VENTING VALVE READY**  
**4 = WITH R.V. AND V.V. READY**  
**5 = WITH R.V. AND V.V.**  
**6 = V.V. READY AND R.V. READY**

**0 = WITHOUT R.V.**  
**1 = 5-50 BAR**  
**2 = 20-110 BAR**  
**3 = 50-220 BAR**  
**4 = 100-350 BAR**  
**5 = 100-420 BAR**

**0 = WITHOUT RELIEF VALVE**  
**H = HEX. HEAD SCREW**

**K = KNOB**

**C = COVER CAP**

**I = NOT ADJUSTABLE**



**SEALS**  
**N = BUNA**  
**V = VITON**

**VENTING VALVE**  
**000 = WITHOUT V.V.**  
**TS2 = NORMALLY OPEN**

**VENTING VALVE**  
**0 = NO MANUAL OVERRIDE**  
**3 = PUSH PIN**  
**4 = PUSH BOTTON**  
**5 = HEX. ALLEN**

**CONNECTOR TYPE**  
**0 = WITHOUT COIL**  
**C = CAVI / LEADS**  
**D = DIN 43650**  
**G = DEUTSCH DT04-2P**  
**A = AMP JUNIOR**

**TENSIONE / VOLTAGE**  
**000 = WITHOUT COIL**  
**D12 = 12 VDC**  
**D24 = 24 VDC**  
**220 = 220 RAC**

\*see *CARTDRIGE VALVES* catalog

WWW.GPA.BY

**MONOBLOCCO CETOP 3 CON UTILIZZI A-B LAT 1/2" BSP . P-T LAT 3/4" BSP CON VALVOLA ELETTRICA OPZIONALE**  
**MONOBLOCK CETOP 3 WITH A-B PORTS ON SIDE 1/2" BSP, P-T ON SIDE 3/4" BSP WITH OPTIONAL VENTING VALVE**

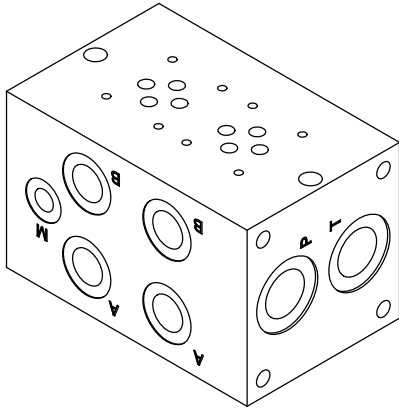

Schema idraulico  
Hydraulic diagram

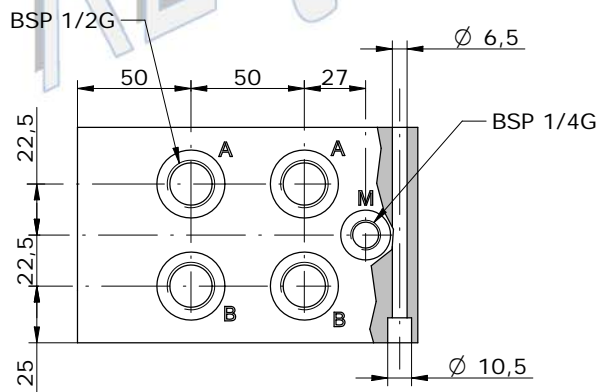
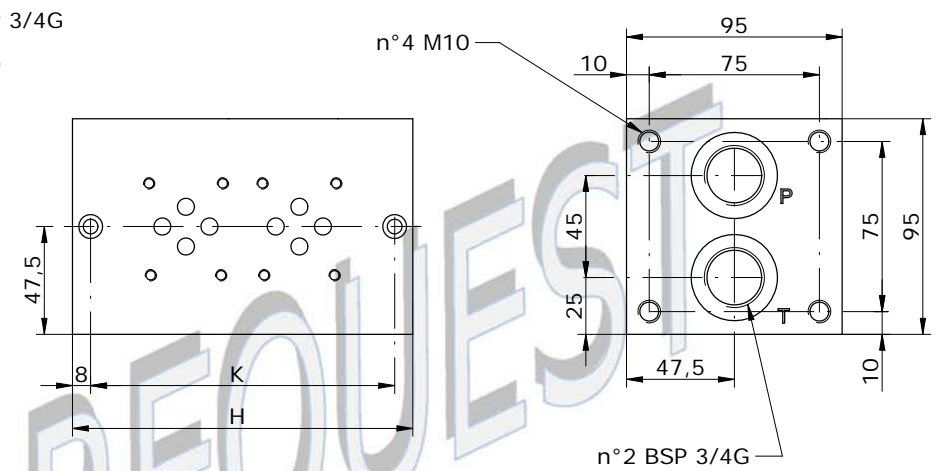
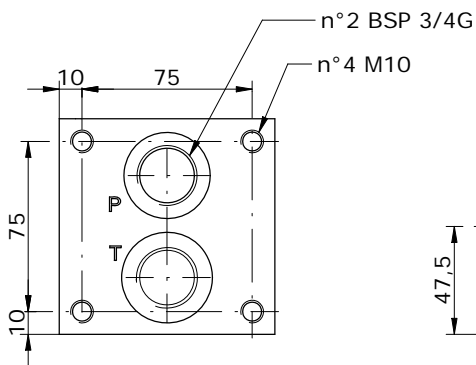
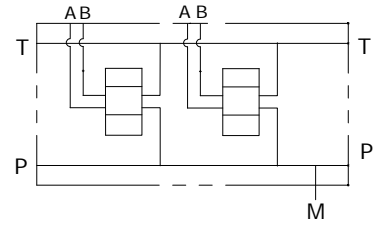

**E\_06 - 30 - 12 - \_\_\_ - 0**

POS.	01	02	03	04	05	06	07	08
H	120	150	200	250	300	350	400	450
K	104	134	184	234	284	334	384	434



**MONOBLOCCO CETOP 3 CON UTILIZZI A-B LAT 1/2" BSP . P-T LAT 3/4" BSP CON VALVOLA ELETTRICA OPZIONALE**  
**MONOBLOCK CETOP 3 WITH A-B PORTS ON SIDE 1/2" BSP, P-T ON SIDE 3/4" BSP WITH OPTIONAL VENTING VALVE**

**E\_06 - 30 - 12 - \_\_\_ - 1**

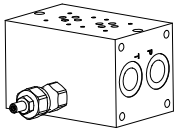

CAVITY C025  
DRV-M26-01\*

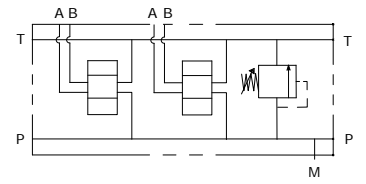
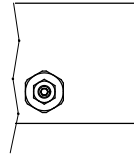
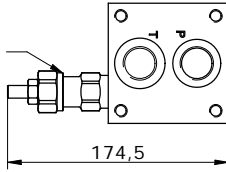

**E\_06 - 30 - 12 - \_\_\_ - 2**

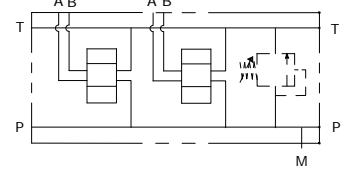
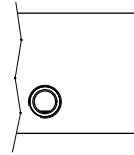
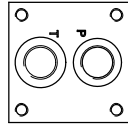
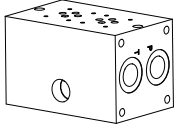

**E\_06 - 30 - 12 - \_\_\_ - 3**

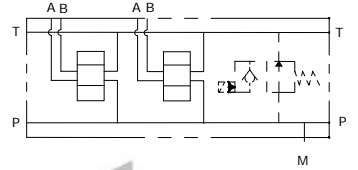
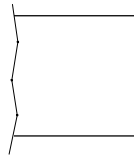
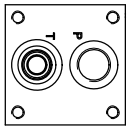
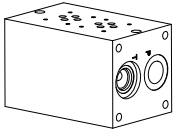

**E\_06 - 30 - 12 - \_\_\_ - 4**

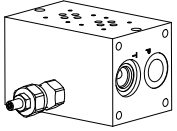

CAVITY C025  
DRV-M26-01\*

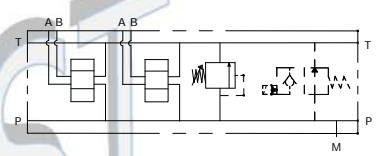
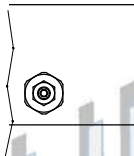
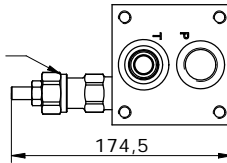

**E\_06 - 30 - 12 - \_\_\_ - 5**

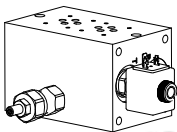

CAVITY C025  
DRV-M26-01\*

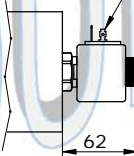
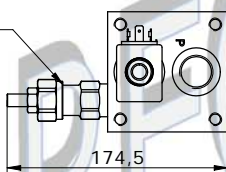

CAVITY C035  
SVCP-S10-TS2\*

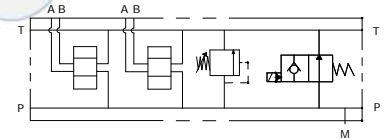

**E\_06 - 30 - 12 - \_\_\_ - 6**

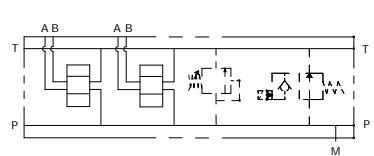
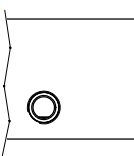
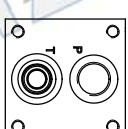
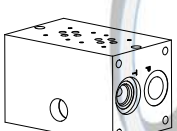

**E\_06 - 30 - 12 - \_\_\_ - 08**

**S** = STEEL  
**A** = ALUMINUM

MOUNTING POSITIONS: 01-08

**0** = WITHOUT RELIEF VALVE  
**1** = WITH RELIEF VALVE  
**2** = RELIEF VALVE READY  
**3** = VENTING VALVE READY  
**4** = WITH R.V. AND V.V. READY  
**5** = WITH R.V. AND V.V.  
**6** = V.V. READY AND R.V. READY

**0** = WITHOUT RELIEF VALVE  
**1** = 5-55 BAR  
**2** = 25-110 BAR  
**3** = 75-250 BAR

**0** = WITHOUT RELIEF VALVE  
**H** = HEX. HEAD SCREW    **K** = KNOB    **C** = COVER CAP    **I** = NOT ADJUSTABLE



**SEALS**  
**N** = BUNA  
**V** = VITON

**VENTING VALVE**  
**000** = WITHOUT V.V.  
**TS2** = NORMALLY OPEN

**VENTING VALVE**  
**0** = NO MANUAL OVERRIDE  
**2** = PUSH AND TWIST  
**4** = PUSH BOTTON

**CONNECTOR TYPE**  
**0** = WITHOUT COIL  
**C** = CAVI / LEADS  
**D** = DIN 43650  
**G** = DEUTSCH DT04-2P  
**A** = AMP JUNIOR

**TENSIONE / VOLTAGE**  
**000** = WITHOUT COIL  
**D12** = 12 VDC  
**D24** = 24 VDC  
**220** = 220 RAC

\*see *CARTDRIGE VALVES* catalog

**MONOBLOCCO A-B LATERALI 1/2" P-T 3/4" BSP CON VALVOLA EL. OPZIONALE**  
**MONOBLOCK A-B ON SIDE 1/2" P-T 3/4" BSP WITH OPTIONAL VENTING VALVE**

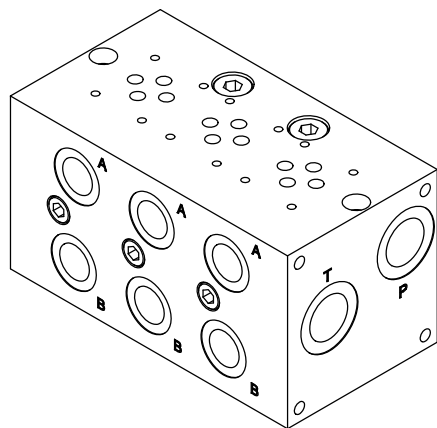

Schema idraulico  
Hydraulic diagram

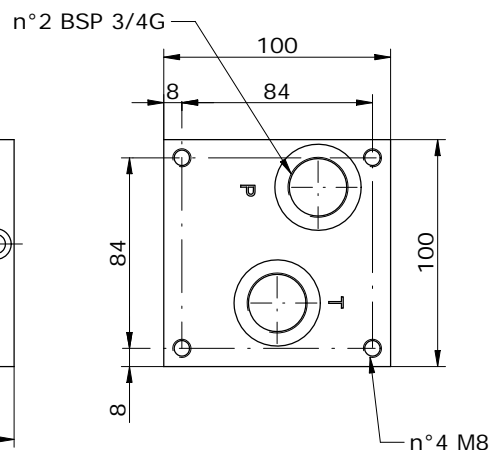
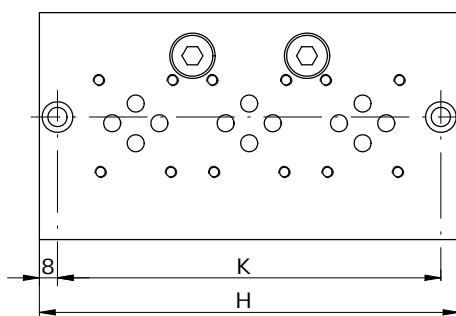
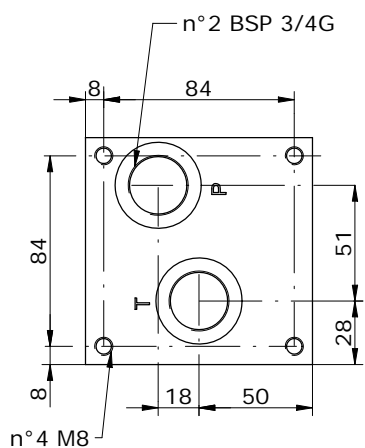
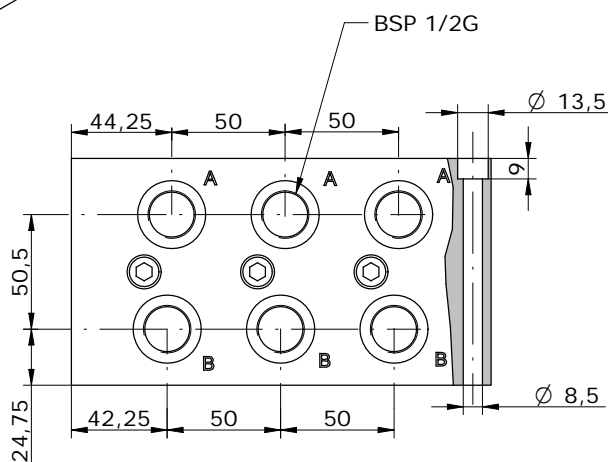
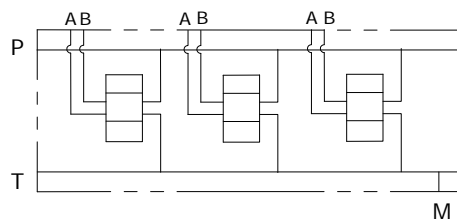

**E\_06 - 28 - 12 - \_\_\_ - 0**

POS.	02	03	04	05	06
H	145	185	235	285	335
K	129	169	219	269	319

**MONOBLOCCO A-B LATERALI 1/2" P-T 3/4" BSP CON VALVOLA EL. OPZIONALE  
MONOBLOCK A-B ON SIDE 1/2" P-T 3/4" BSP WITH OPTIONAL VENTING VALVE**

E\_06 - 28 - 12 - \_\_\_ - 1

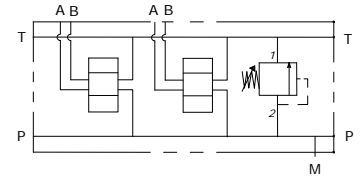
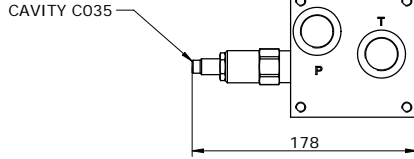
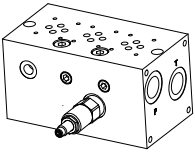

E\_06 - 28 - 12 - \_\_\_ - 2

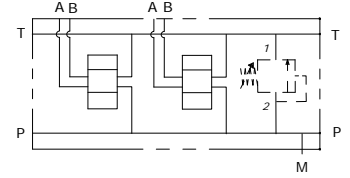
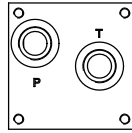
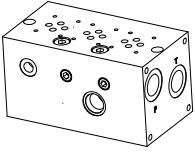

E\_06 - 28 - 12 - \_\_\_ - 3

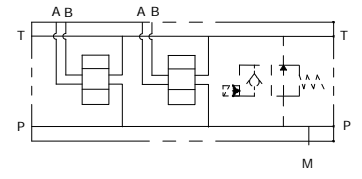
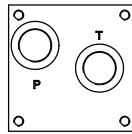
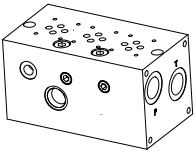

E\_06 - 28 - 12 - \_\_\_ - 4

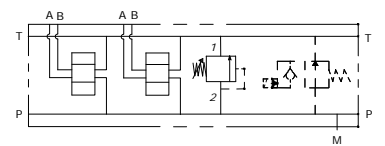
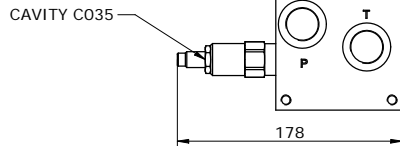
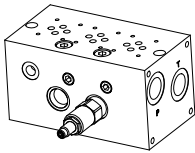

E\_06 - 28 - 12 - \_\_\_ - 5

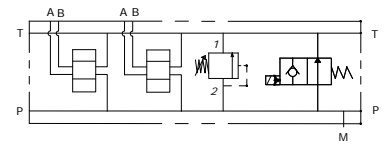
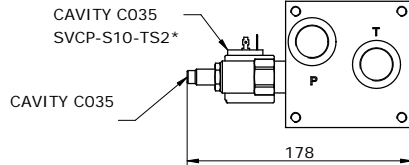
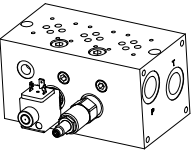

E\_06 - 28 - 12 - \_\_\_ - 6

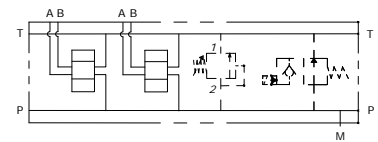
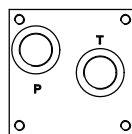
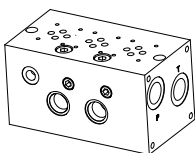

**E\_06 - 28 - 12 - \_\_\_\_\_**

S = STEEL  
A = ALUMINUM

MOUNTING POSITIONS: 02-06

- 0 = WITHOUT RELIEF VALVE
- 1 = WITH RELIEF VALVE
- 2 = RELIEF VALVE READY
- 3 = VENTING VALVE READY
- 4 = WITH R.V. AND V.V. READY
- 5 = WITH R.V. AND V.V
- 6 = V.V. READY AND R.V. READY

- 0 = WITHOUT RELIEF VALVE
- 1 = < 55 BAR
- 2 = < 118 BAR
- 3 = < 207 BAR
- 4 = < 297 BAR

- 0 = WITHOUT RELIEF VALVE
- H = HEX. HEAD SCREW
- K = KNOB
- C = COVER CAP
- I = NOT ADJUSTABLE



SEALS  
N = BUNA  
V = VITON

VENTING VALVE  
000 = WITHOUT V.V.  
TS2 = NORMALLY OPEN

VENTING VALVE  
0 = NO MANUAL OVERRIDE  
2 = PUSH AND TWIST  
4 = PUSH BOTTOM

CONNECTOR TYPE  
0 = WITHOUT COIL  
C = CAVI / LEADS  
D = DIN 43650  
G = DEUTSCH DT04-2P  
A = AMP JUNIOR

TENSIONE / VOLTAGE  
000 = WITHOUT COIL  
D12 = 12 VDC  
D24 = 24 VDC  
D26 = 26 VDC

\*see *CARTDRIGE VALVES* catalog

WWW.GPA.BY

**MONOBLOCCO A-B POSTERIORI 3/8", P-T 1/2", CON VALVOLA ELETTRICA OPZIONALE**  
**MONOBLOCK A-B BACK PORTS 3/8" P-T 1/2" WITH OPTIONAL VENTING VALVE**

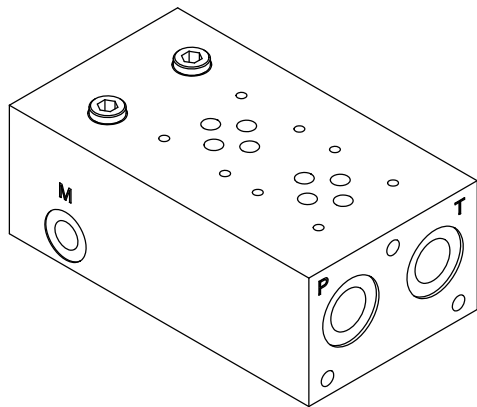

Schema idraulico  
Hydraulic diagram

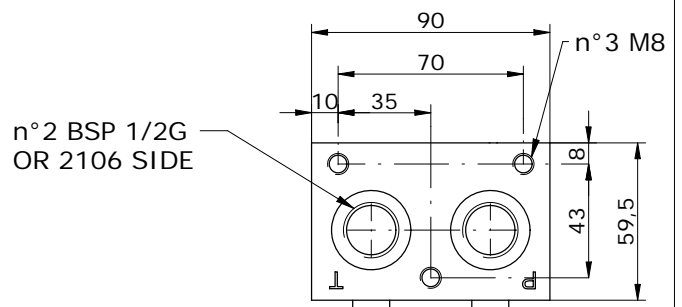
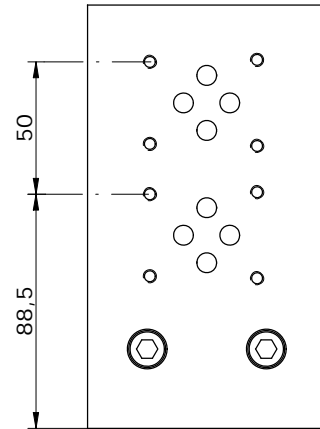
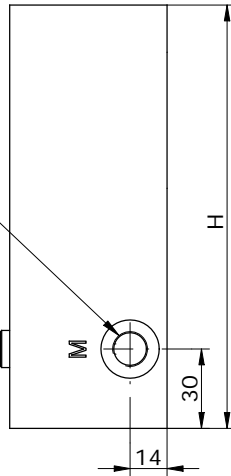
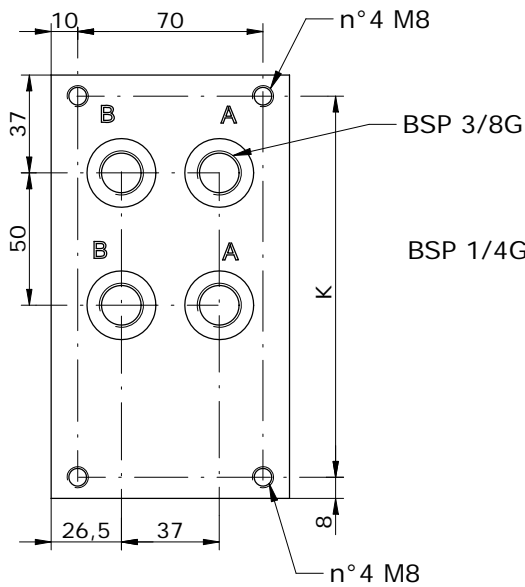
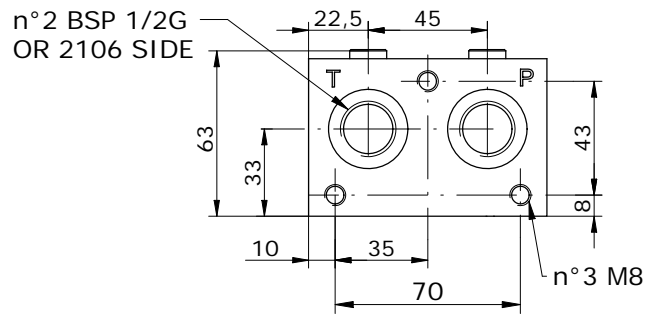
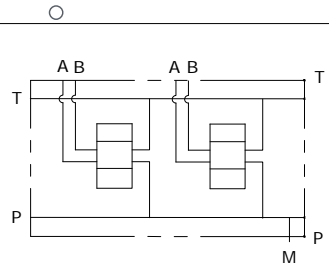

**E\_06 - 13 - 38 - \_\_\_ - 0**

POS.	01	02	03	04	05	06	07	08	09	10
H	110	160	210	260	310	360	410	460	510	560
K	94	144	194	244	294	344	394	444	494	544

**MONOBLOCCO A-B POSTERIORI 3/8", P-T 1/2", CON VALVOLA ELETTRICA OPZIONALE**  
**MONOBLOCK A-B BACK PORTS 3/8" P-T 1/2" WITH OPTIONAL VENTING VALVE**

**E\_06 - 13 - 38 - \_\_\_ - 1**

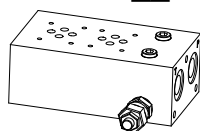

CAVITY C008  
DRV-M20-02\*

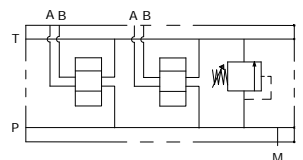
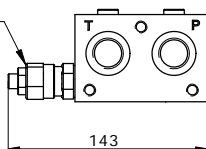

**E\_06 - 13 - 38 - \_\_\_ - 2**

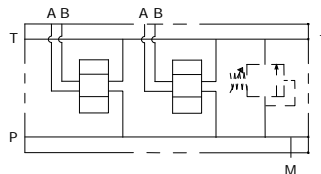
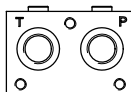
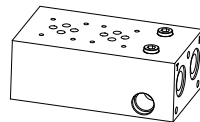

**E\_06 - 13 - 38 - \_\_\_ - 3**

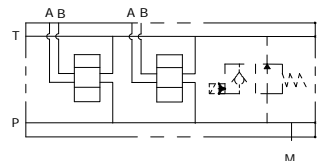
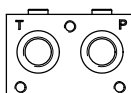
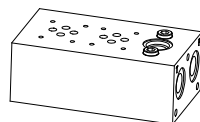

**E\_06 - 13 - 38 - \_\_\_ - 4**

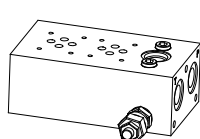

CAVITY C008  
DRV-M20-02\*

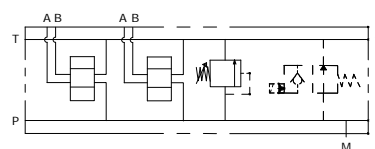
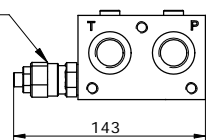

**E\_06 - 13 - 38 - \_\_\_ - 5**

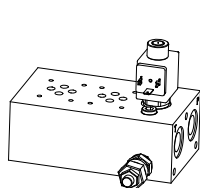

CAVITY C007  
SVCP-S08-TS2\*

CAVITY C008  
DRV-M20-02\*

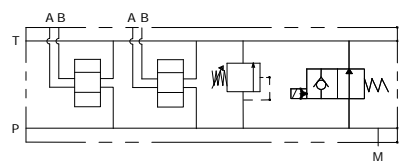
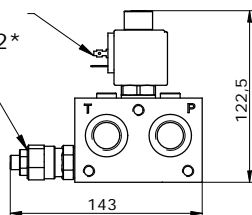

**E\_06 - 13 - 38 - \_\_\_ - 6**

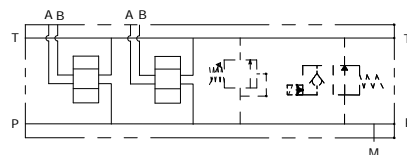
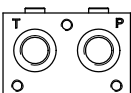
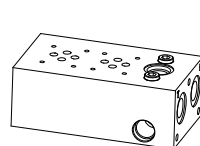

**E\_06 - 13 - 38 - \_\_\_\_\_**

**S** = STEEL  
**A** = ALUMINUM

MOUNTING POSITIONS: 01-10

**0** = WITHOUT RELIEF VALVE  
**1** = WITH RELIEF VALVE  
**2** = RELIEF VALVE READY  
**3** = VENTING VALVE READY  
**4** = WITH R.V. AND V.V. READY  
**5** = WITH R.V. AND V.V.  
**6** = V.V. READY AND R.V. READY

**0** = WITHOUT R.V.  
**1** = 5-50 BAR  
**2** = 20-110 BAR  
**3** = 50-220 BAR  
**4** = 100-350 BAR  
**5** = 100-420 BAR

**0** = WITHOUT RELIEF VALVE  
**H** = HEX. HEAD SCREW    **K** = KNOB    **C** = COVER CAP    **I** = NOT ADJUSTABLE



**SEALS**  
**N** = BUNA  
**V** = VITON

**VENTING VALVE**  
**000** = WITHOUT V.V.  
**TS2** = NORMALLY OPEN

**VENTING VALVE**  
**0** = NO MANUAL OVERRIDE  
**3** = PUSH PIN  
**4** = PUSH BOTTON  
**5** = HEX. ALLEN

**CONNECTOR TYPE**  
**0** = WITHOUT COIL  
**C** = CAVI / LEADS  
**D** = DIN 43650  
**G** = DEUTSCH DT04-2P  
**A** = AMP JUNIOR

**TENSIONE / VOLTAGE**  
**000** = WITHOUT COIL  
**D12** = 12 VDC  
**D24** = 24 VDC  
**220** = 220 RAC

\*see **CARTDRIGE VALVES** catalog

WWW.GPA.BY

**MONOBLOCCO A-B POSTERIORI 1/2", P-T 1/2" CON VALVOLA ELETTRICA OPZIONALE**  
**MONOBLOCK A-B BACK PORTS 1/2" P-T 1/2" WITH OPTIONAL VENTING VALVE**

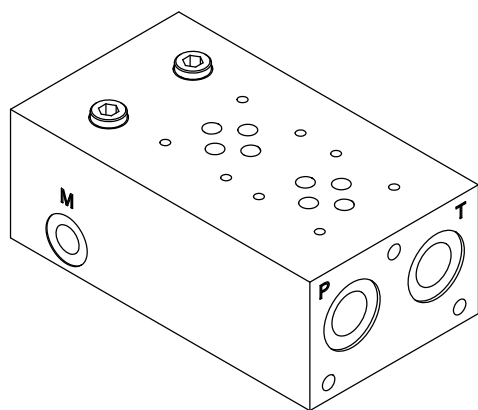

Schema idraulico  
Hydraulic diagram

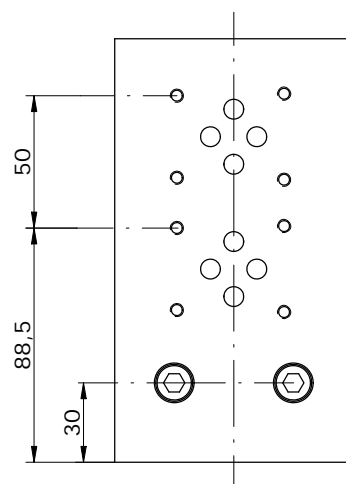
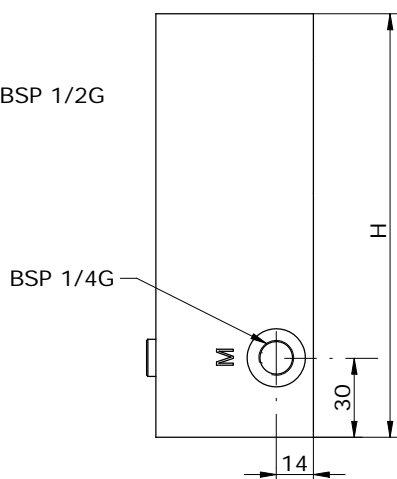
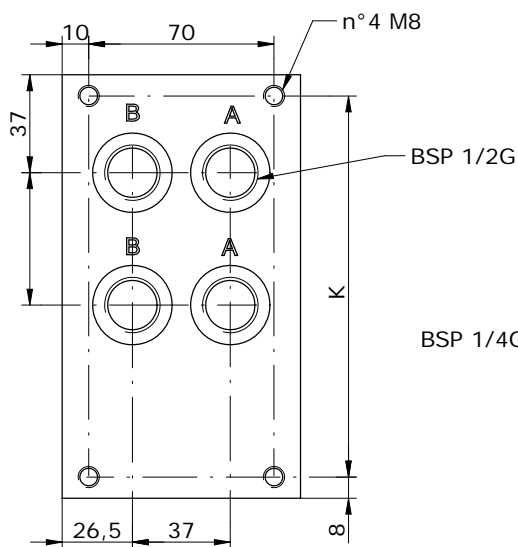
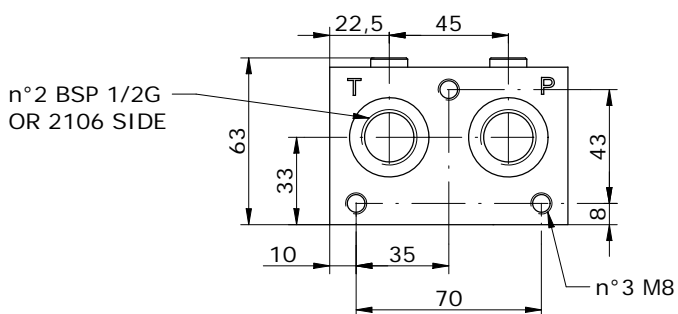
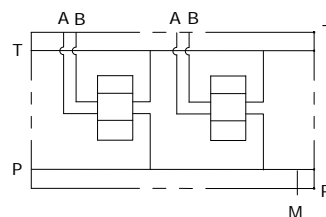

**E\_06 - 13 - 12 - \_\_\_ - 0**

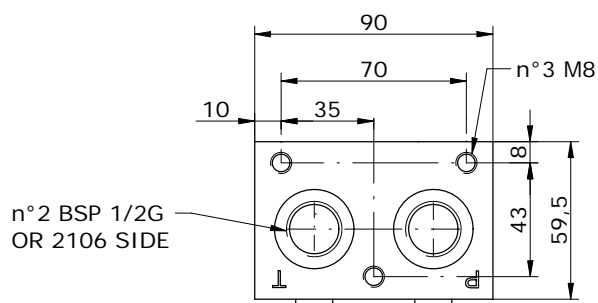

POS.	01	02	03	04	05	06	07	08	09	10
H	110	160	210	260	310	360	410	460	510	560
K	94	144	194	244	294	344	394	444	494	544

**MONOBLOCCO A-B POSTERIORI 1/2", P-T 1/2" CON VALVOLA ELETTRICA OPZIONALE**  
**MONOBLOCK A-B BACK PORTS 1/2" P-T 1/2" WITH OPTIONAL VENTING VALVE**

**E\_06 - 13 - 12 - \_ - 1**

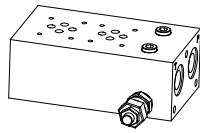

CAVITY C008  
 DRV-M20-02\*

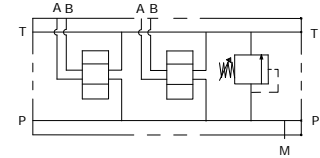
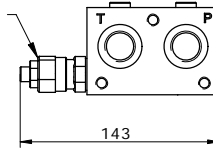

**E\_06 - 13 - 12 - \_ - 2**

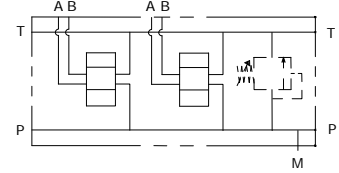
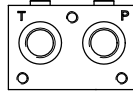
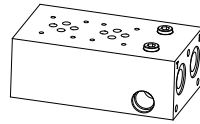

**E\_06 - 13 - 12 - \_ - 3**

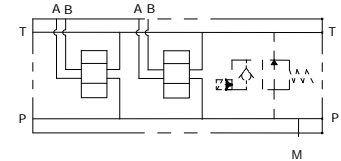
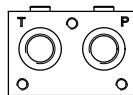
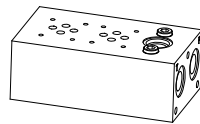

**E\_06 - 13 - 12 - \_ - 4**

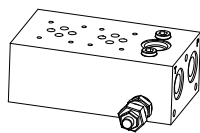

CAVITY C008  
 DRV-M20-02\*

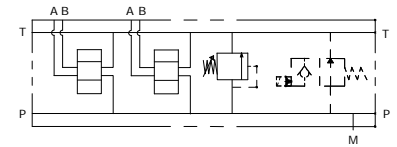
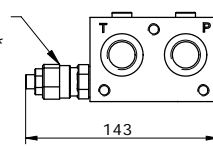

**E\_06 - 13 - 12 - \_ - 5**

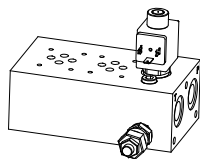

CAVITY C007  
 SVCP-S08-TS2\*

CAVITY C008  
 DRV-M20-02\*

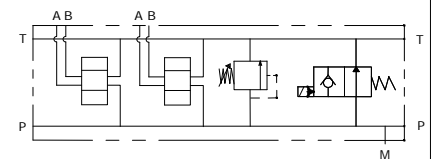
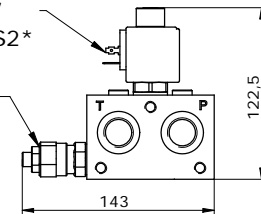

**E\_06 - 13 - 12 - \_ - 6**

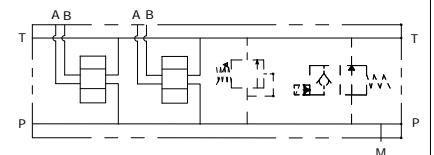
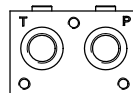
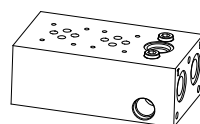

**E\_06 - 13 - 12 - \_ - - - - - - - - - - - - - - -**

**S** = STEEL  
**A** = ALUMINUM

MOUNTING POSITIONS: 01-10

**0** = WITHOUT RELIEF VALVE  
**1** = WITH RELIEF VALVE  
**2** = RELIEF VALVE READY  
**3** = VENTING VALVE READY  
**4** = WITH R.V. AND V.V. READY  
**5** = WITH R.V. AND V.V  
**6** = V.V. READY AND R.V. READY

**0** = WITHOUT R.V.  
**1** = 5-50 BAR  
**2** = 20-110 BAR  
**3** = 50-220 BAR  
**4** = 100-350 BAR  
**5** = 100-420 BAR

**0** = WITHOUT RELIEF VALVE  
**H** = HEX. HEAD SCREW    **K** = KNOB    **C** = COVER CAP    **I** = NOT ADJUSTABLE



**SEALS**  
**N** = BUNA  
**V** = VITON

**VENTING VALVE**  
**000** = WITHOUT V.V.  
**TS2** = NORMALLY OPEN

**VENTING VALVE**  
**0** = NO MANUAL OVERRIDE  
**3** = PUSH PIN  
**4** = PUSH BOTTON  
**5** = HEX. ALLEN

**CONNECTOR TYPE**  
**0** = WITHOUT COIL  
**C** = CAVI / LEADS  
**D** = DIN 43650  
**G** = DEUTSCH DT04-2P  
**A** = AMP JUNIOR

**TENSIONE / VOLTAGE**  
**000** = WITHOUT COIL  
**D12** = 12 VDC  
**D24** = 24 VDC  
**220** = 220 RAC

\*see *CARTDRIGE VALVES* catalog

WWW.GPA.BY

**MONOBLOCCO A-B POSTERIORI 3/8" LATERALI 1/4" (3/8"), P-T 1/2" BSP**  
**MONOBLOCK A-B BACK PORTS 3/8" ON SIDE 1/4" (3/8"), P-T 1/2" BSP**

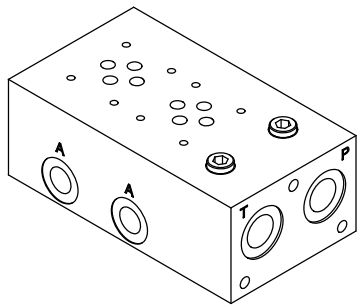

Schema idraulico  
Hydraulic diagram

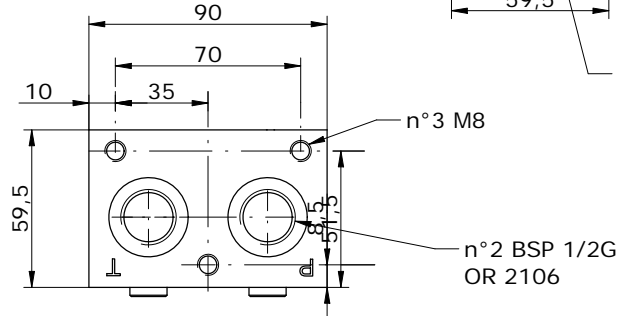
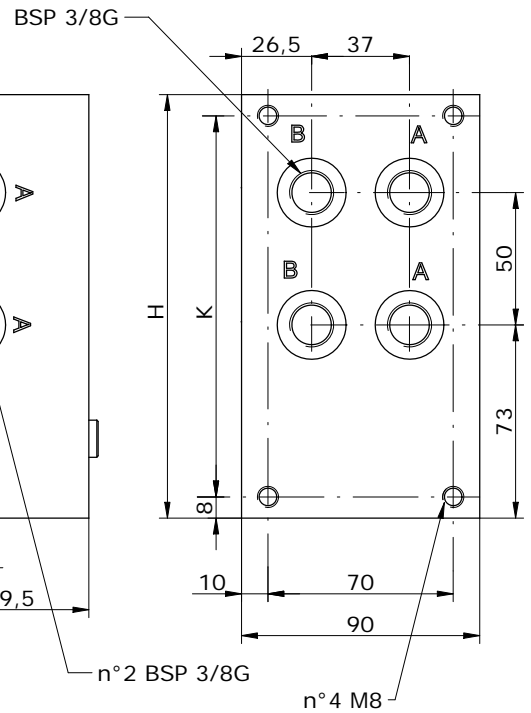
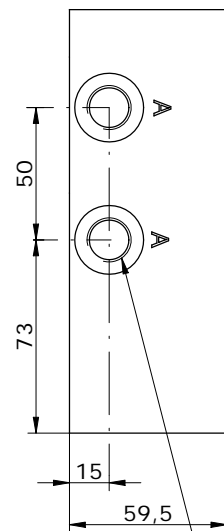
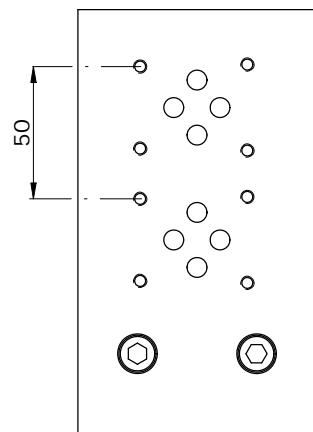
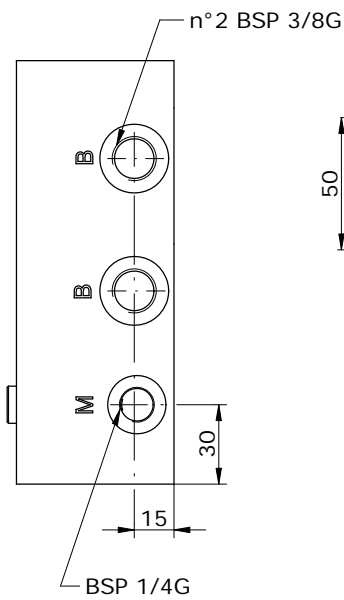
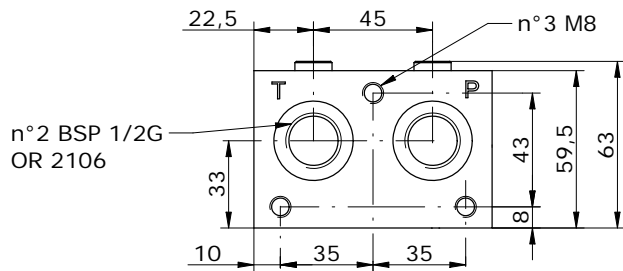
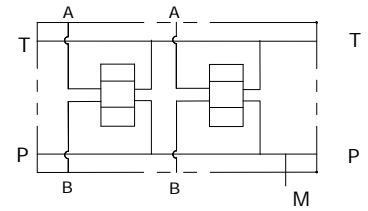

**E\_06 - 25 - 38 - \_\_\_ - \_\_\_ - 0**

POS.	01	02	03	04	05	06	07	08	09	10
H	110	160	210	260	310	360	410	460	510	560
K	94	144	194	244	294	344	394	444	494	544



**MONOBLOCCO A-B POSTERIORI 3/8" LATERALI 1/4" (3/8"), P-T 1/2" BSP  
MONOBLOCK A-B BACK PORTS 3/8" ON SIDE 1/4" (3/8"), P-T 1/2" BSP**

E\_06 - 25 - 38 - \_\_\_\_ - \_\_\_\_ - 1

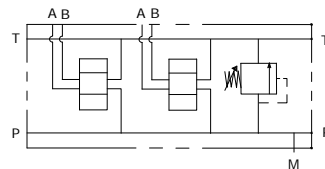
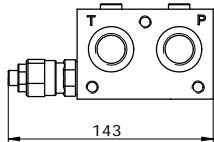
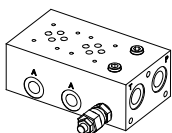

E\_06 - 25 - 38 - \_\_\_\_ - \_\_\_\_ - 2

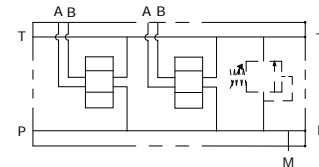
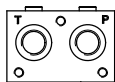
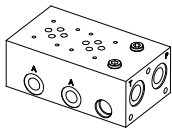

E\_06 - 25 - 38 - \_\_\_\_ - \_\_\_\_ - 3

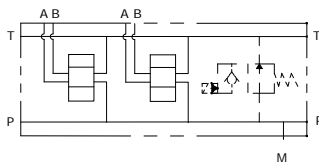
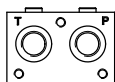
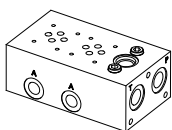

E\_06 - 25 - 38 - \_\_\_\_ - \_\_\_\_ - 4

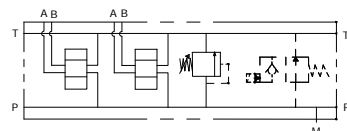
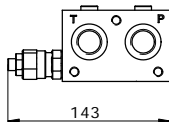
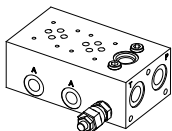

E\_06 - 25 - 38 - \_\_\_\_ - \_\_\_\_ - 5

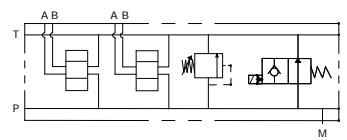
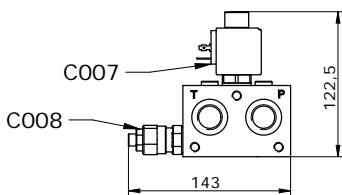
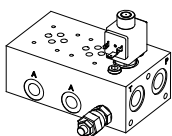

E\_06 - 25 - 38 - \_\_\_\_ - \_\_\_\_ - 6

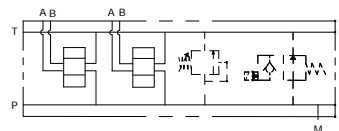
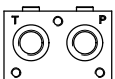
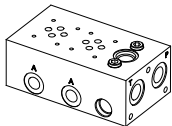

**TIPI DI REGOLAZIONE PER V. MAX  
REGULATION TYPE FOR RELIEF VALVE**

	H	VITE CON CHIAVE ESAGONALE (standard) HEXAGONAL HEAD SCREW
	K	POMOLO KNOB
	C	FISSA CON CAPPUCIO COVER CAP
	I	INVOLABILE

**E\_06 - 25 - 38 - \_\_\_\_ - \_\_\_\_ - \_\_\_\_ - \_\_\_\_**

S = STEEL  
A = ALUMINUM

MOUNTING POSITIONS: 01-10

0 = WITHOUT RELIEF VALVE  
1 = WITH RELIEF VALVE  
2 = RELIEF VALVE READY  
3 = VENTING VALVE READY  
4 = WITH R.V. AND V.V. READY  
5 = WITH R.V. AND V.V.  
6 = V.V. READY AND R.V. READY

0 = WITHOUT R.V.  
1 = 0-90 BAR  
2 = 30-150 BAR  
3 = 50-220 BAR  
4 = 80-350 BAR

0 = WITHOUT RELIEF VALVE  
H = HEX. HEAD SCREW  
K = KNOB  
C = COVER CAP  
I = NOT ADJUSTABLE

SEALS  
N = BUNA  
V = VITON

VENTING VALVE  
000 = WITHOUT V.V.  
TS2 = NORMALLY OPEN

VENTING VALVE  
0 = NO MANUAL OVERRIDE  
3 = PUSH PIN  
4 = PUSH BOTTON  
5 = HEX. ALLEN

CONNECTOR TYPE  
O = WITHOUT COIL  
C = CAVI / LEADS  
D = DIN 43650  
G = DEUTSCH DT04-2P  
A = AMP JUNIOR

TENSIONE / VOLTAGE  
000 = WITHOUT COIL  
D12 = 12 VDC  
D24 = 24 VDC  
220 = 220 VDC

WWW.GPA.BY

ELEMENTO VENTING PER E\_06-13-12/E\_06-13-38  
 VENTING ELEMENT FOR E\_06-13-12/E\_06-13-38

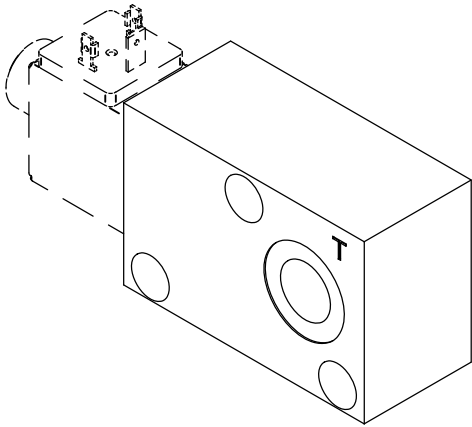

Schema idraulico  
 Hydraulic diagram

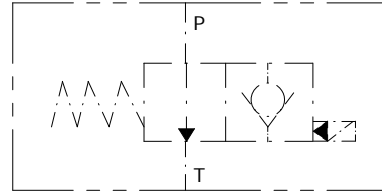

CAVITY C007  
 SVCPS08-TS2\*

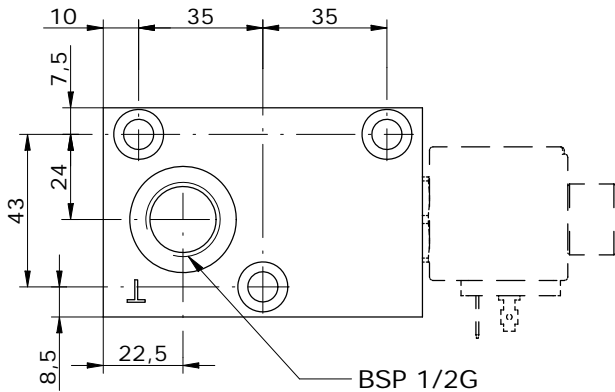
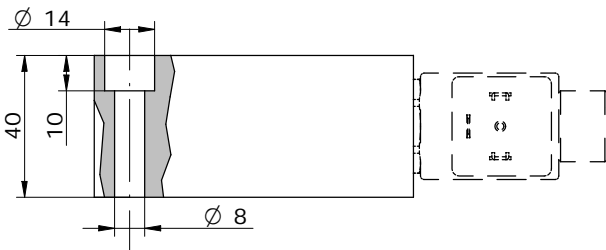
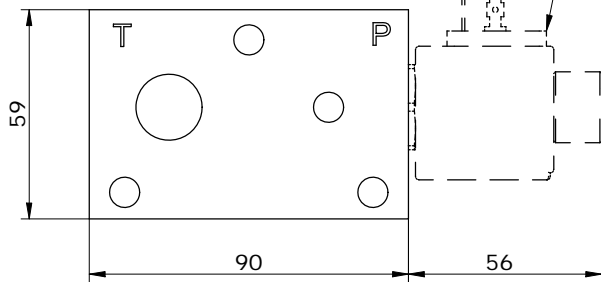

BSP 1/2G

EXAMPLE OF APPLICATION

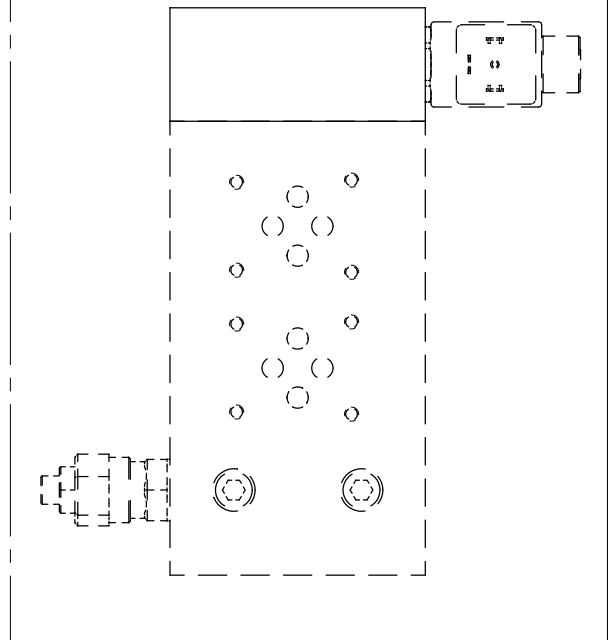

AVAILABLE FOR:

E\_06-13-38

E\_06-13-12

E\_06-25-38

**E\_06 - 04**

S = STEEL  
 A = ALUMINUM

0 = WITHOUT VENTING VALVE  
 1 = WITH VENTING VALVE  
 2 = VENTING VALVE READY

VENTING VALVE

000 = WITHOUT V.V.  
 TS2 = NORMALLY OPEN

SEALS

N = BUNA  
 V = VITON

VENTING VALVE

0 = NO MANUAL OVERRIDE  
 3 = PUSH PIN  
 4 = PUSH BOTTON  
 5 = HEX. ALLEN

CONNECTOR TYPE

0 = WITHOUT COIL  
 C = CAVI / LEADS  
 D = DIN 43650  
 G = DEUTSCH DT04-2P  
 A = AMP JUNIOR

TENSIONE / VOLTAGE

000 = WITHOUT COIL  
 D12 = 12 VDC  
 D24 = 24 VDC  
 220 = 220 RAC

\*see *CARTDRIGE VALVES* catalog

WWW.GPA.BY

ELEMENTO DI COLLEGAMENTO PER E\_06-13-12/E\_06-13-38/E\_06-25-38  
 SINGLE SUBPLATE FOR E\_06-13-12/E\_06-13-38/E\_06-25-38

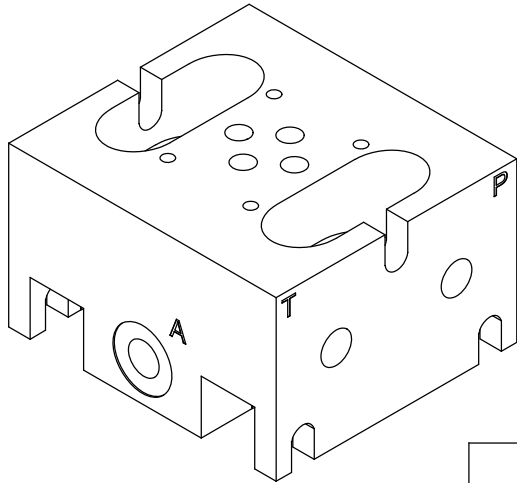

Schema idraulico  
Hydraulic diagram

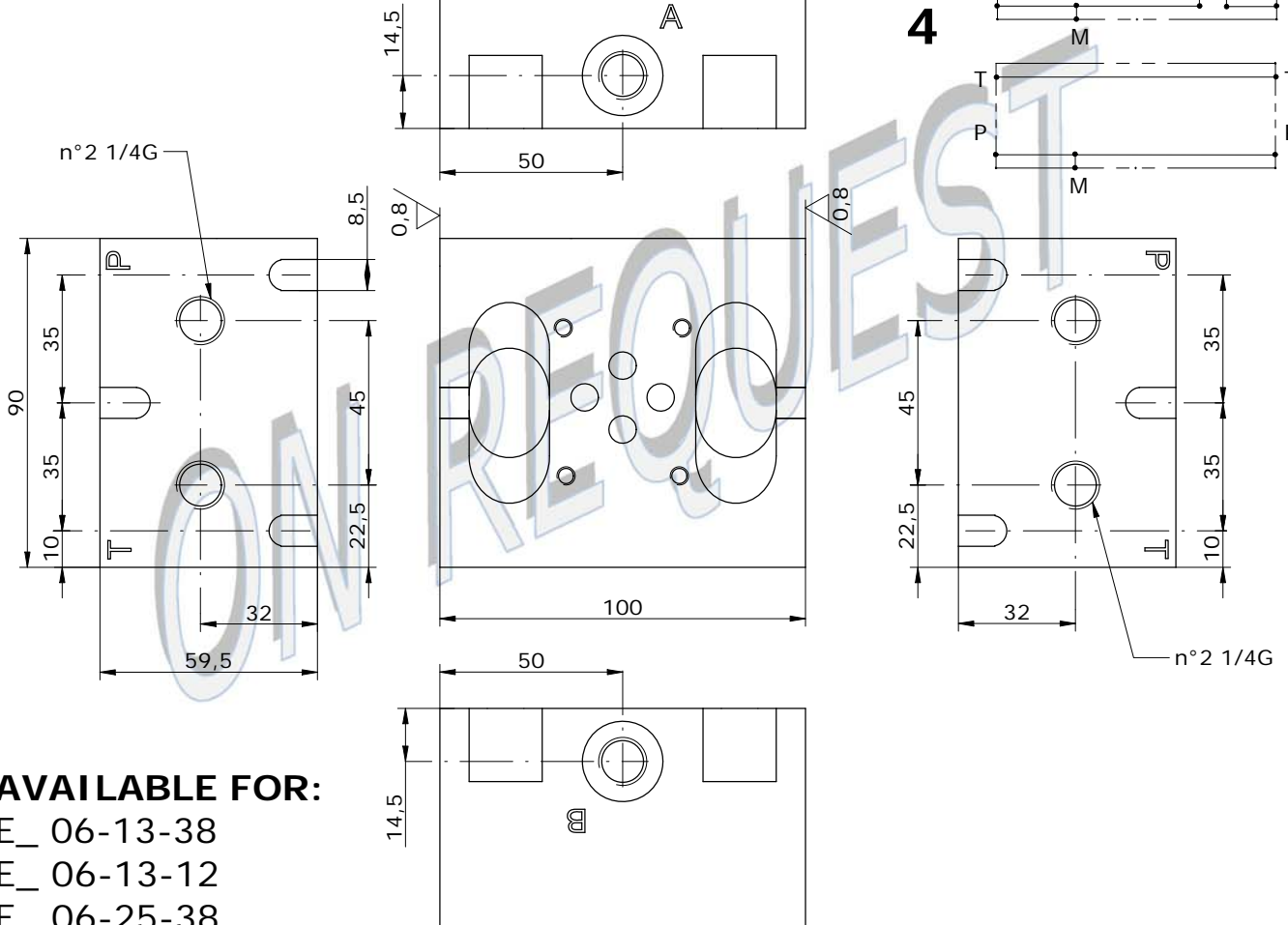
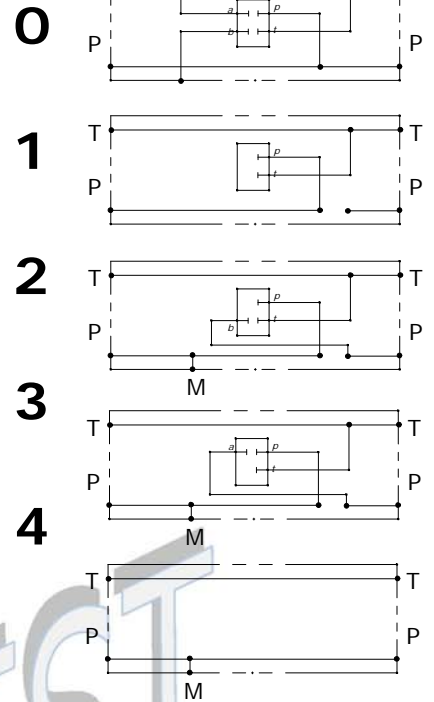

AVAILABLE FOR:

- E\_06-13-38
- E\_06-13-12
- E\_06-25-38

**E\_06 - 11 -** \_\_\_\_\_

**S** = STEEL  
**A** = ALUMINUM

SEE SCHEME

(A-B PORTS)  
**14** = 1/4"G  
**38** = 3/8"G

**MONOBLOCCO A-B POSTERIORI 1/2" P-T 1/2" PREDISP. PER ELEM. MODULARI**  
**MONOBLOCK A-B BACK 1/2" P-T 1/2" BSP ARRANGED FOR MODULAR PANELS**

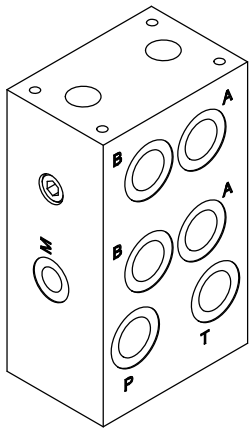

Schema idraulico  
Hydraulic diagram

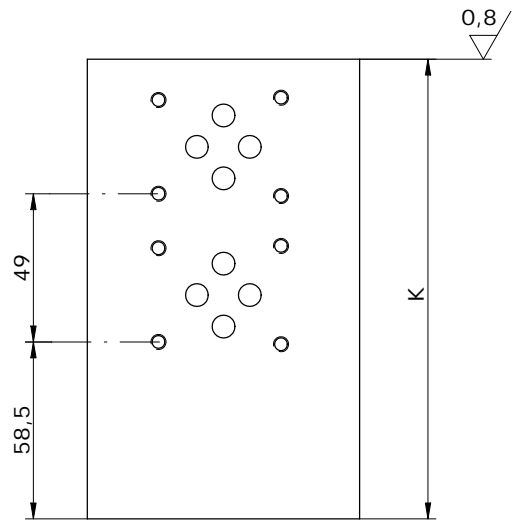
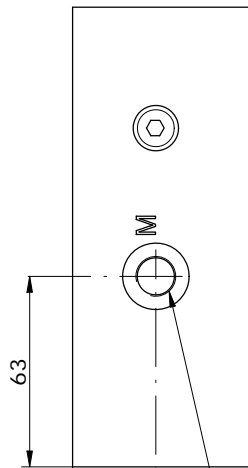
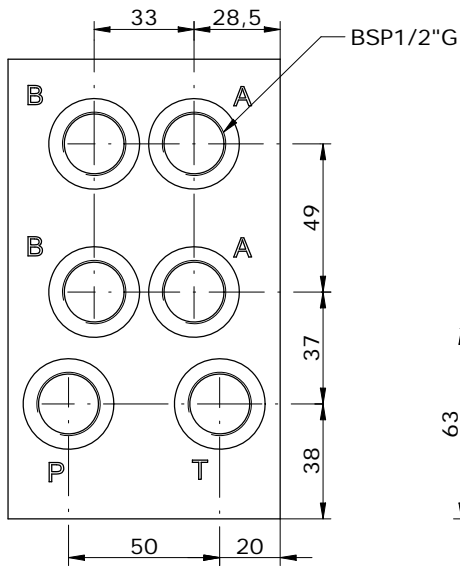
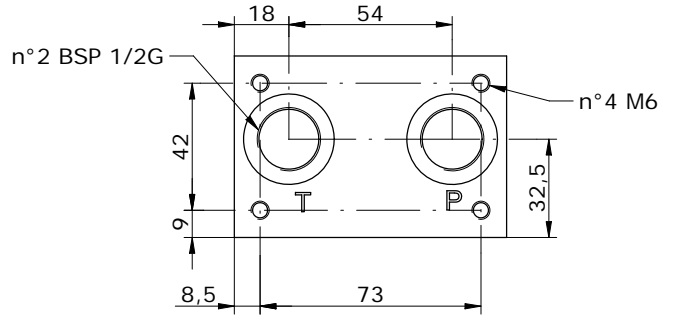
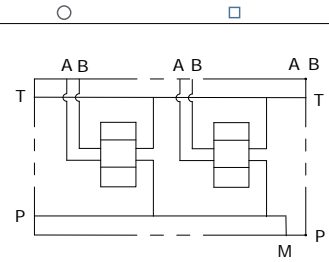

Predisposizione per pannelli modulari tipo E\_ 610 (vedi sezione el. modulari)  
 Arranged for modular panels E\_ 610 series. (see modular element section)

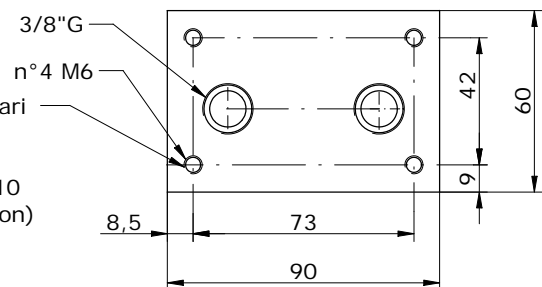

**E\_ 06 - 18 - 12 - \_\_\_ - 1**

POS.	02	04	06	08
K	152	250	348	446

**MONOBLOCCO A-B POSTERIORI 1/2" P-T 1/2" PREDISP. PER ELEM. MODULARI**  
**MONOBLOCK A-B BACK 1/2" P-T 1/2" BSP ARRANGED FOR MODULAR PANELS**

**E\_06 - 18 - 12 - \_\_\_ - 1**

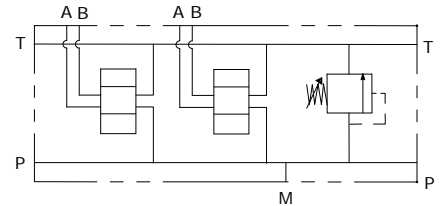
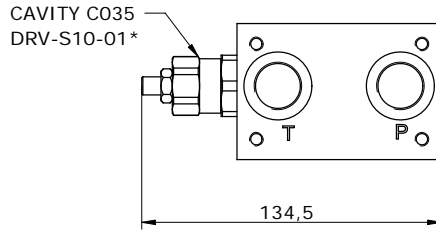
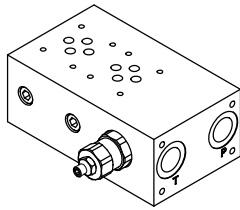

**E\_06 - 18 - 12 - \_\_\_ - 2**

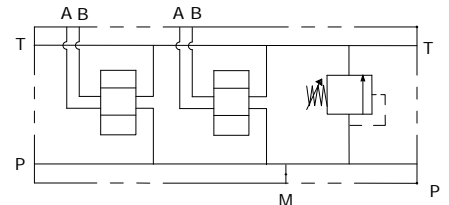
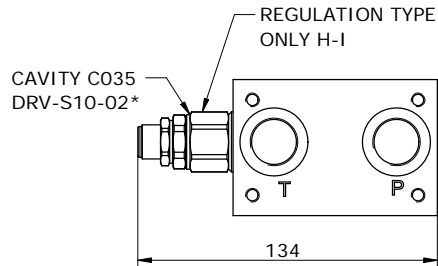
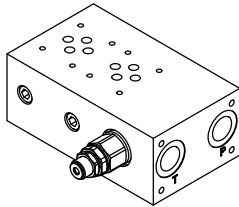

**E\_06 - 18 - 12 - \_\_\_ - 3**

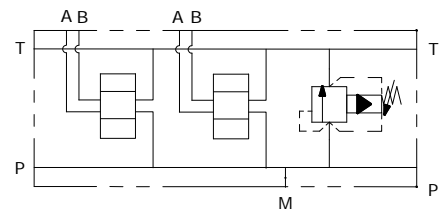
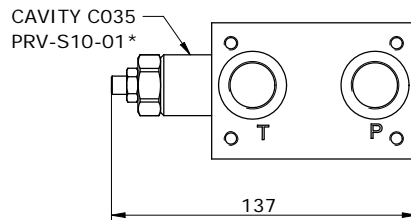
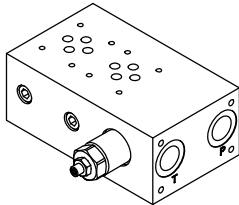

**E\_06 - 18 - 12 - \_\_\_ - 4**

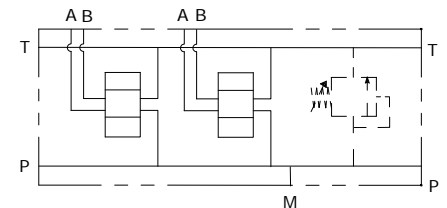
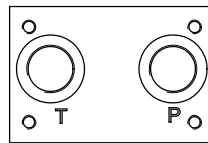
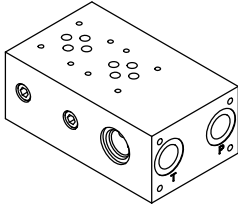

**TIPDI REGOLAZIONE PER V. MAX**  
**REGULATION TYPE FOR RELIEF VALVE**

	<b>H</b> VITE CON CHIAVE ESAGONALE (standard) HEXAGONAL HEAD SCREW
	<b>K</b> POMOLO KNOB
	<b>C</b> FISSA CON CAPPUCCIO COVER CAP
	<b>I</b> INVIOLABILE

**\* PER LA DRV-S10-02 SONO DISPONIBILE SOLO LA VERSIONE "H" E "I".  
 FOR DRV-S10-02 IS ONLY AVAILABLE "H" AND "I" VERSIONS.**

**E\_06 - 18 - 12 - \_\_\_ - \_\_\_ - \_\_\_ - \_\_\_ - \_\_\_ - \_\_\_**

**S = STEEL**  
**A = ALUMINUM**

**MOUNTING POSITIONS: 02 ÷ 08**

- 0 = WITHOUT RELIEF VALVE**
- 1 = WITH DIRECT R.V. - DRV-S10-01**
- 2 = WITH DIRECT R.V. - DRV-S10-02**
- 3 = WITH PILOT R.V. - PRV-S10-01**
- 4 = RELIEF VALVE READY**

**OMETTERE / OMIT**  
**H = HEXAGONAL HEAD SCREW**  
**K = KNOB**  
**C = COVER CAP**  
**I = NOT ADJUSTABLE**

DIRECT R.V. - DRV-S10-01	DIRECT R.V. - DRV-S10-02	PILOT R.V. - PRV-S10-01
<b>0 = WITHOUT</b>	<b>0 = WITHOUT</b>	<b>0 = WITHOUT</b>
<b>1 = 0-80 bar</b>	<b>1 = 5-75 bar</b>	<b>1 = up to 140 bar</b>
<b>2 = 50-190 bar</b>	<b>2 = 75-125 bar</b>	<b>2 = up to 280 bar</b>
<b>3 = 100-350</b>	<b>3 = 125-220 bar</b>	<b>3 = up to 420 bar</b>
	<b>4 = 220-350 bar</b>	

\*see **CARTDRIGE VALVES** catalog

**BASE SINGOLA CETOP 06 R CON UTILIZZI P-T-X POSTERIORI  
 PER REGOLATORE DI PRESSIONE  
 SUB - PLATE CETOP 06 R WITH P-T-X PORTS BACK FOR RELIEF VALVE**

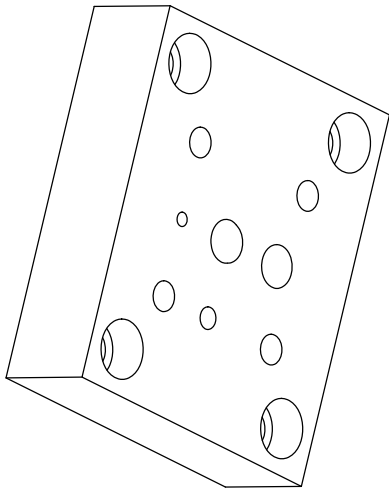

Schema idraulico  
 Hydraulic diagram

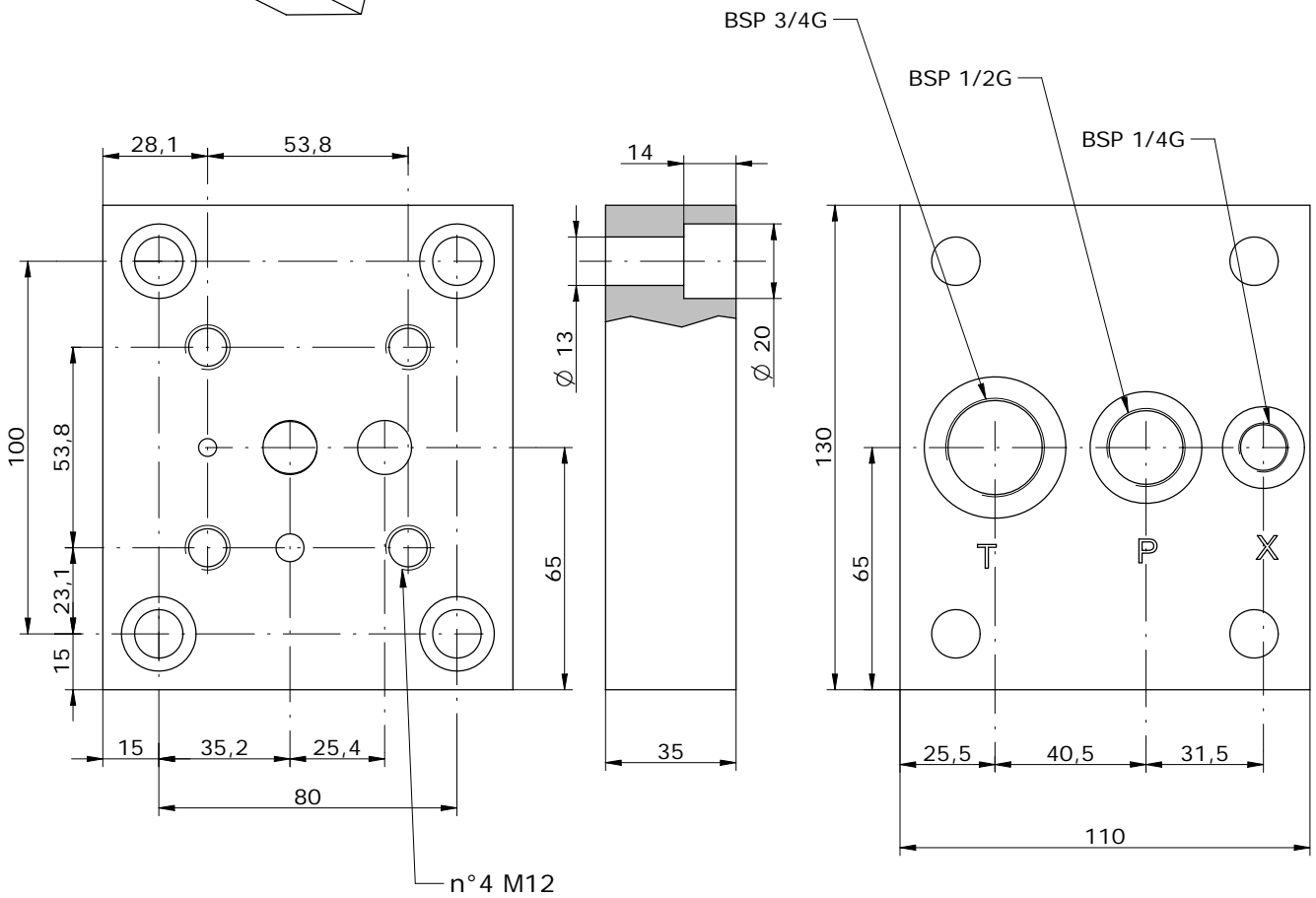
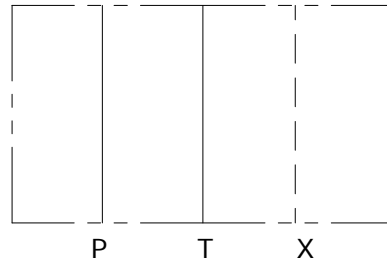

**E\_ R06 - 32 - 12**

**S** = STEEL  
**A** = ALUMINUM (ON REQUEST)

BASE ISO/CETOP 08R. P-T DA 1" G. ISO 6264-08-13-1-97 PER REGOLATORE  
 DI PRESSIONE  
 SUB-PLATE ISO/CETOP 08R. P-T DA 1" G. ISO 6264-08-13-1-97  
 FOR RELIEF VALVE

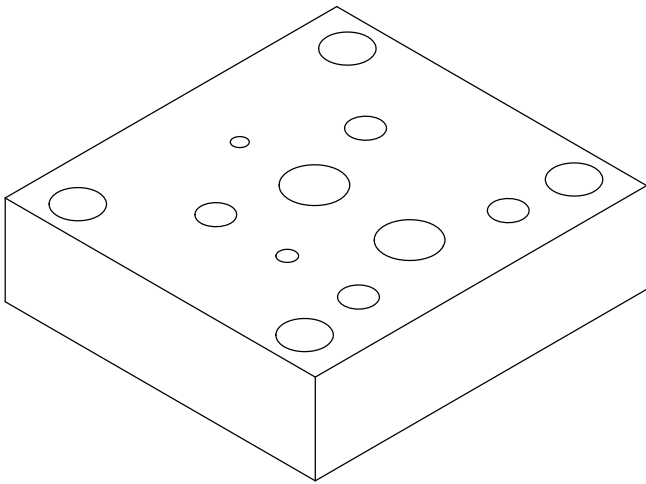
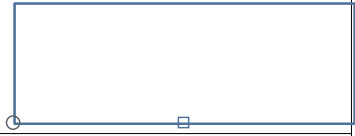

SCHEMA IDRAULICO  
 HYDRAULIC DIAGRAM

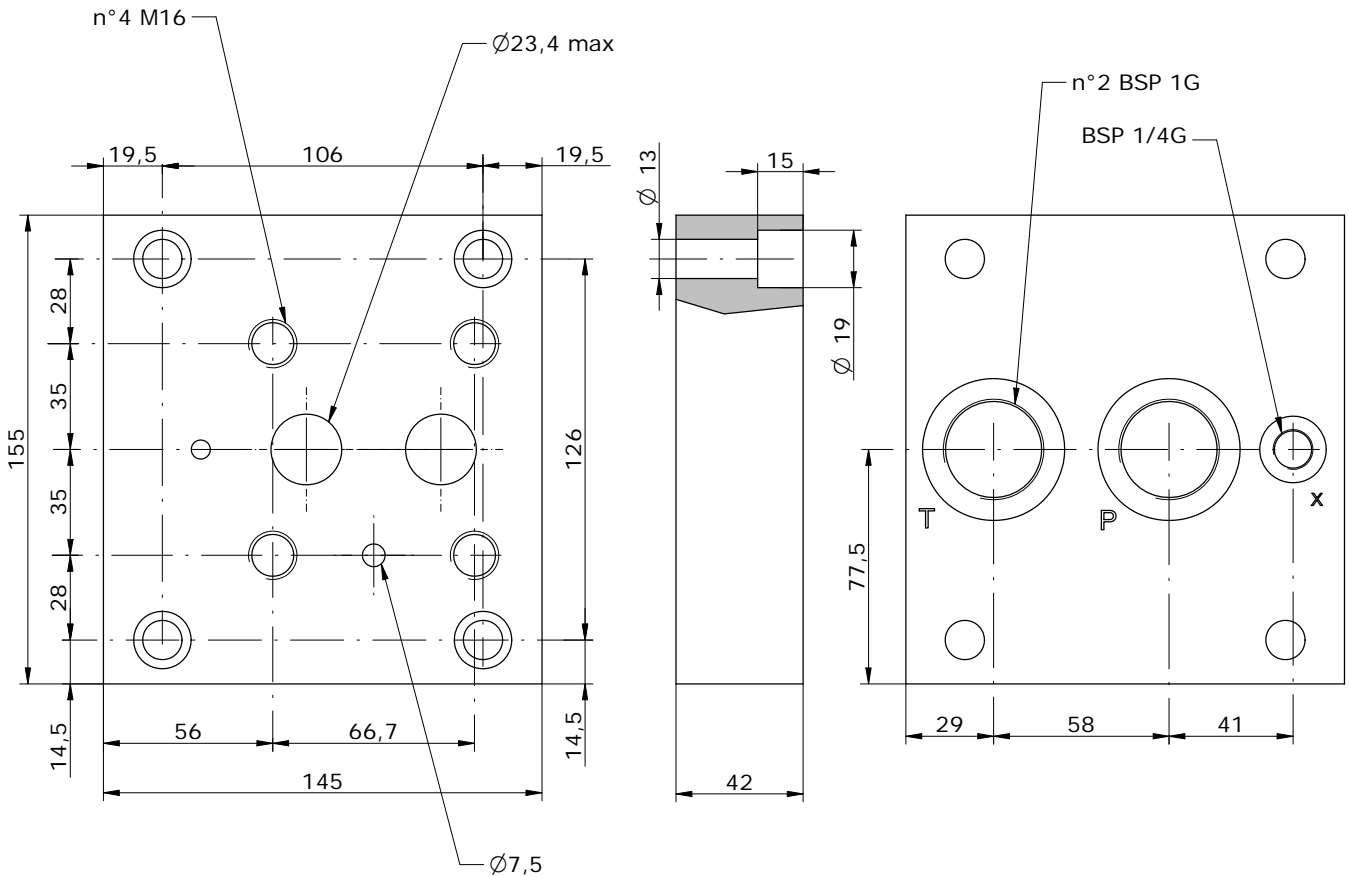
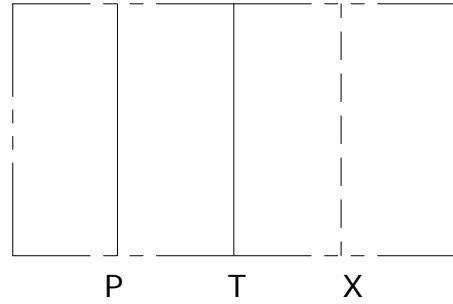

# E\_R08 - 35 - 100

**S** = STEEL  
**A** = ALUMINUM (ON REQUEST)

**BASE DI COLLEGAMENTO ISO/CETOP 10R PER REGOLATORE DI PRESSIONE**  
**SUB-PLATE ISO/CETOP 10R FOR RELIEF VALVE**

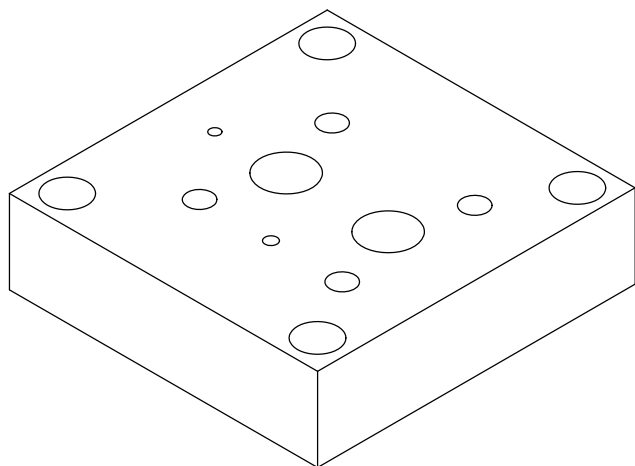

Schema Idraulico  
Hydraulic diagram

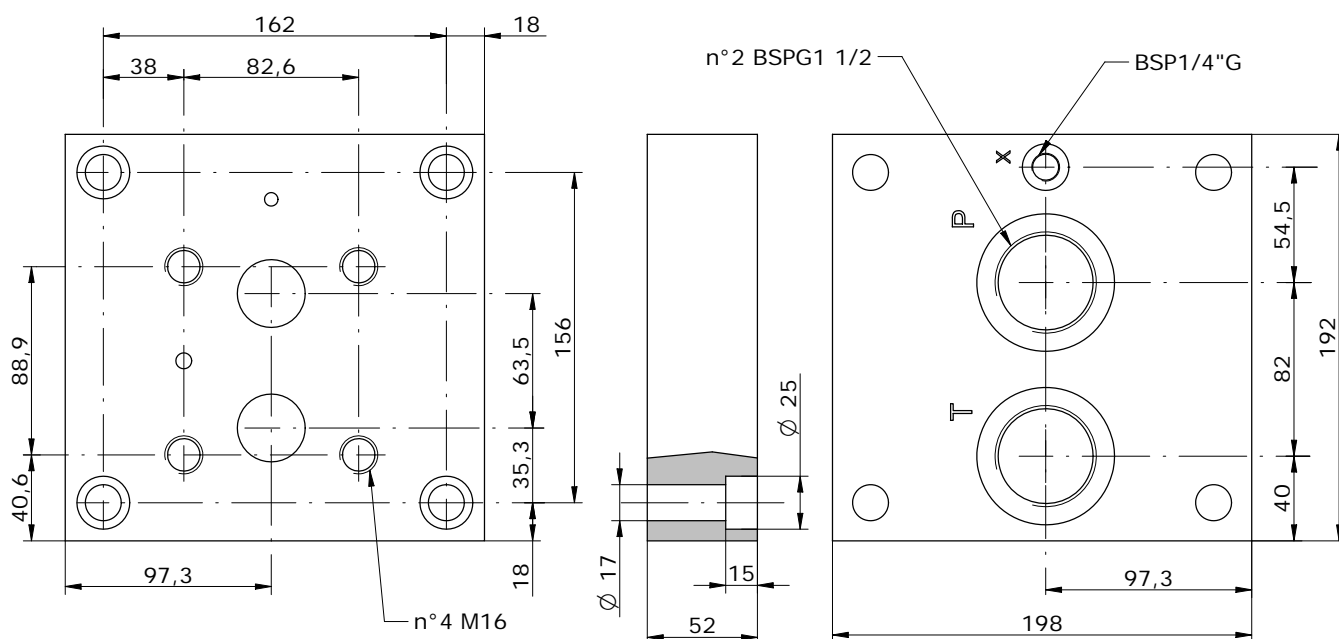
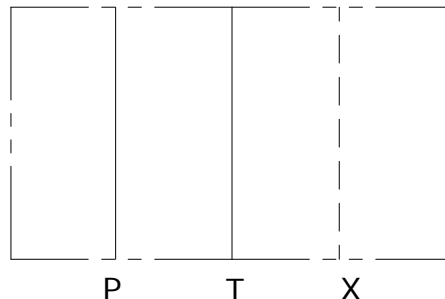

# E\_R10 - 37 - 112

**S = STEEL**  
**A = ALUMINIUM**



---

***Note - Notes***

A series of 25 horizontal dashed lines for writing notes.



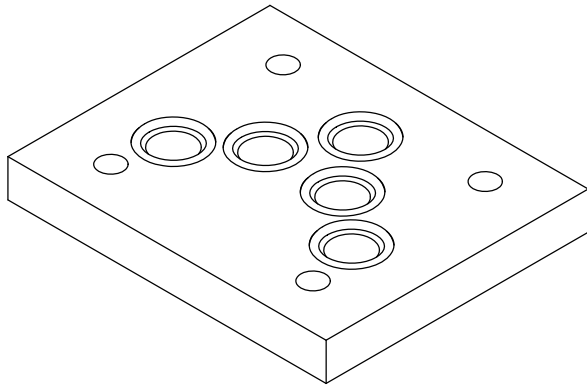

Schema idraulico  
Hydraulic diagram

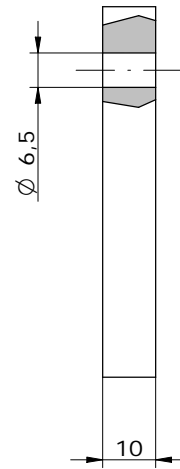
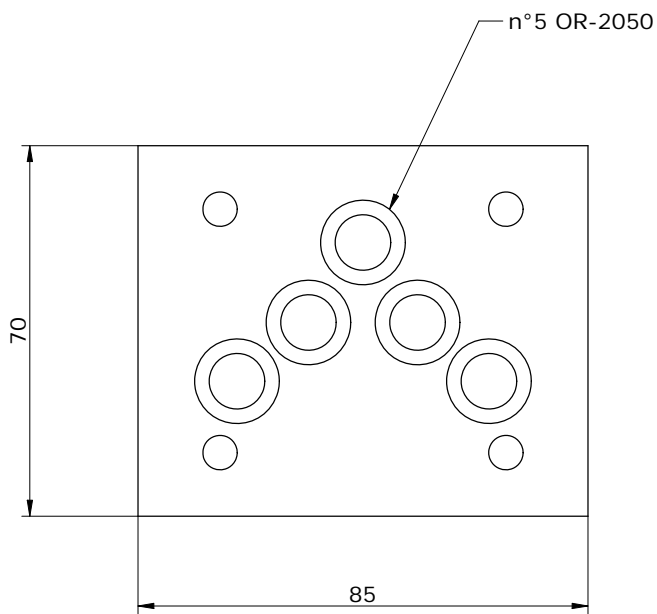

**E\_ 10 - 00 - 10**

**S = STEEL**

**BASE DI CHIUSURA - COLLEGAMENTO CETOP 5**  
**END - SUB - PLATE CETOP 5**

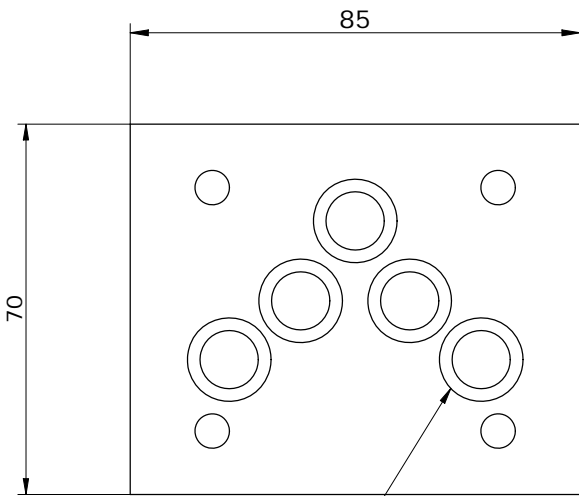
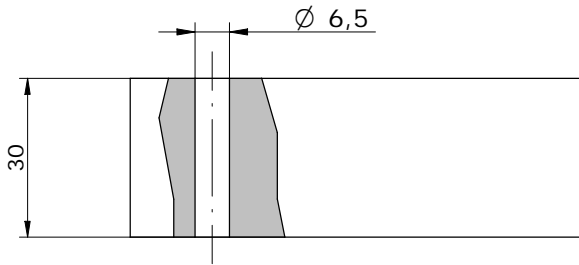
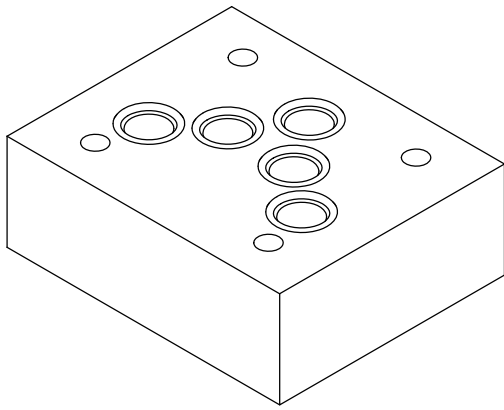
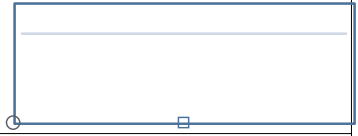

N°5 OR-2050

Schema idraulico  
 Hydraulic diagram

**0**

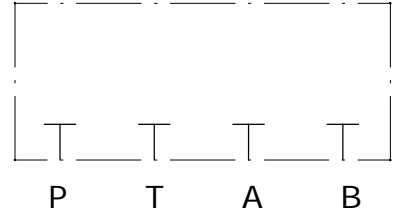

**1**

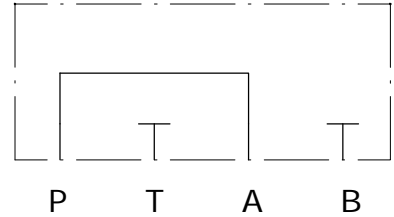

**2**

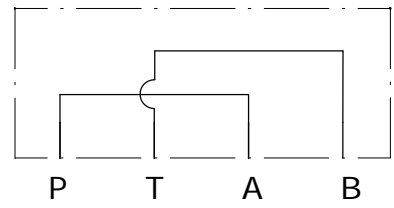

**3**

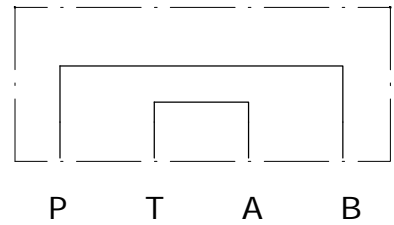

**4**

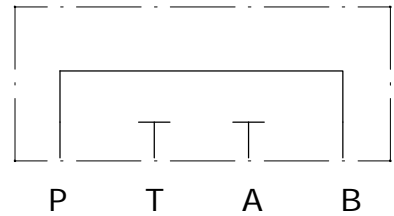

**E\_ 10 - 00 - 20 - \_**

**S** = STEEL  
**A** = ALUMINUM

SEE DIAGRAMS

**BASE DI COLLEGAMENTO CETOP 5 CON ATTACCHI BSP  
END SUB-PLATE CETOP 5 WITH BSP PORTS**

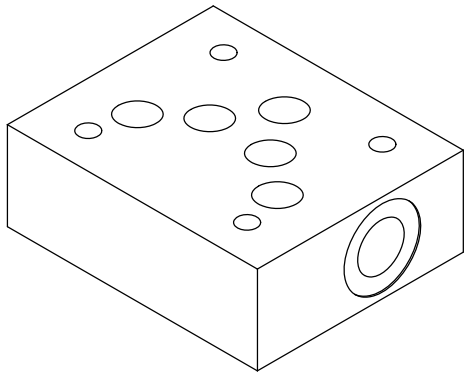

COD.	DIAGRAMS	
	1	<b>A+B</b>
2	<b>A</b>	ON REQUEST
3	<b>B</b>	ON REQUEST
4	<b>P+T</b>	STANDARD
5	<b>P</b>	ON REQUEST
6	<b>T</b>	ON REQUEST
7	<b>P+P</b>	ON REQUEST
8	<b>T+T</b>	ON REQUEST

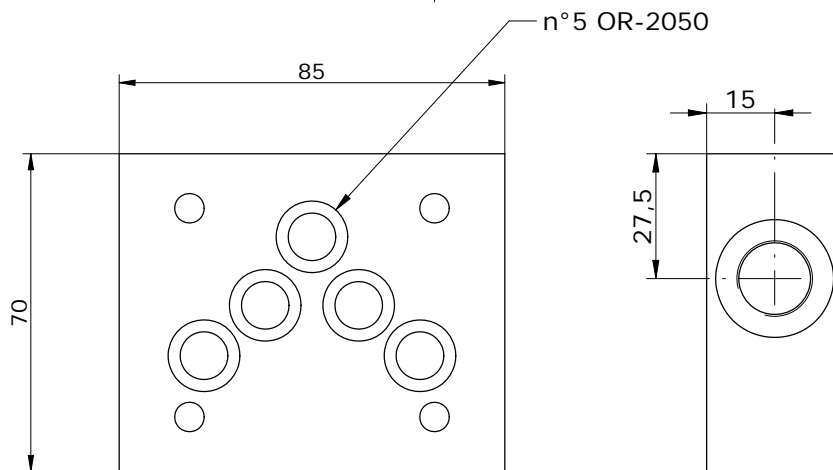
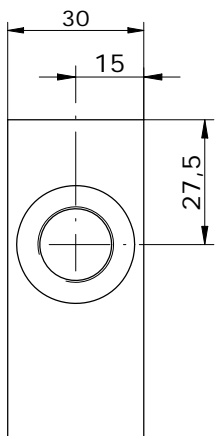
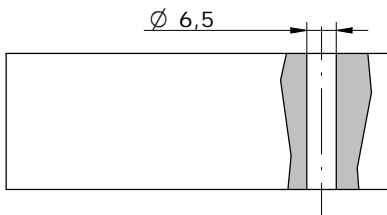
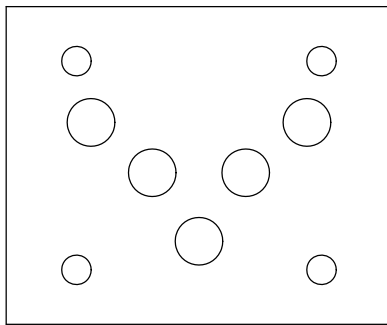

**E\_ 10 - 10 - \_ - \_**

**S** = STEEL  
**A** = ALUMINUM

SEE DIAGRAMS

**14** = BSP 1/4G  
**38** = BSP 3/8G

**PANNELLO MODULARE CETOP 5 PER PRESSOSTATO**  
**PACKING PLATE CETOP 5 FOR PRESSURE SWITCH**

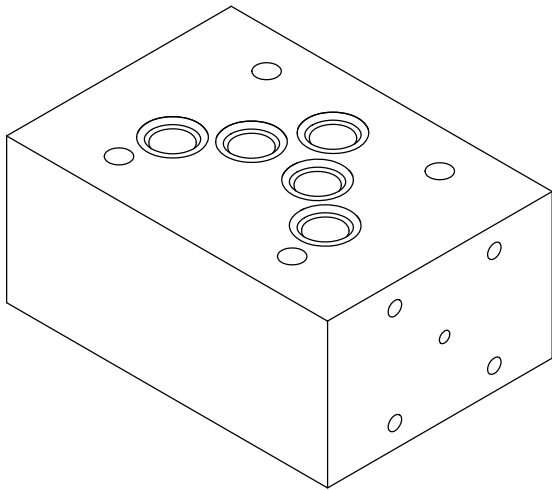

CODE	DIAGRAMS	
1	A+B	standard
2	A	standard
3	B	standard
4	P+T	on request
5	P	on request
6	T	on request
7	P+P	on request

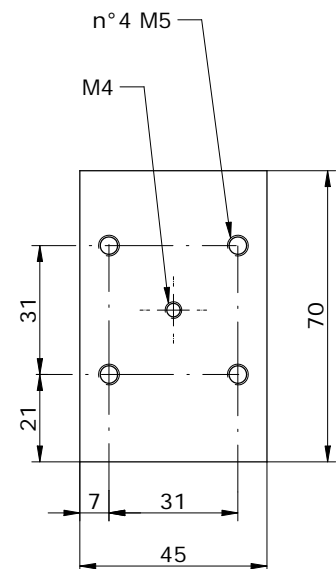
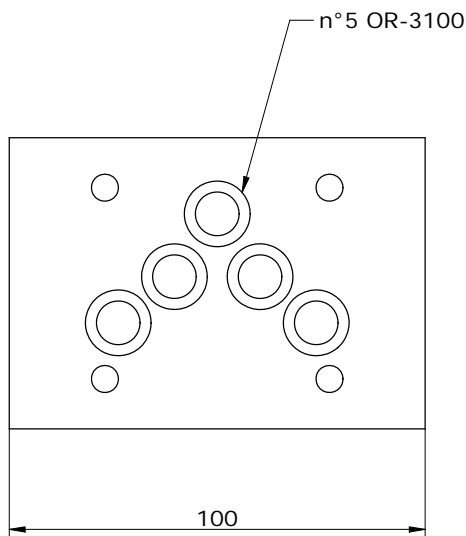
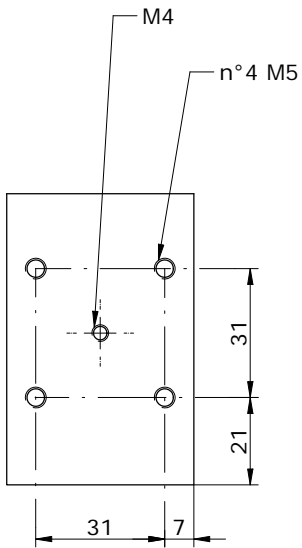
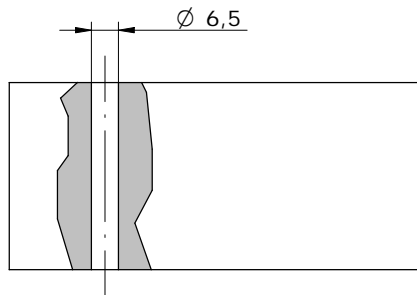

**E\_ 610 - 10 - \_**

S = STEEL  
 A = ALUMINUM

SEE DIAGRAMS

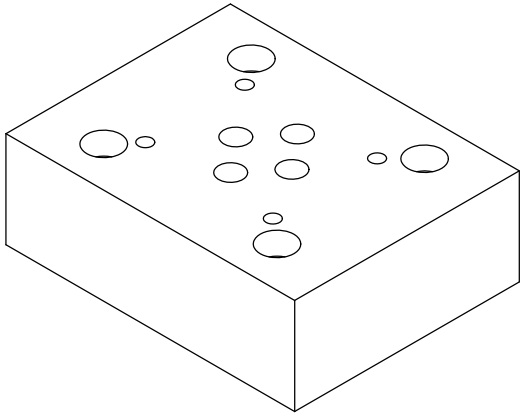

Schema idraulico  
 Hydraulic diagram

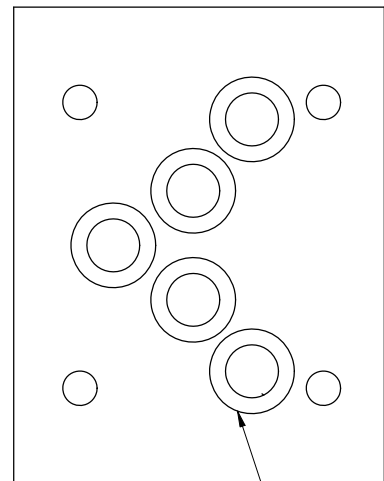
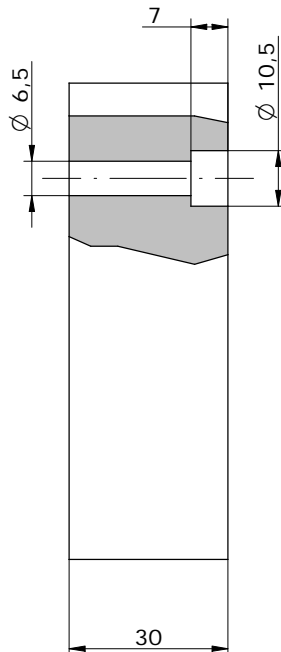
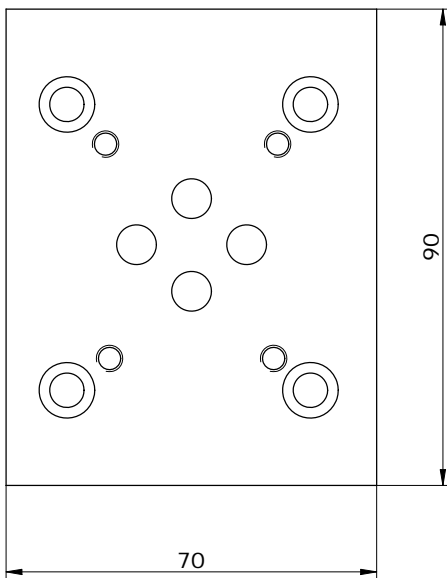
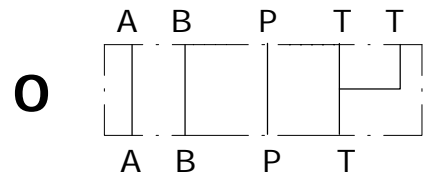
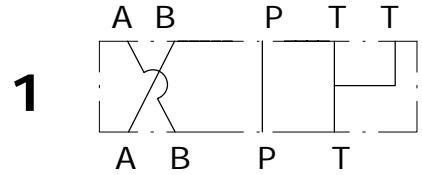

n°5 OR-2050

**E\_ 610 - 05 -**

**S** = STEEL  
**A** = ALUMINUM

SEE DIAGRAMS

**BASE SINGOLA CETOP 5 CON UTILIZZI A-B-P-T LATERALI**  
**SUB-PLATE CETOP 5 WITH A-B-P-T PORTS ON SIDE**

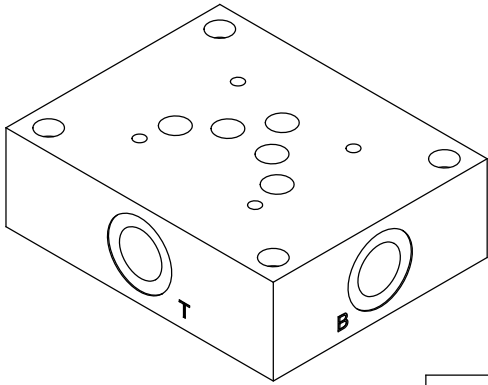

Schema idraulico  
Hydraulic diagram

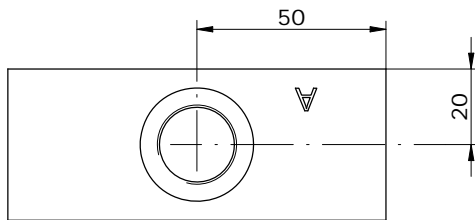
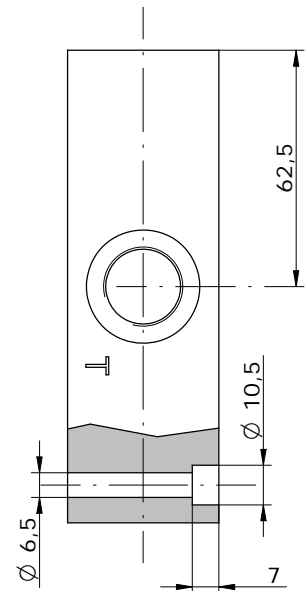
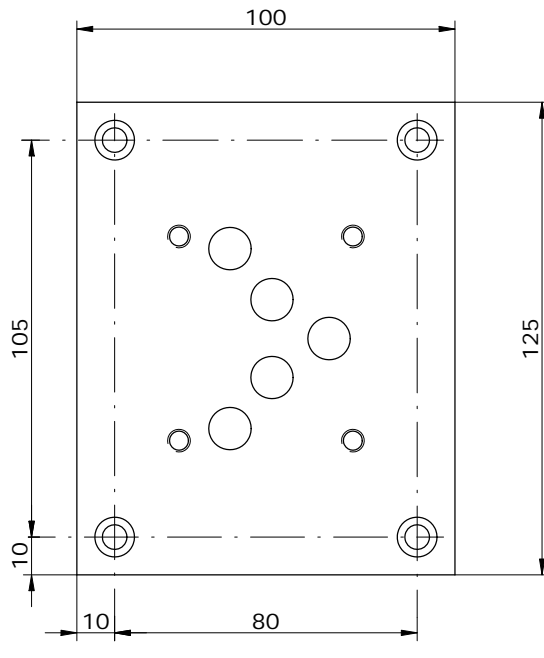
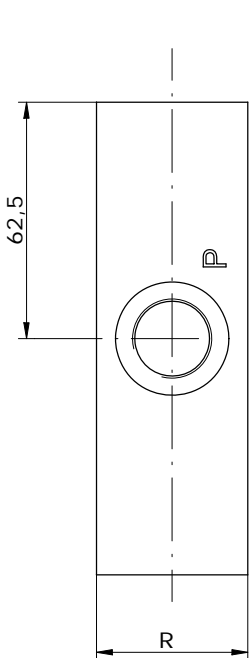
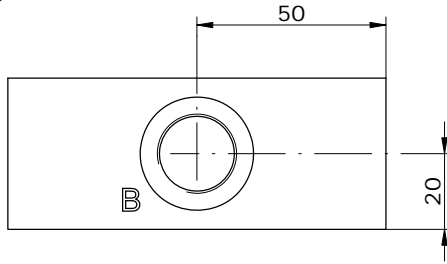
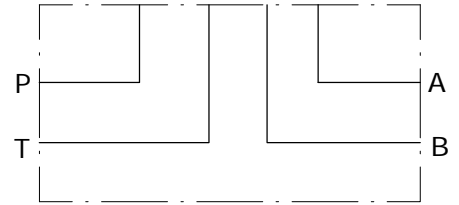

VERSION	R
E_10-02-12	40
E_10-02-34	50

**E\_ 10 - 02 -**

**S** = STEEL  
**A** = ALUMINUM

**12** = BSP 1/2G  
**34** = BSP 3/4G



**BASE SINGOLA CETOP 5 CON UTILIZZI A-B LAT. P-T POST.  
SUB-PLATE CETOP 5 WITH A-B PORTS ON SIDE P-T BACK**

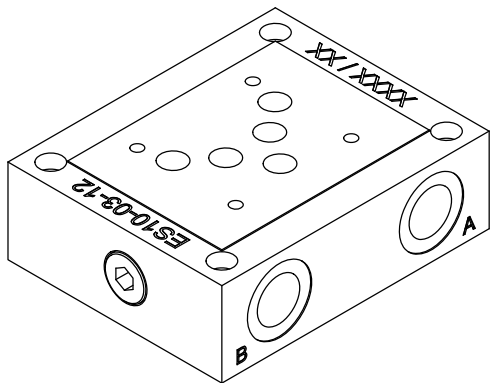

Schema idraulico  
Hydraulic diagram

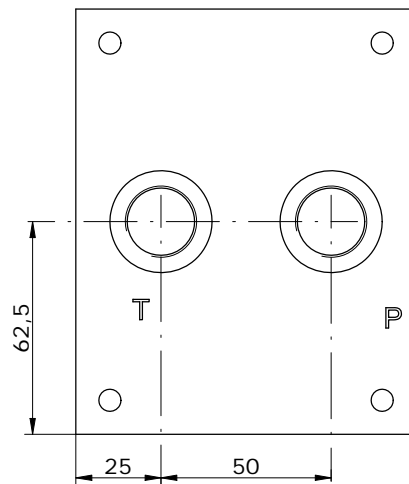
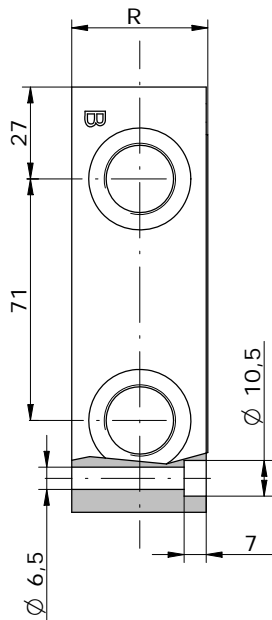
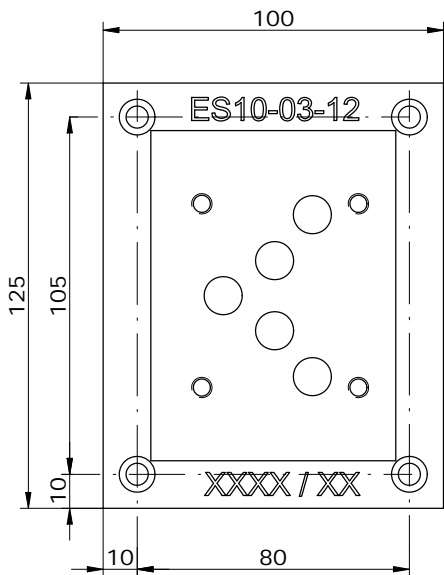
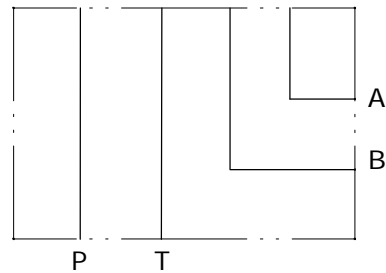

**OPTIONAL:**  
FITTING FOR GAUGE AND  
PRESSURE SWITCH

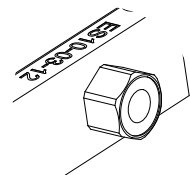

**FG14**

VERSION	R
E_10-03-12	40
E_10-03-34	45

**E\_ 10 - 03 -** \_\_\_\_\_

**S** = STEEL  
**A** = ALUMINUM

**12** = BSP 1/2G  
**34** = BSP 3/4G

**BASE SINGOLA CETOP 5 CON UTILIZZI A-B LAT. P-T POST.  
SUB-PLATE CETOP 5 WITH A-B PORTS ON SIDE P-T BACK**

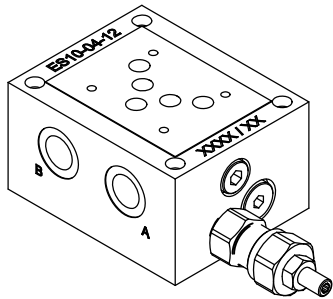
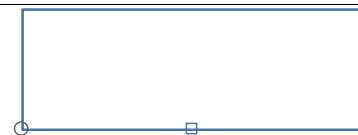

Schema idraulico  
Hydraulic diagram

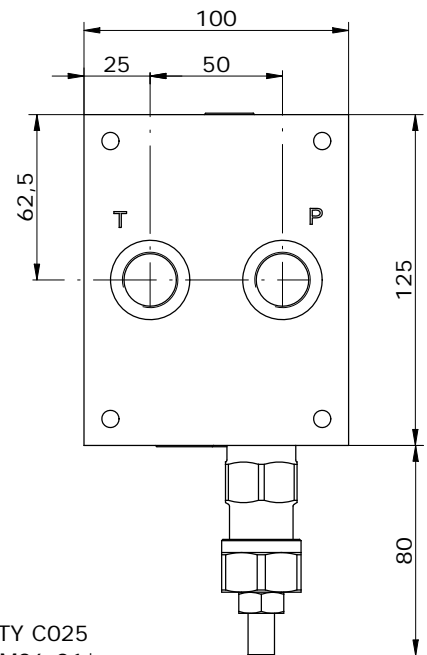
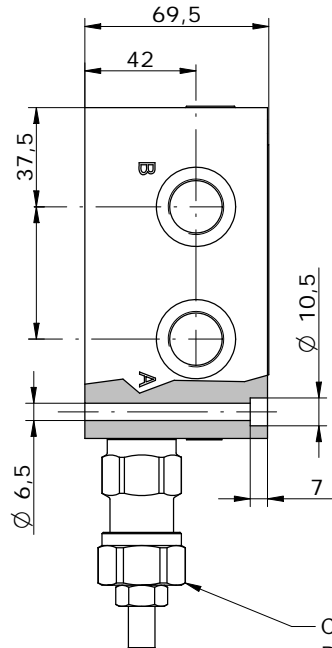
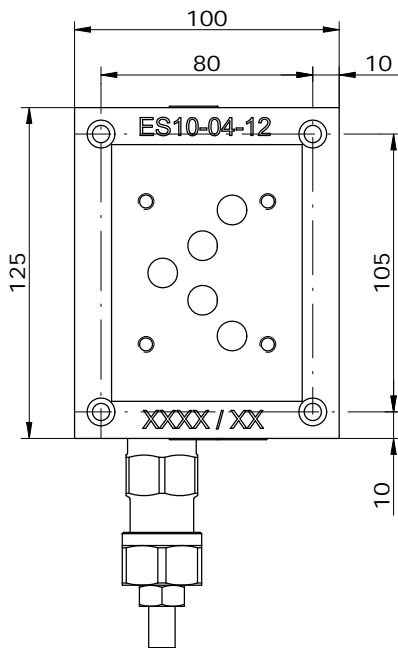
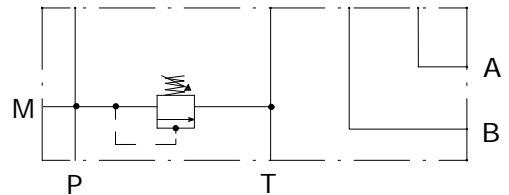

**TIPI DI REGOLAZIONE  
REGULATION TYPE**

	<b>H</b> VITE CON CHIAVE ESAGONALE (standard) HEXAGONAL HEAD SCREW
	<b>K</b> POMOLO KNOB
	<b>C</b> FISSA CON CAPPUCCIO COVER CAP
	<b>I</b> INVIOLABILE

**OPTIONAL  
FITTING FOR GAUGE AND  
PRESSURE SWITCH**

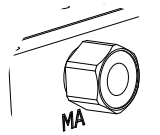

**FG14**

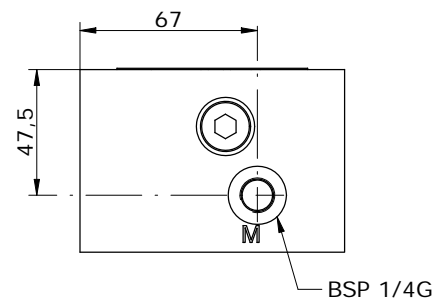

**E\_ 10 - 04 - - - - -**

**S** = STEEL  
**A** = ALUMINUM

**12** = BSP 1/2G  
**34** = BSP 3/4G

**0** = WITHOUT RELIEF VALVE  
**1** = WITH RELIEF VALVE  
**2** = RELIEF VALVE READY

**OMETTERE / OMIT**  
**H** = HEXAGONAL HEAD SCREW  
**K** = KNOB  
**C** = COVER CAP  
**I** = NOT ADJUSTABLE

**0** = WITHOUT RELIEF VALVE  
**1** = 5-55 BAR  
**2** = 25-110 BAR  
**3** = 75-250 BAR

\*see **CARTDRIGE VALVES** catalog

**BASE SINGOLA CETOP 5 CON UTILIZZI A-B-P-T LATERALI**  
**SUB-PLATE CETOP 5 WITH A-B-P-T PORTS ON SIDE**

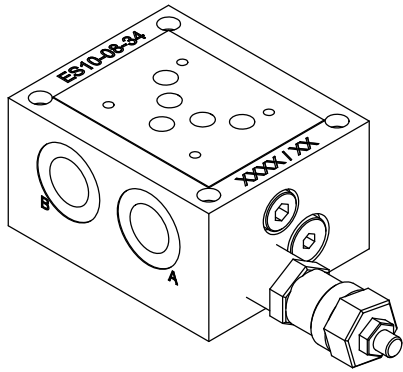

Schema idraulico  
Hydraulic diagram

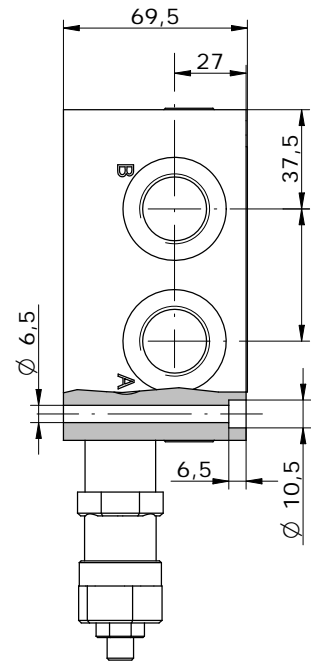
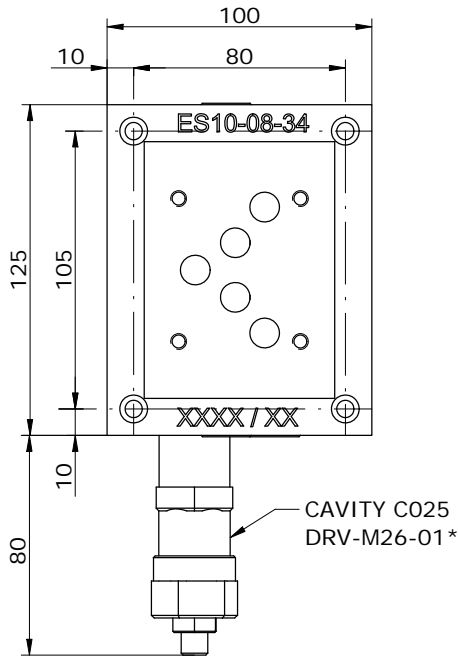
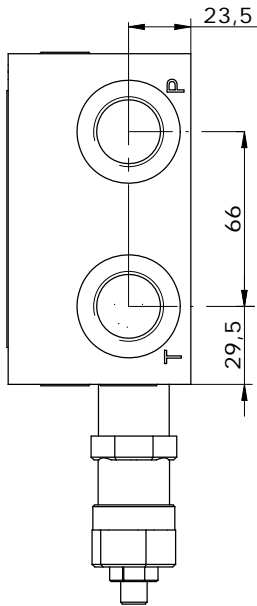
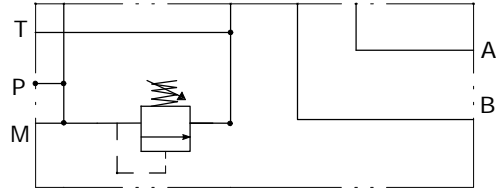

**TIPI DI REGOLAZIONE**  
**REGULATION TYPE**

	<b>H</b> VITE CON CHIAVE ESAGONALE (standard) <i>HEXAGONAL HEAD SCREW</i>
	<b>K</b> POMOLO <i>KNOB</i>
	<b>C</b> FISSA CON CAPPUCCIO <i>COVER CAP</i>
	<b>I</b> INVIOLABILE

**OPTIONAL**  
**FITTING FOR GAUGE AND**  
**PRESSURE SWITCH**

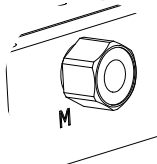

**FG14**

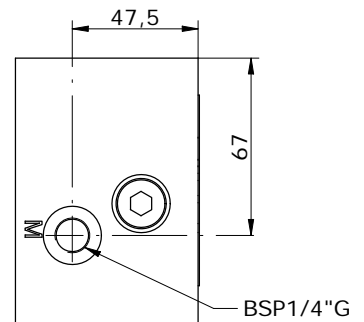

**E\_ 10 - 08 - - - - -**

**S** = STEEL  
**A** = ALUMINUM

**12** = BSP 1/2G  
**34** = BSP 3/4G

**0** = WITHOUT RELIEF VALVE  
**1** = WITH RELIEF VALVE  
**2** = RELIEF VALVE READY

**OMETTERE / OMIT**  
**H** = HEXAGONAL HEAD SCREW  
**K** = KNOB  
**C** = COVER CAP  
**I** = NOT ADJUSTABLE

**0** = WITHOUT RELIEF VALVE  
**1** = 5-55 BAR  
**2** = 25-110 BAR  
**3** = 75-250 BAR

\* see **CARTDRIGE VALVES** catalog

WWW.GPA.BY

**BASE SINGOLA CETOP 5 CON UTILIZZI A-B-P-T LATERALI, P-T POSTERIORI**  
**SUB-PLATE CETOP 5 WITH A-B-P-T PORTS ON SIDE, P-T BACK**

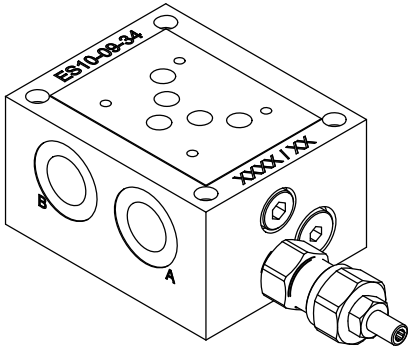

Schema idraulico  
Hydraulic diagram

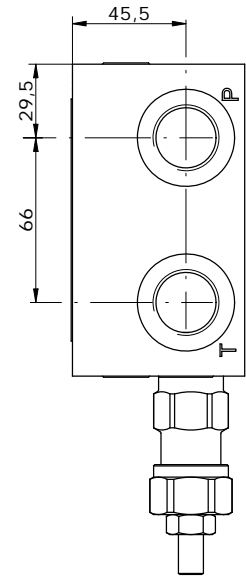
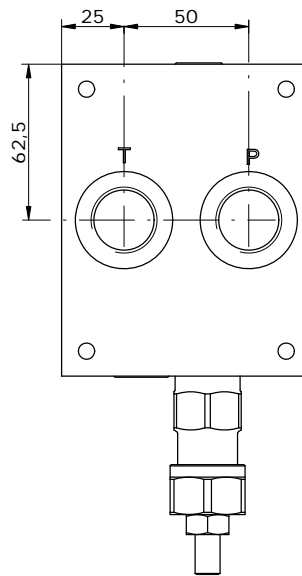
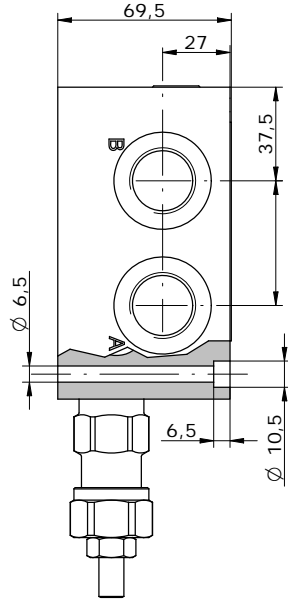
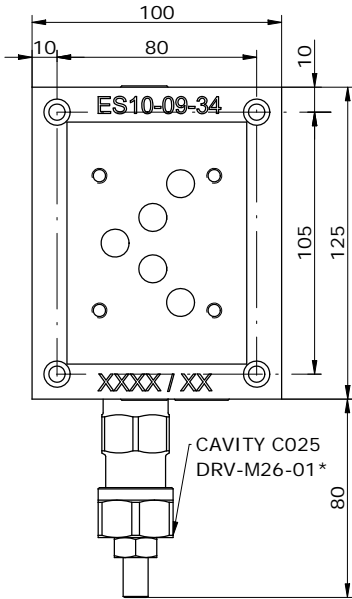
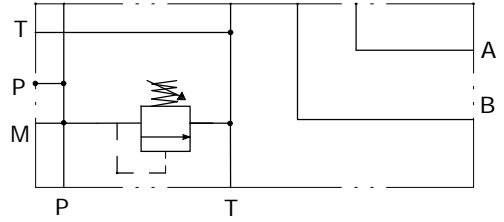

**TIPI DI REGOLAZIONE**  
**REGULATION TYPE**

	<b>H</b>	VITE CON CHIAVE ESAGONALE (standard) HEXAGONAL HEAD SCREW
	<b>K</b>	POMOLO KNOB
	<b>C</b>	FISSA CON CAPPUCCIO COVER CAP
	<b>I</b>	INVIOLABILE

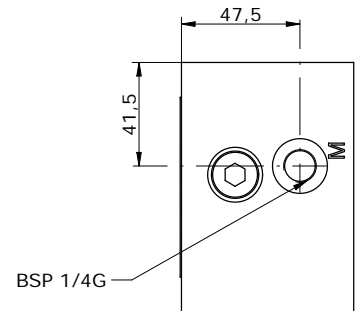
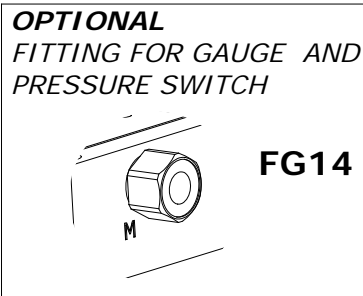

**E\_ 10 - 09 -** \_\_\_\_\_

**S** = STEEL  
**A** = ALUMINUM

**12** = BSP 1/2G  
**34** = BSP 3/4G

**0** = WITHOUT RELIEF VALVE  
**1** = WITH RELIEF VALVE  
**2** = RELIEF VALVE READY

**OMETTERE / OMIT**  
**H** = HEXAGONAL HEAD SCREW  
**K** = KNOB  
**C** = COVER CAP  
**I** = NOT ADJUSTABLE

**0** = WITHOUT RELIEF VALVE  
**1** = 5-55 BAR  
**2** = 25-110 BAR  
**3** = 75-250 BAR

\* see **CARTDRIGE VALVES** catalog

WWW.GPA.BY

**BASE SINGOLA CETOP 5 CON UTILIZZI A-B-P 1/2" T 3/4" LAT. , P-T POST.**  
**SUB-PLATE CETOP 5 WITH A-B-P 1/2" T 3/4" ON SIDE, P-T BACK**

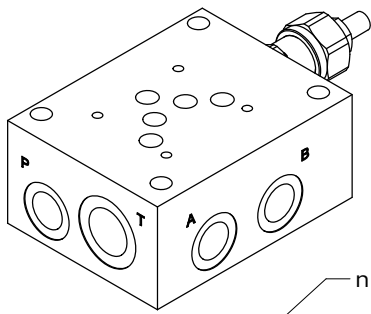

Schema idraulico  
Hydraulic diagram

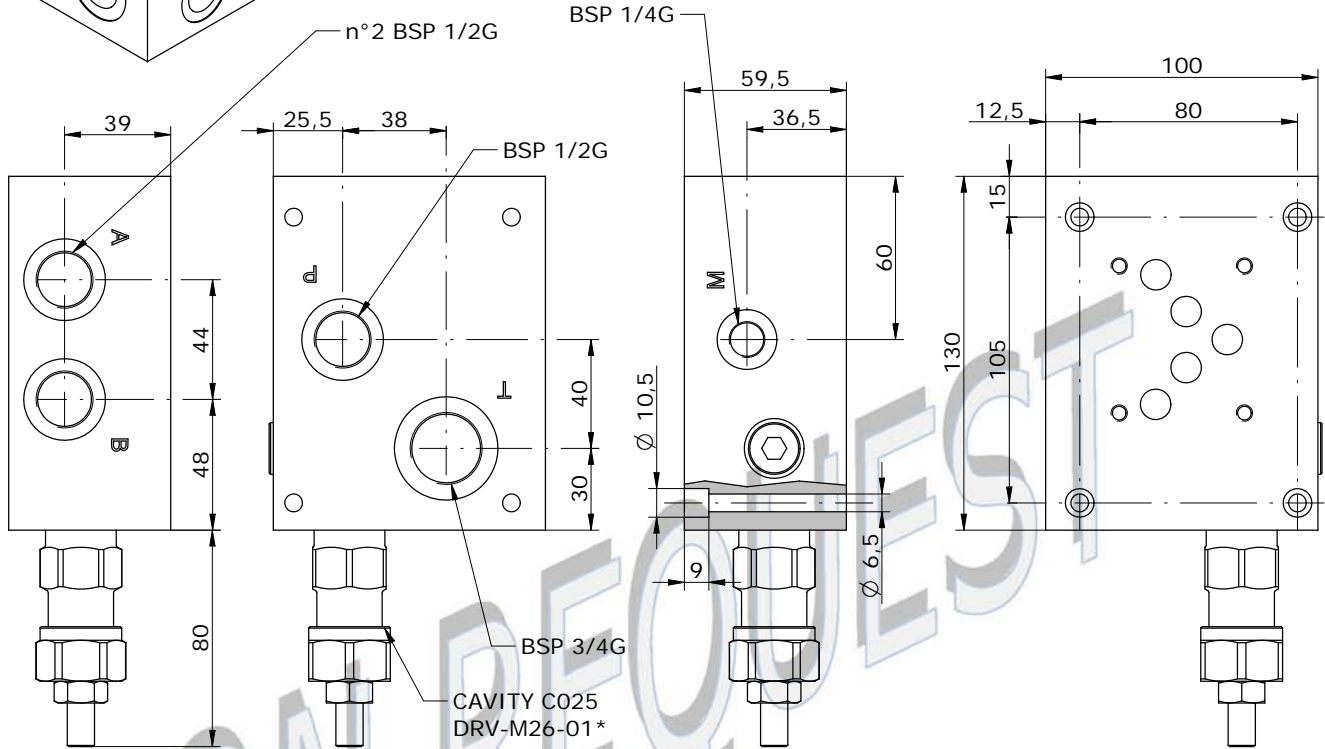
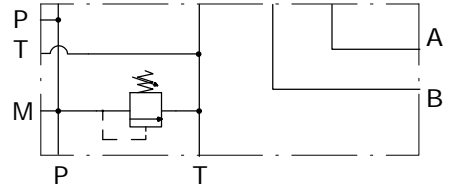

**TIPI DI REGOLAZIONE**  
**REGULATION TYPE**

	<b>H</b>	VITE CON CHIAVE ESAGONALE (standard) HEXAGONAL HEAD SCREW
	<b>K</b>	POMOLO KNOB
	<b>C</b>	FISSA CON CAPPuccio COVER CAP
	<b>I</b>	INVIOlabILE

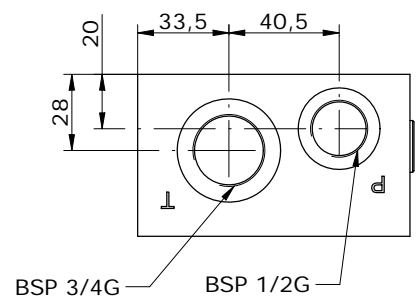

**E\_ 10 - 18 - 12 - - - -**

**S** = STEEL  
**A** = ALUMINUM

**0** = WITHOUT RELIEF VALVE  
**1** = WITH RELIEF VALVE  
**2** = RELIEF VALVE READY

**H** = HEXAGONAL HEAD SCREW  
**K** = KNOB  
**C** = COVER CAP  
**I** = NOT ADJUSTABLE

**0** = WITHOUT RELIEF VALVE  
**1** = 5-55 BAR  
**2** = 25-110 BAR  
**3** = 75-250 BAR

\*see **CARTDRIGE VALVES** catalog

WWW.GPA.BY

**MONOBLOCCO A-B POSTERIORI, P-T LATERALI 3/4"**  
**MONOBLOCK A-B BACK PORTS, P-T ON SIDE 3/4"**

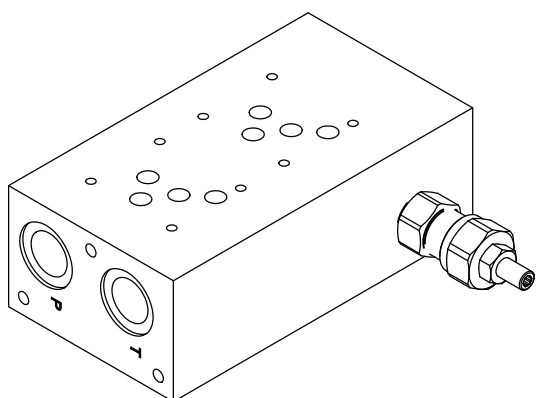

Schema idraulico  
Hydraulic diagram

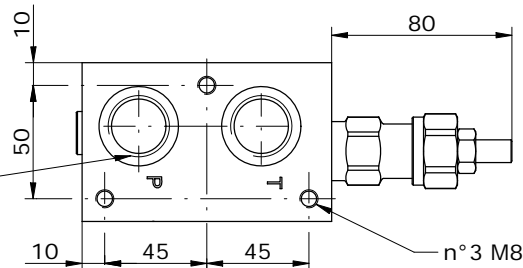
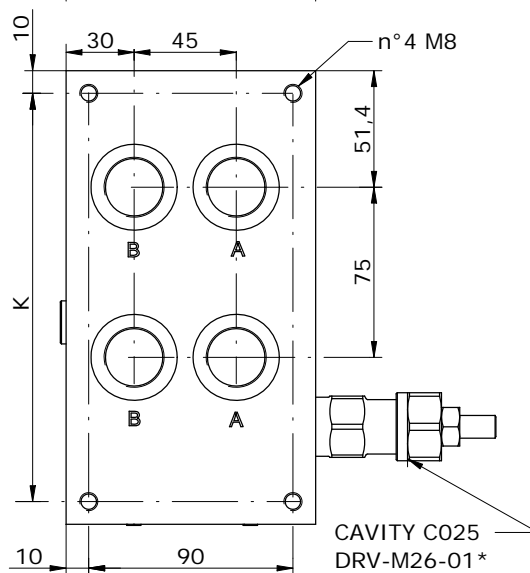
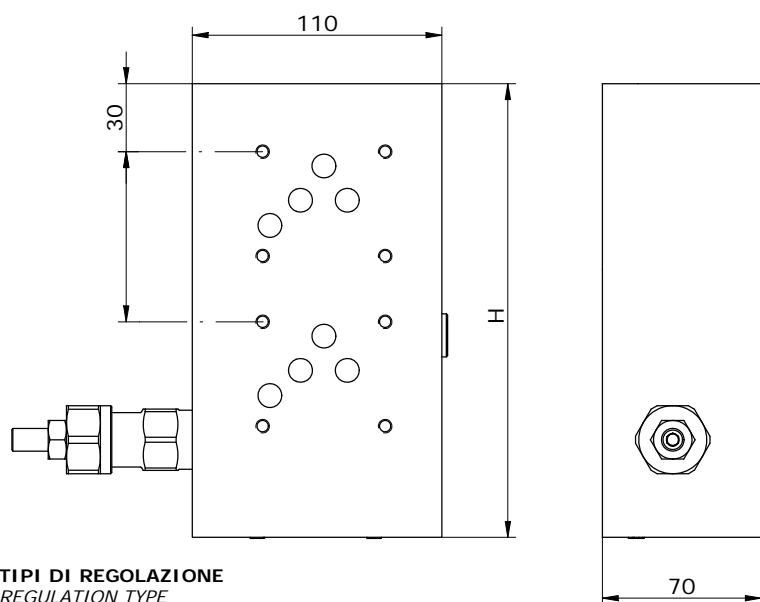
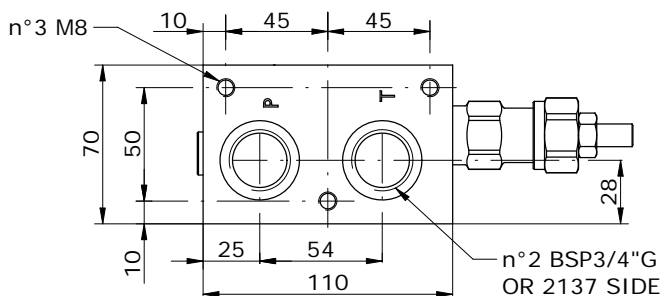
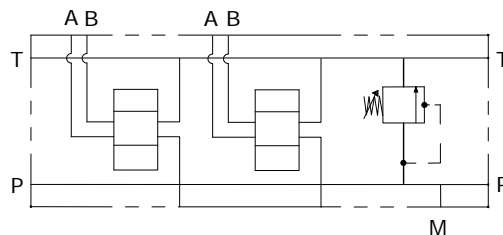

**TIPI DI REGOLAZIONE**  
**REGULATION TYPE**

	<b>H</b>	VITE CON CHIAVE ESAGONALE (standard) HEXAGONAL HEAD SCREW
	<b>K</b>	POMOLO KNOB
	<b>C</b>	FISSA CON CAPPUCCIO COVER CAP
	<b>I</b>	INVIOLABILE

POS.	02	03	04	05	06
H	200	275	350	425	500
K	180	255	330	405	480

**E\_10 - 05 -**

**S** = STEEL  
**A** = ALUMINUM

**12** = BSP 1/2G  
**34** = BSP 3/4G

MOUNTING POSITIONS: 02 ÷ 06

**0** = WITHOUT RELIEF VALVE  
**1** = WITH RELIEF VALVE  
**2** = RELIEF VALVE READY

**OMETTERE / OMIT**  
**H** = HEX. HEAD SCREW  
**K** = KNOB  
**C** = COVER CAP  
**I** = NOT ADJUSTABLE

**0** = WITHOUT RELIEF VALVE  
**1** = 5-55 BAR  
**2** = 25-110 BAR  
**3** = 75-250 BAR

\* see **CARTDRIGE VALVES** catalog

WWW.GPA.BY

**MONOBLOCCO A-B LATERALI 3/4", P 3/4"- T 1"**  
**MONOBLOCK A-B ON SIDE PORTS 3/4", P 3/4" - T 1"**

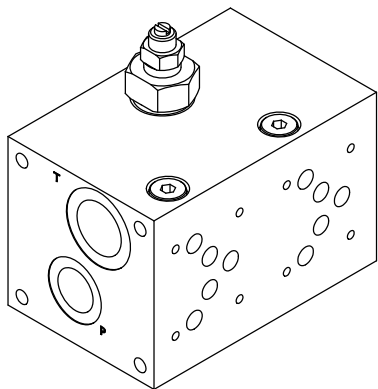

Schema idraulico  
Hydraulic diagram

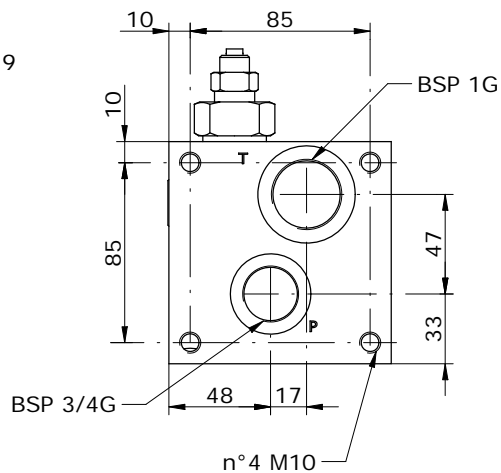
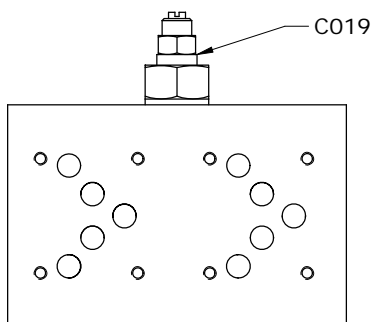
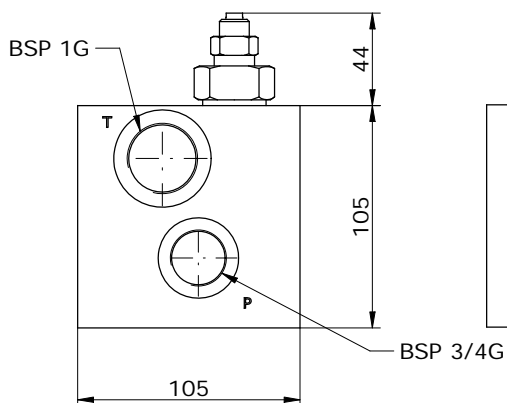
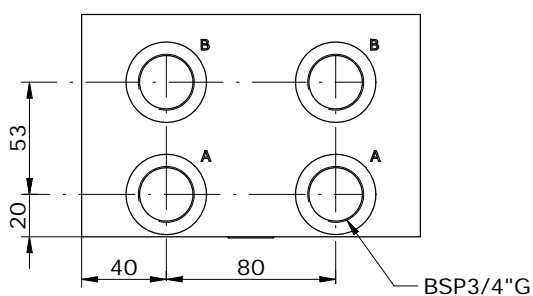
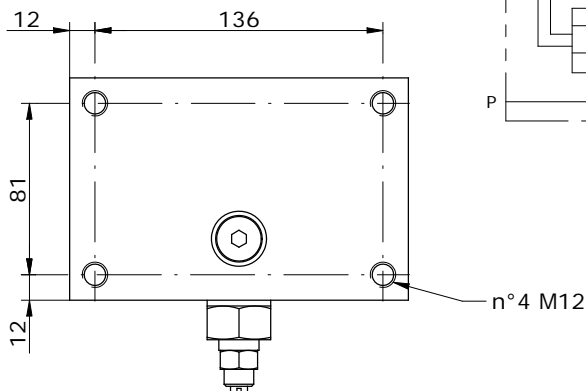
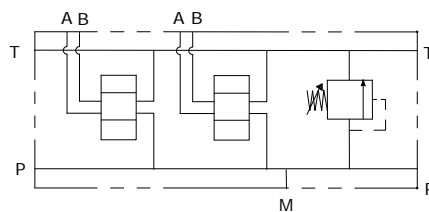

POS.	02	03	04	05	06	07	08
H	160	240	320	400	480	560	640
K	136	216	296	376	456	536	616

**E\_ - 10 - 11 - 34 - - - - -**

**A** = ALUMINUM  
**G** = CAST IRON

MOUNTING POSITIONS: 02÷08

**0** = WITHOUT RELIEF VALVE  
**1** = WITH R. V.  
**2** = R.V. READY

**H** = HEXAGONAL HEAD SCREW  
**K** = KNOB

**0** = WITHOUT R.V.  
**1** = 0-250 BAR  
**2** = 200-350 BAR

**MONOBLOCCO A-B LATERALI 1/2" BSP, P-T 3/4" BSP**  
**MONOBLOCK A-B ON SIDE 1/2" BSP, P-T 3/4" BSP**

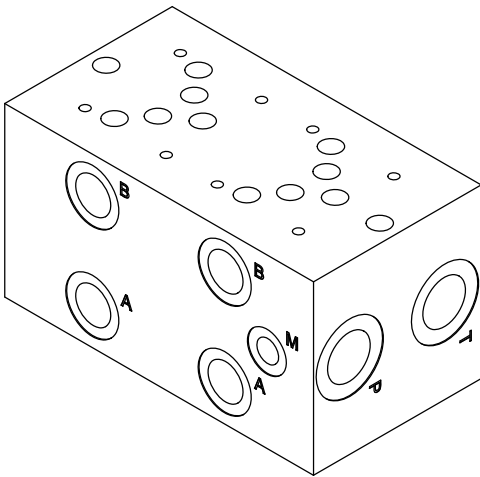

Schema idraulico  
Hydraulic diagram

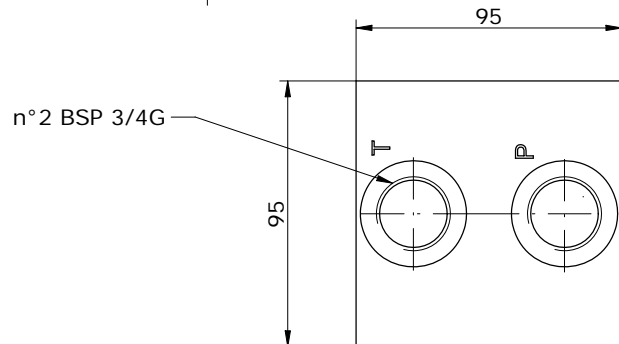
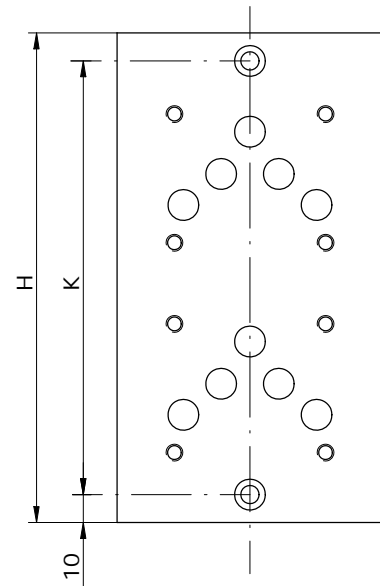
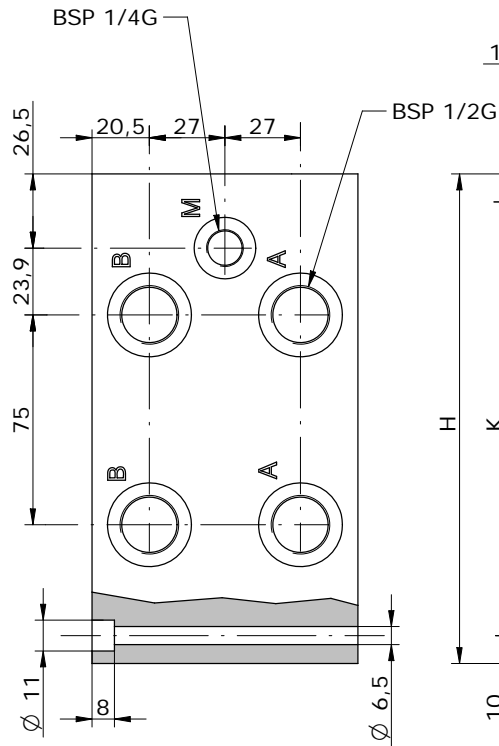
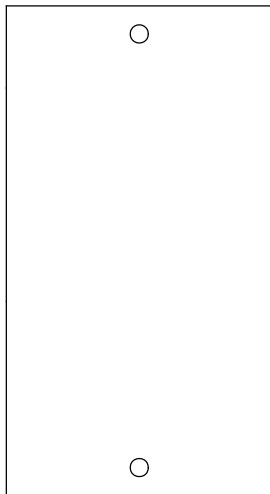
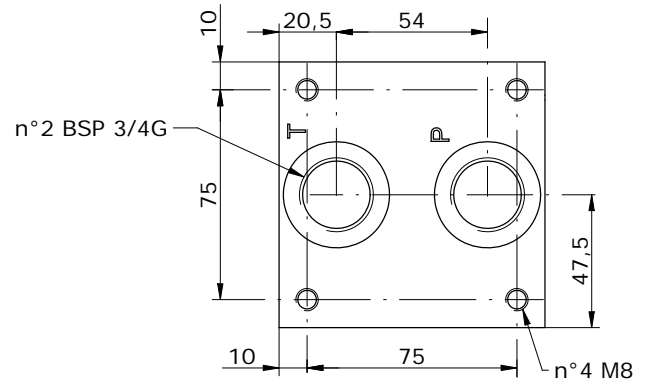
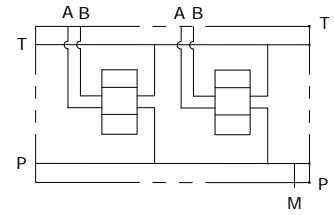

**E\_ 10 - 06 - 12 - \_\_\_ - 0**

POS.	01	02	03	04	05	06
H	100	175	250	325	400	475
K	84	159	234	309	384	459



**MONOBLOCCO A-B LATERALI 1/2" BSP, P-T 3/4" BSP  
MONOBLOCK A-B ON SIDE 1/2" BSP, P-T 3/4" BSP**

E\_ 10 - 06 - 12 - \_\_\_ - 1

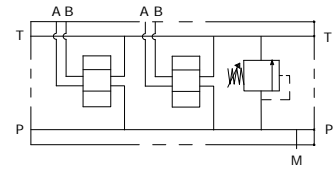
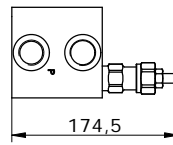
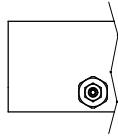
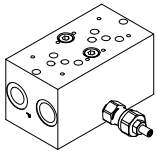

E\_ 10 - 06 - 12 - \_\_\_ - 2

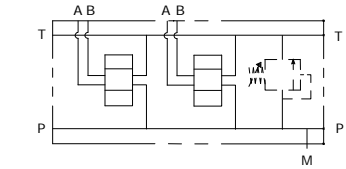
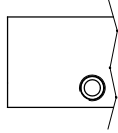
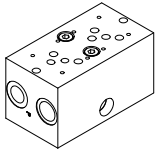

E\_ 10 - 06 - 12 - \_\_\_ - 3

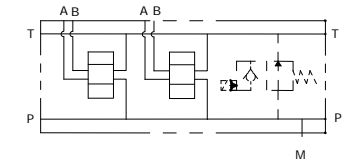
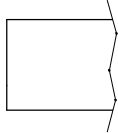
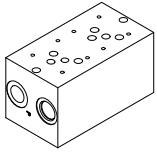

E\_ 10 - 06 - 12 - \_\_\_ - 4

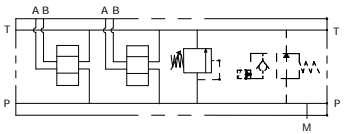
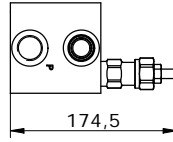
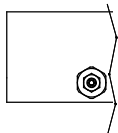
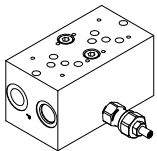

E\_ 10 - 06 - 12 - \_\_\_ - 5

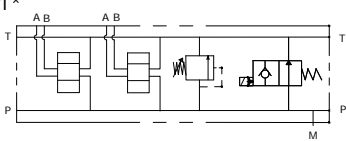
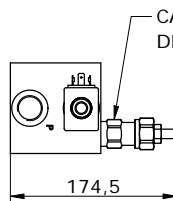
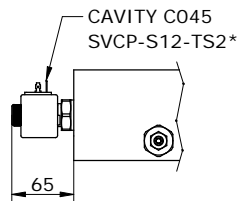
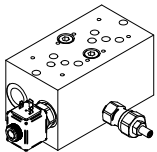

E\_ 10 - 06 - 12 - \_\_\_ - 6

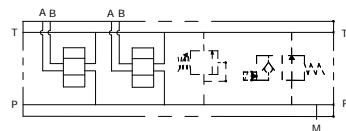
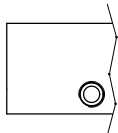
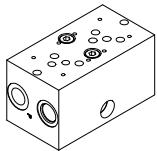

**E\_ 10 - 06 - 12 - \_\_\_\_\_**

S = STEEL  
A = ALUMINUM

MOUNTING POSITIONS: 01-06

0 = WITHOUT RELIEF VALVE  
1 = WITH RELIEF VALVE  
2 = RELIEF VALVE READY  
3 = VENTING VALVE READY  
4 = WITH R.V. AND V.V. READY  
5 = WITH R.V. AND V.V.  
6 = V.V. READY AND R.V. READY

0 = WITHOUT RELIEF VALVE  
1 = 5-55 BAR  
2 = 25-110 BAR  
3 = 75-250 BAR

0 = WITHOUT RELIEF VALVE  
H = HEX. HEAD SCREW    K = KNOB    C = COVER CAP    I = NOT ADJUSTABLE



SEALS  
N = BUNA  
V = VITON

VENTING VALVE  
000 = WITHOUT V.V.  
TS2 = NORMALLY OPEN

VENTING VALVE  
0 = NO MANUAL OVERRIDE  
2 = PUSH AND TWIST  
4 = PUSH BOTTOM

CONNECTOR TYPE  
O = WITHOUT COIL  
C = CAVI / LEADS  
D = DIN 43650  
G = DEUTSCH DT04-2P  
A = AMP JUNIOR

TENSIONE / VOLTAGE  
000 = WITHOUT COIL  
D12 = 12 VDC  
D24 = 24 VDC  
D26 = 26 VDC

\*see *CARTDRIGE VALVES* catalog

WWW.GPA.BY

**MONOBLOCCO A-B LATERALI P-T 3/4" BSP**  
**MONOBLOCK A-B ON SIDE P-T 3/4" BSP**

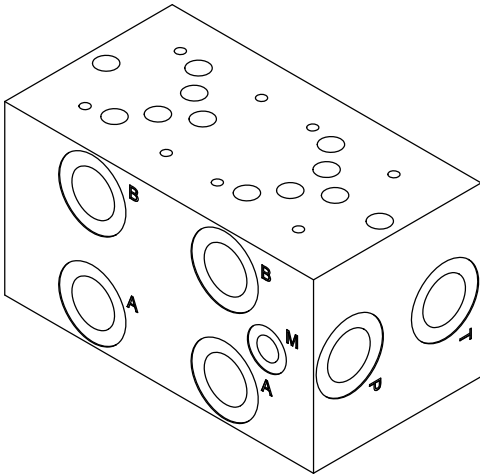
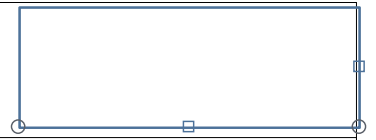

Schema idraulico  
Hydraulic diagram

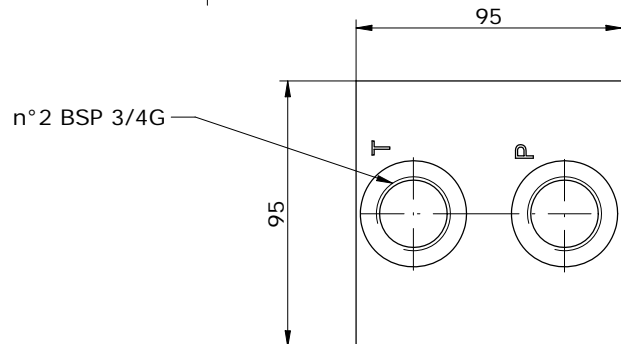
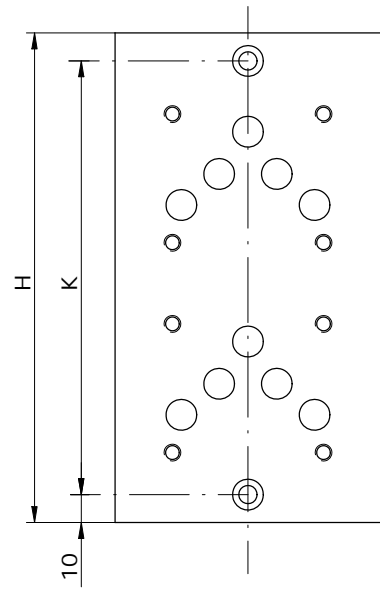
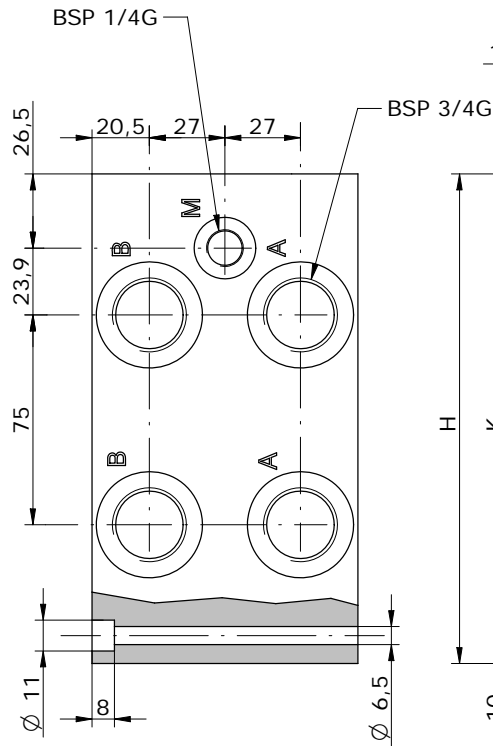
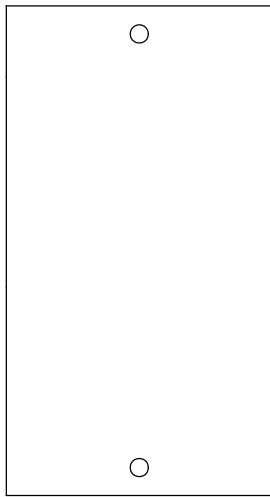
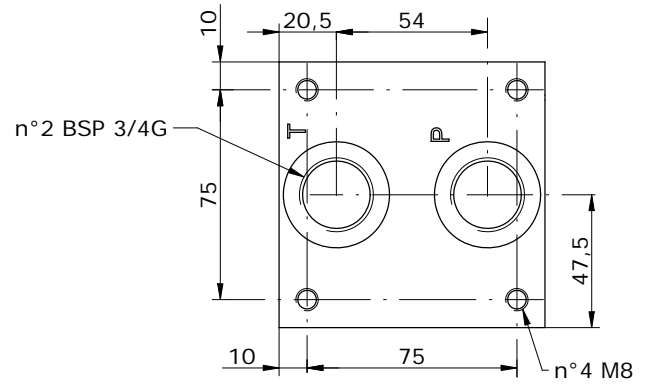
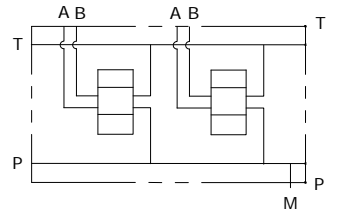

**E\_ 10 - 06 - 34 - \_\_\_ - 0**

POS.	01	02	03	04	05	06
H	100	175	250	325	400	475
K	84	159	234	309	384	459

**MONOBLOCCO A-B LATERALI P-T 3/4" BSP**  
**MONOBLOCK A-B ON SIDE P-T 3/4" BSP**



**E\_ 10 - 06 - 34 - \_\_\_ - 1**

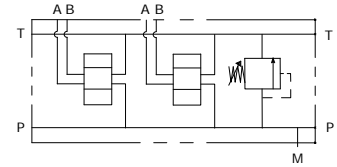
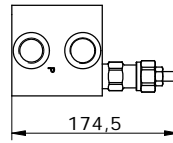
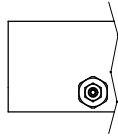
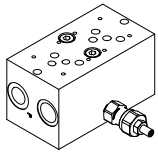

**E\_ 10 - 06 - 34 - \_\_\_ - 2**

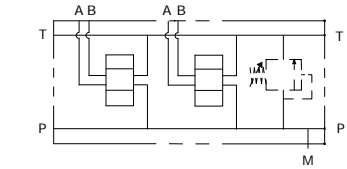
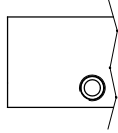
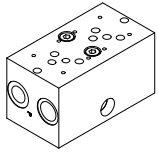

**E\_ 10 - 06 - 34 - \_\_\_ - 3**

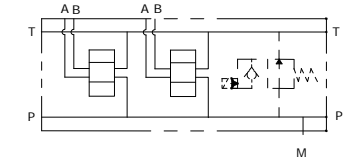
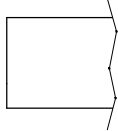
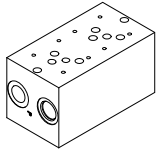

**E\_ 10 - 06 - 34 - \_\_\_ - 4**

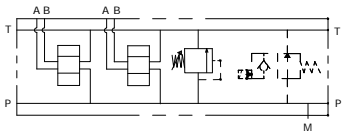
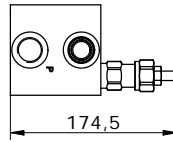
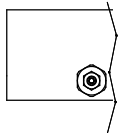
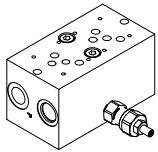

**E\_ 10 - 06 - 34 - \_\_\_ - 5**

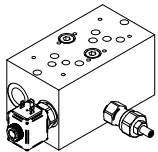

CAVITY C045  
SVCPC-S12-TS2\*

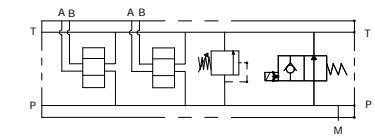
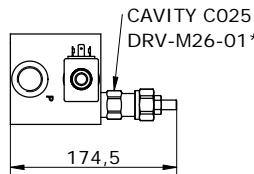
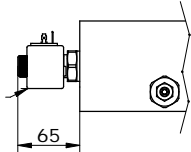

**E\_ 10 - 06 - 34 - \_\_\_ - 6**

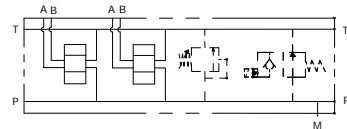
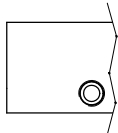
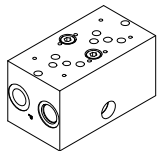

**E\_ 10 - 06 - 34 - \_\_\_\_\_**

**S** = STEEL  
**A** = ALUMINUM

MOUNTING POSITIONS: 01-06

**0** = WITHOUT RELIEF VALVE  
**1** = WITH RELIEF VALVE  
**2** = RELIEF VALVE READY  
**3** = VENTING VALVE READY  
**4** = WITH R.V. AND V.V. READY  
**5** = WITH R.V. AND V.V.  
**6** = V.V. READY AND R.V. READY

**0** = WITHOUT RELIEF VALVE  
**1** = 5-55 BAR  
**2** = 25-110 BAR  
**3** = 75-250 BAR

**0** = WITHOUT RELIEF VALVE  
**H** = HEX. HEAD SCREW    **K** = KNOB    **C** = COVER CAP    **I** = NOT ADJUSTABLE



**SEALS**  
**N** = BUNA  
**V** = VITON

**VENTING VALVE**  
**000** = WITHOUT V.V.  
**TS2** = NORMALLY OPEN

**VENTING VALVE**  
**0** = NO MANUAL OVERRIDE  
**2** = PUSH AND TWIST  
**4** = PUSH BOTTOM

**CONNECTOR TYPE**  
**0** = WITHOUT COIL  
**C** = CAVI / LEADS  
**D** = DIN 43650  
**G** = DEUTSCH DT04-2P  
**A** = AMP JUNIOR

**TENSIONE / VOLTAGE**  
**000** = WITHOUT COIL  
**D12** = 12 VDC  
**D24** = 24 VDC  
**D26** = 26 VDC

\*see **CARTDRIGE VALVES** catalog

WWW.GPA.BY

**BASE DI CHIUSURA CETOP 7  
END PLATE CETOP 7**

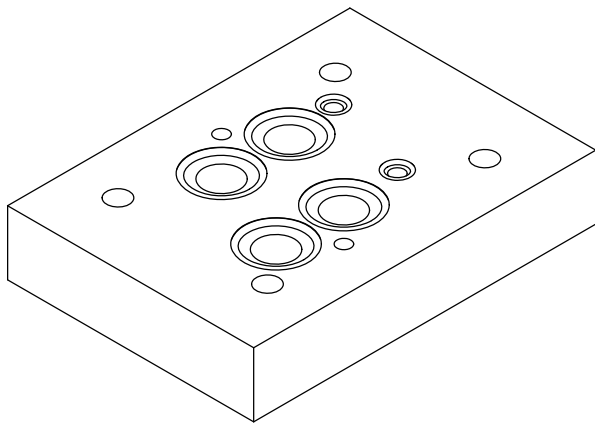

Schema idraulico  
Hydraulic diagram

**0**



**1**

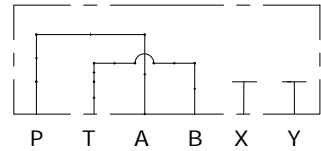

**2**

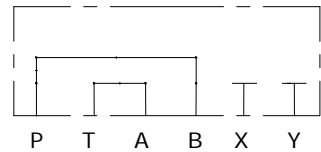

VERSION	R	
E_16-03-30-0	30	STANDARD
E_16-03-30-1	45	ON REQUEST
E_16-03-30-2	30	ON REQUEST

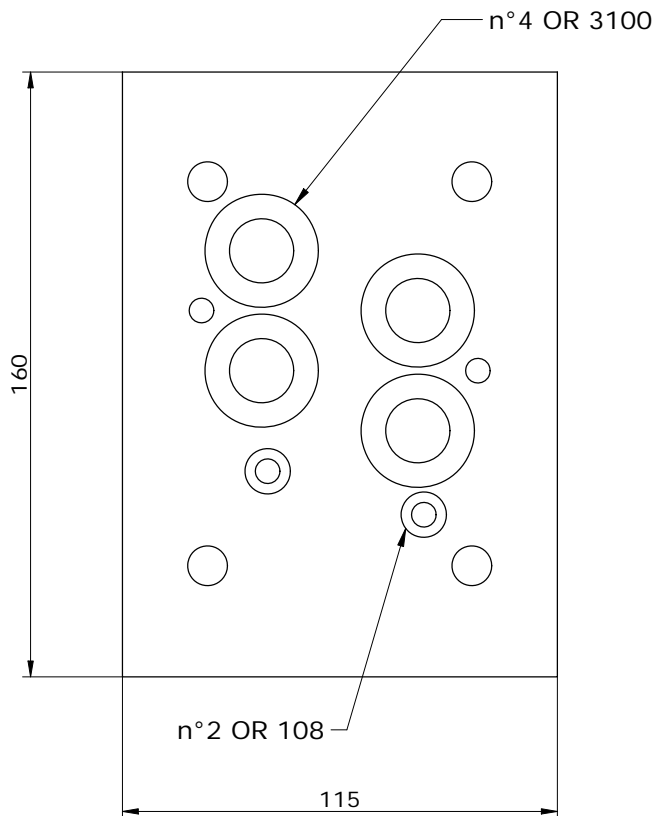
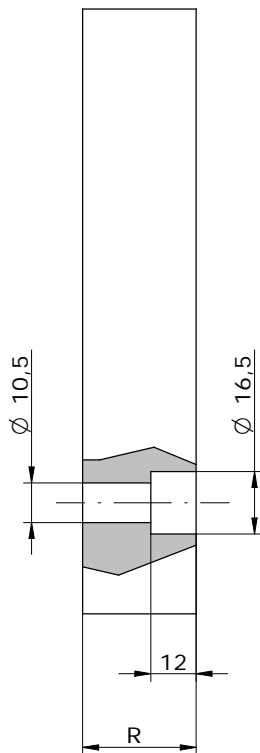

**E\_ 16 - 03 - 30 - \_**

**S** = STEEL  
**A** = ALUMINUM

SEE DIAGRAMS

**BASE SINGOLA CETOP 7 CON UTILIZZI A-B-P-T POSTERIORI**  
**SUB-PLATE CETOP 7 WITH A-B-P-T PORTS BACK**

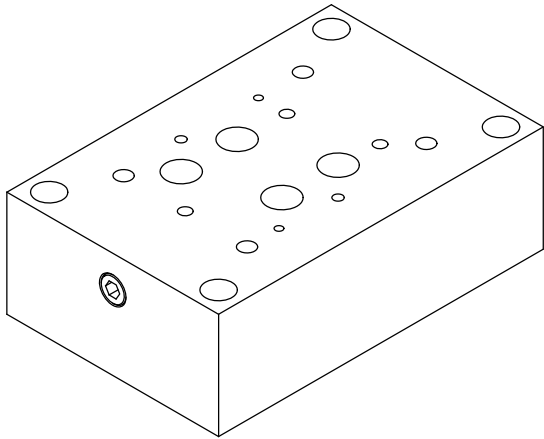

Schema idraulico  
Hydraulic diagram

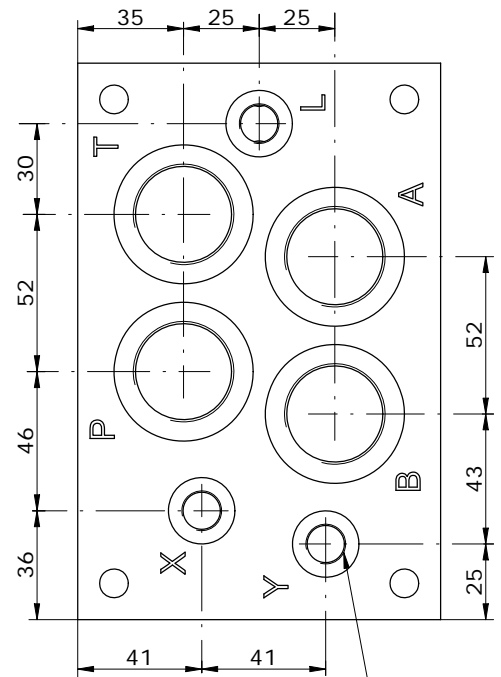
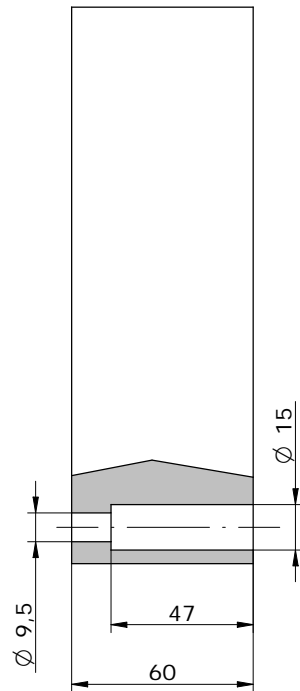
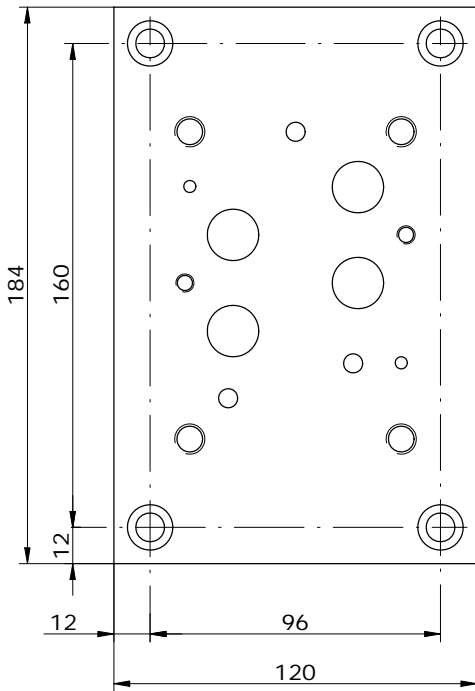
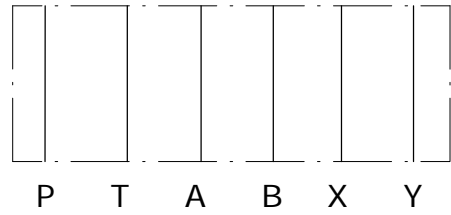

**E\_ 16 - 01 -**

**S** = STEEL  
**A** = ALUMINUM

**34** = BSP 3/4G - ON REQUEST  
**100** = BSP 1G - STANDARD

**BASE RIDUZIONE NG16-NG10**  
**REDUCTION PLATE NG16-NG10**

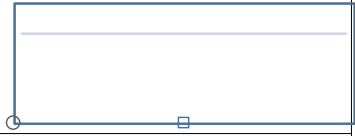

Schema Idrraulico  
 Hydraulic diagram

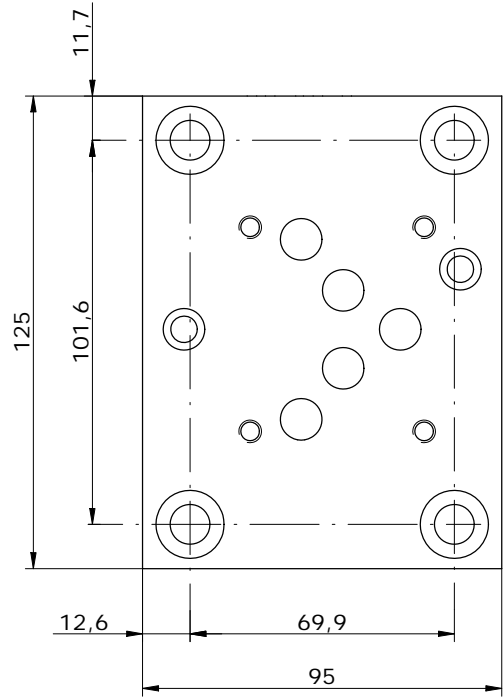
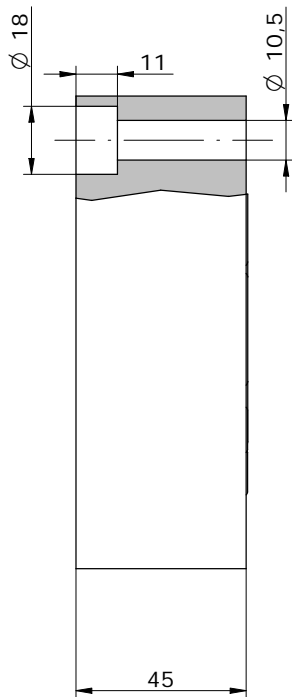
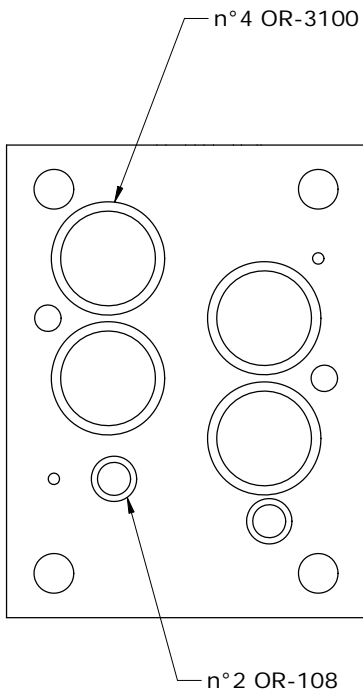
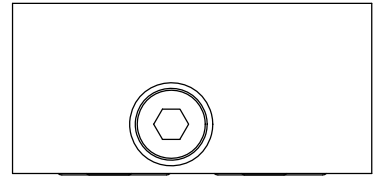
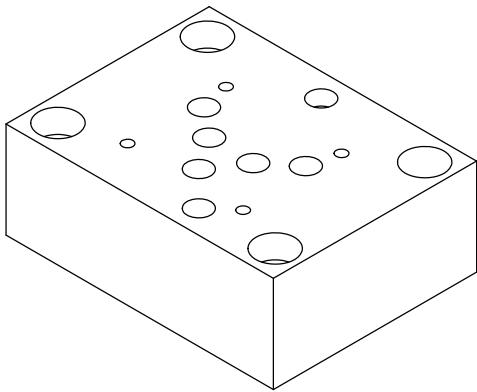
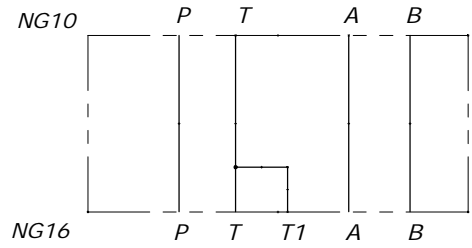

**E\_ 16 - 08 - 00**

**S** = STEEL  
**A** = ALLUMINUM

**BASE SINGOLA CETOP 7 CON UTILIZZI A-B-P-T LATERALI**  
**SUB-PLATE CETOP 7 WITH A-B-P-T ON SIDE PORTS**

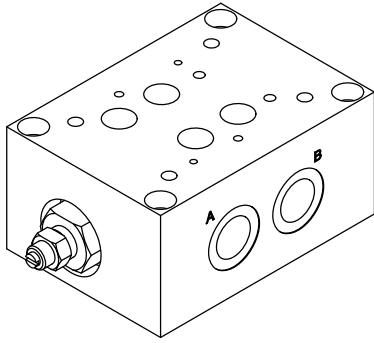

Schema idraulico  
Hydraulic diagram

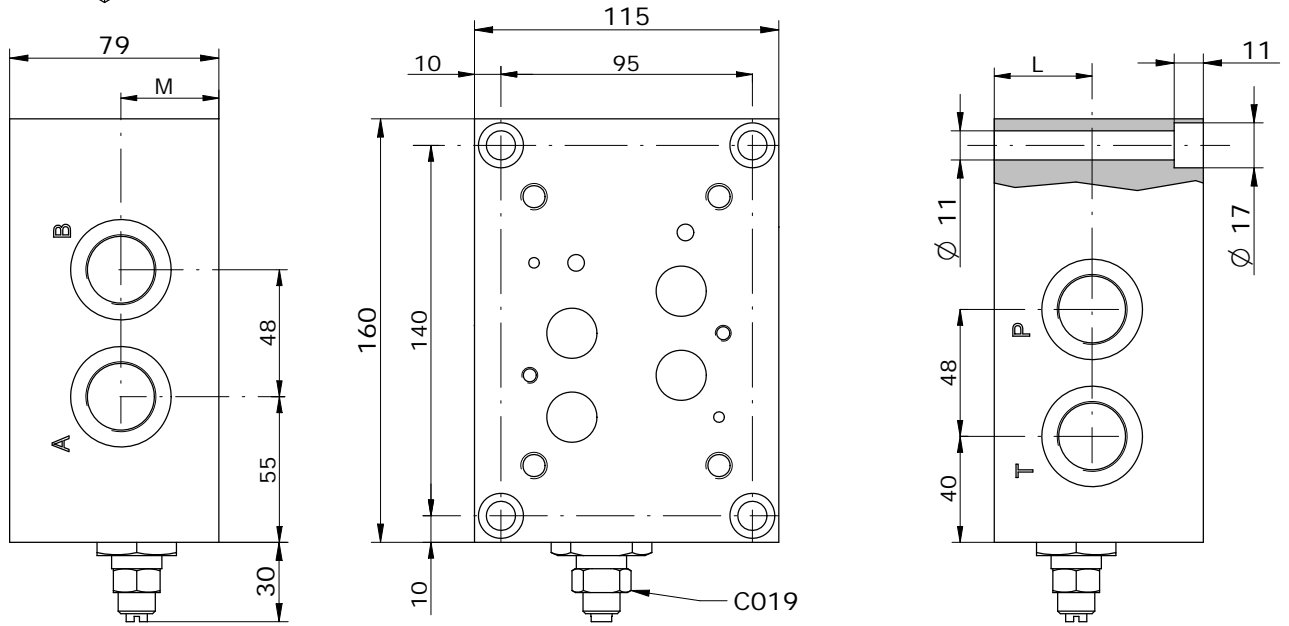
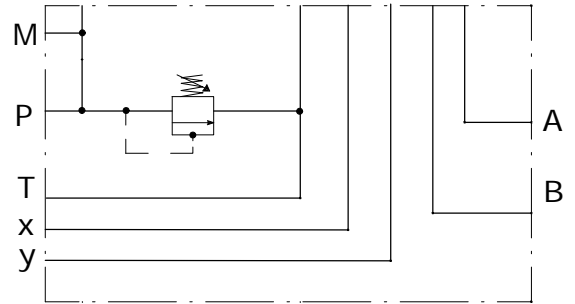

VERSION	L	M
E_16-02-34	37	37
E_16-02-100	37	40
E_16-02-114	33	33

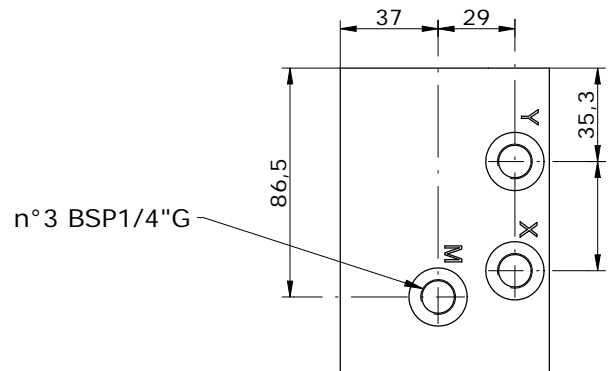

**E\_ 16 - 02 - \_\_\_\_\_ - \_\_\_\_\_ - \_\_\_\_\_**

**S** = STEEL  
**A** = ALUMINUM

**34** = BSP 3/4G  
**100** = BSP 1G  
**114** = BSP 1.1/4G

**0** = WITHOUT RELIEF VALVE  
**1** = WITH RELIEF VALVE  
**2** = RELIEF VALVE READY

**0** = WITHOUT RELIEF VALVE  
**1** = 0-250 BAR  
**2** = 200-350 BAR

**BASE SINGOLA CETOP 7 CON UTILIZZI A-B-x-y LATERALI, P - T POSTERIORI**  
**SUB-PLATE CETOP 7 WITH A-B-x-y ON SIDE PORTS AND P - T PORTS BACK**

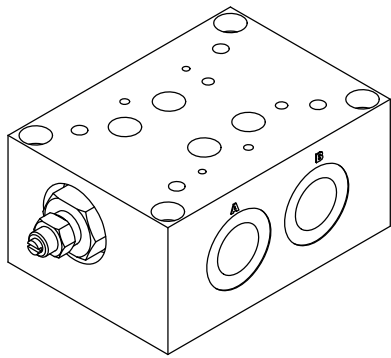

Schema idraulico  
Hydraulic diagram

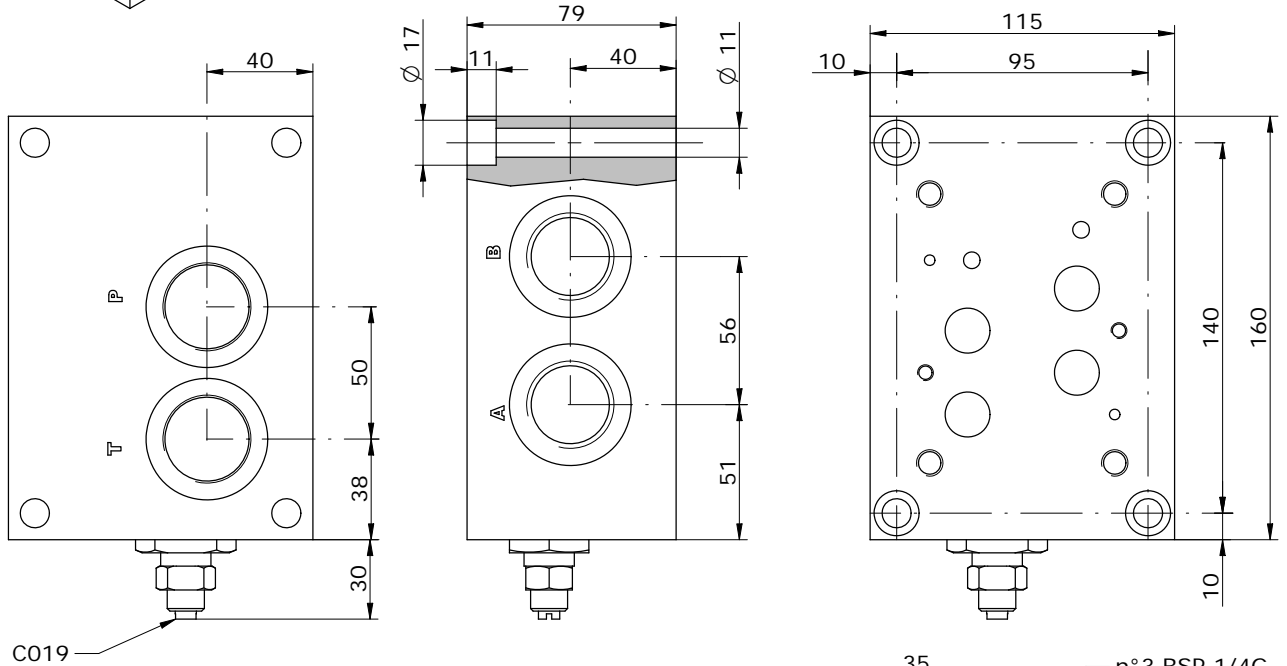
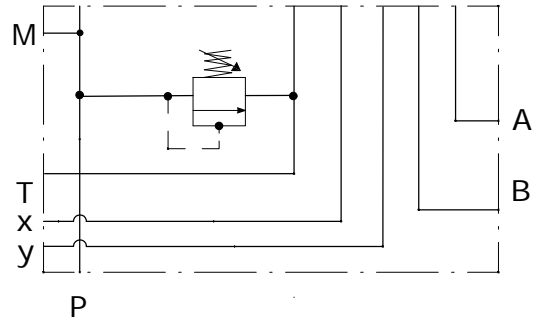

**E\_ 16 - 05 - \_\_\_\_\_ - \_\_\_\_\_ - \_\_\_\_\_**

**S** = STEEL  
**A** = ALUMINUM

**100** = BSP 1G  
**114** = BSP 1.1/4G

**0** = WITHOUT RELIEF VALVE  
**1** = WITH RELIEF VALVE  
**2** = RELIEF VALVE READY

**0** = WITHOUT RELIEF VALVE  
**1** = 0-50 BAR  
**2** = 200-350 BAR



**MONOBLOCCO CETOP 7 A-B POSTERIORI, P-T LATERALI**  
**MONOBLOCK CETOP 7 A-B BACK PORTS, P-T ON SIDE**

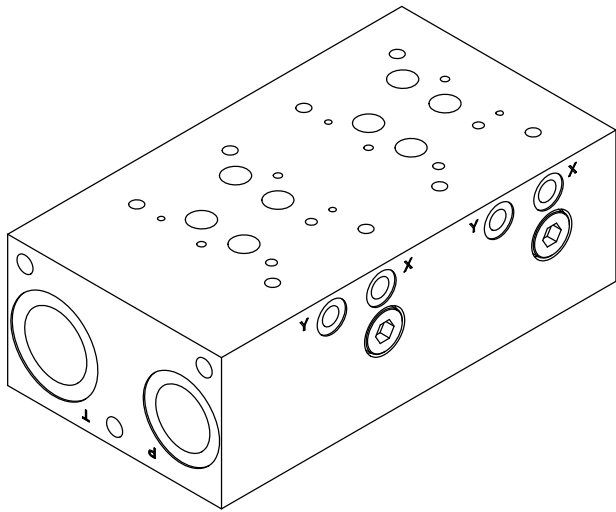

Schema idraulico  
Hydraulic diagram

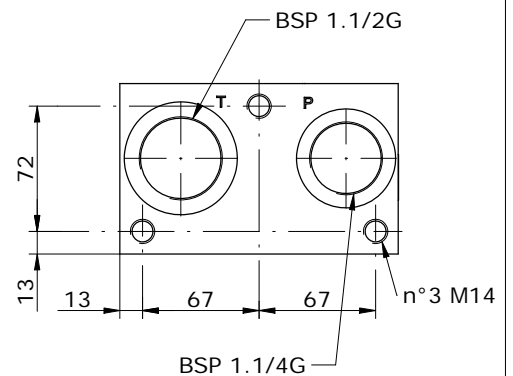
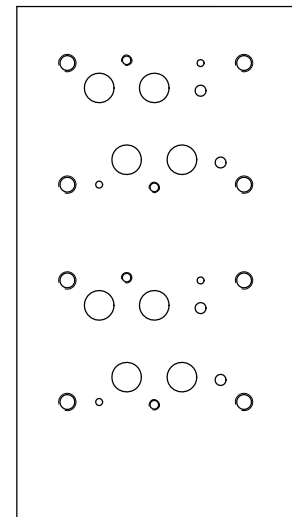
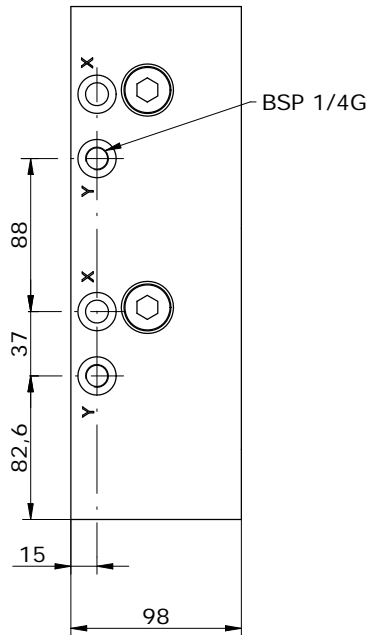
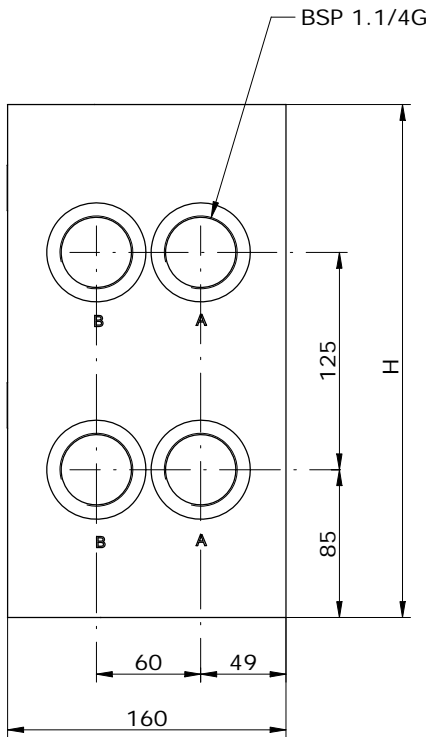
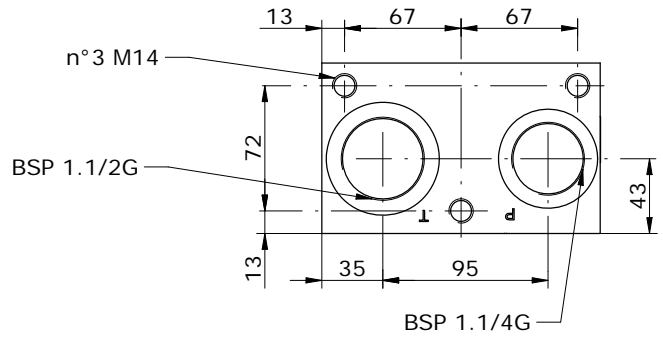
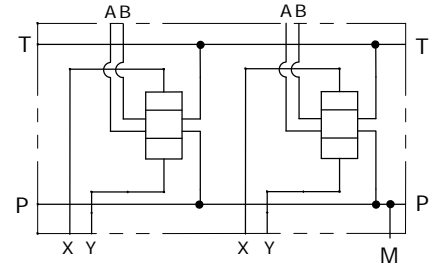

POS.	01	02	03	04
H	//	295	420	545

**E\_ 16 - 04 - 114 -**

**S = STEEL**  
**A = ALUMINUM**

MOUNTING POSITIONS: 02 ÷ 4

**MONOBLOCCO CETOP 7 A-B LATERALI 1", P 1.1/4", T 1.1/2"**  
**MONOBLOCK CETOP 7 A-B ON SIDE 1", P 1.1/4", T 1.1/2"**

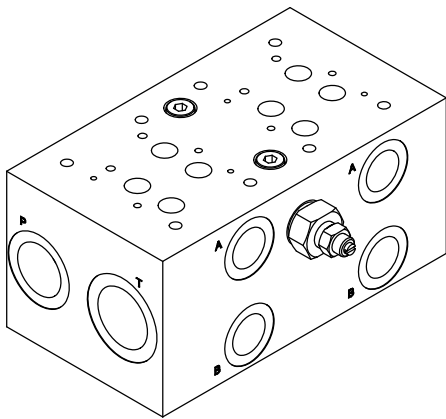
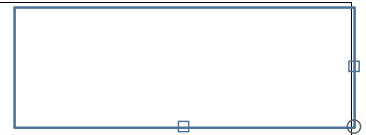

Schema idraulico  
Hydraulic diagram

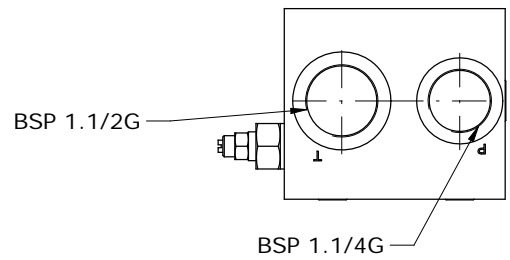
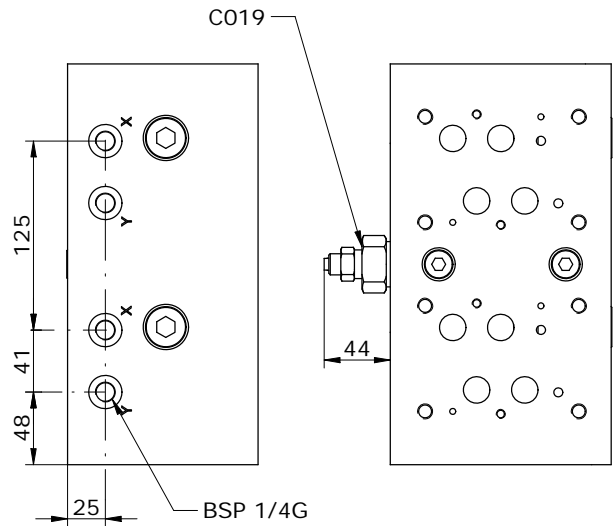
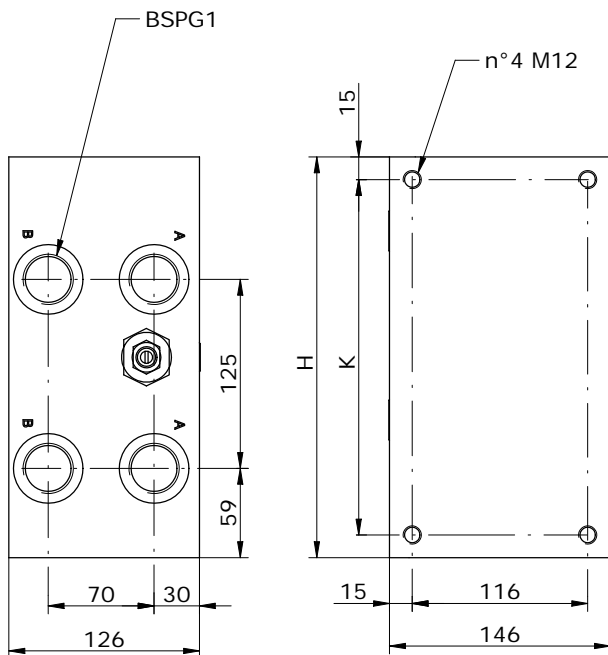
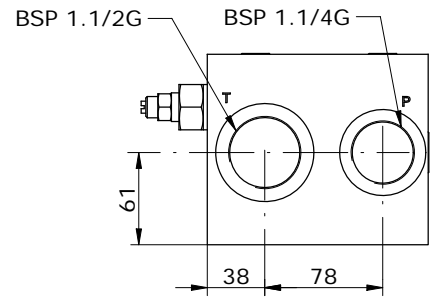
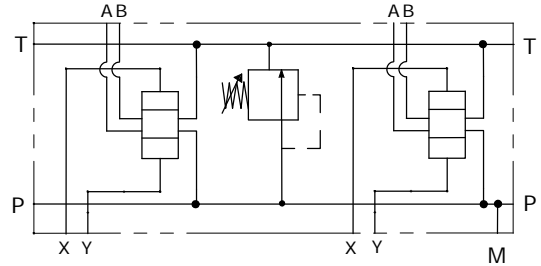

POS.	02	03	04
H	265	390	515
K	235	360	485

**E\_ 16 - 06 - 100 - \_ \_ \_ \_**

**S** = STEEL  
**A** = ALUMINUM

MOUNTING POSITIONS: 02 ÷ 04

**0** = WITHOUT RELIEF VALVE  
**1** = 0-50 BAR  
**2** = 200-350 BAR

**0** = WITHOUT RELIEF VALVE  
**1** = WITH RELIEF VALVE  
**2** = RELIEF VALVE READY

***Note - Notes***

Dotted lines for writing notes.

**BASE DI CHIUSURA - COLLEGAMENTO CETOP 8**  
**END - SUB - PLATE CETOP 8**

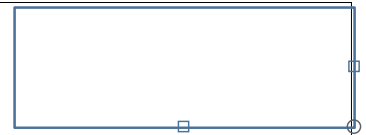

Schema idraulico  
Hydraulic diagram

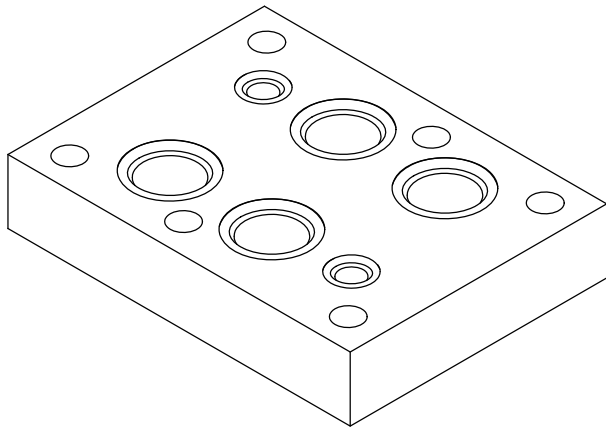

**0**

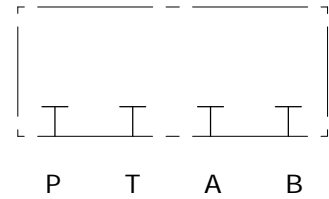

**1**

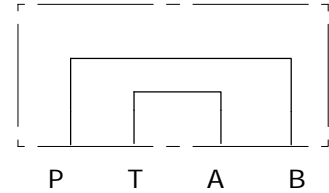

**2**

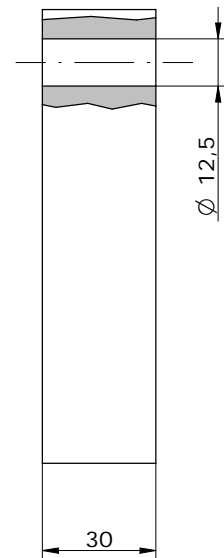
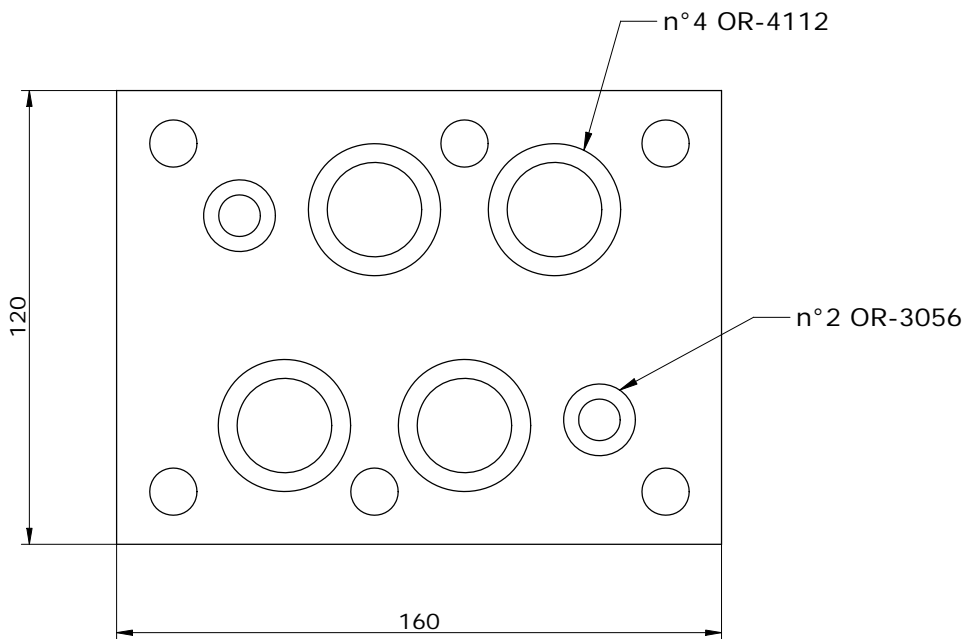
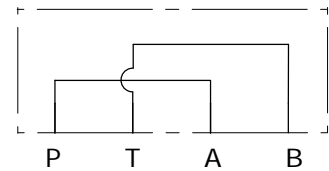

**E\_ 25 - 00 - 30 - \_**

**S** = STEEL  
**A** = ALUMINUM

SEE DIAGRAMS

**BASE SINGOLA CETOP 8 CON UTILIZZI A-B-P-T LATERALI P-T POSTERIORI**  
**SUB-PLATE CETOP 8 WITH A-B-P-T PORTS ON SIDE P-T BACK**

Schema idraulico  
Hydraulic diagram

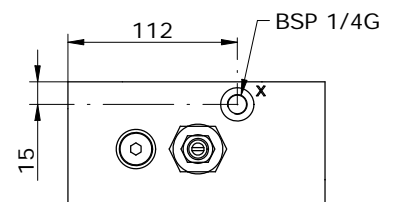
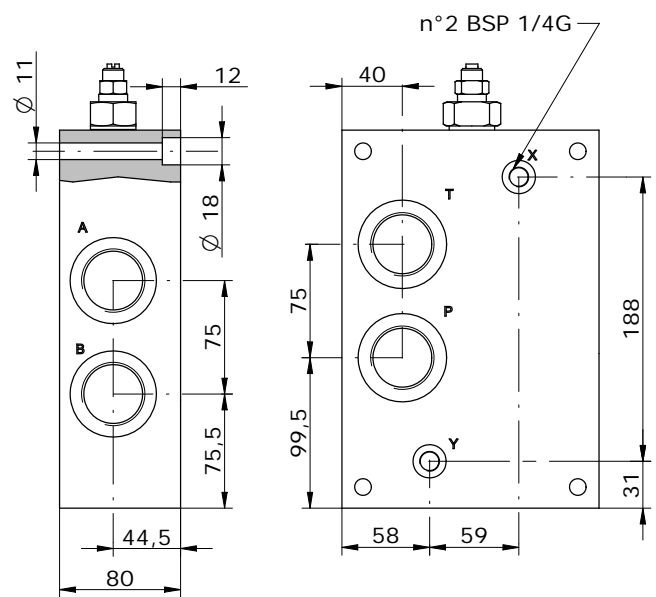
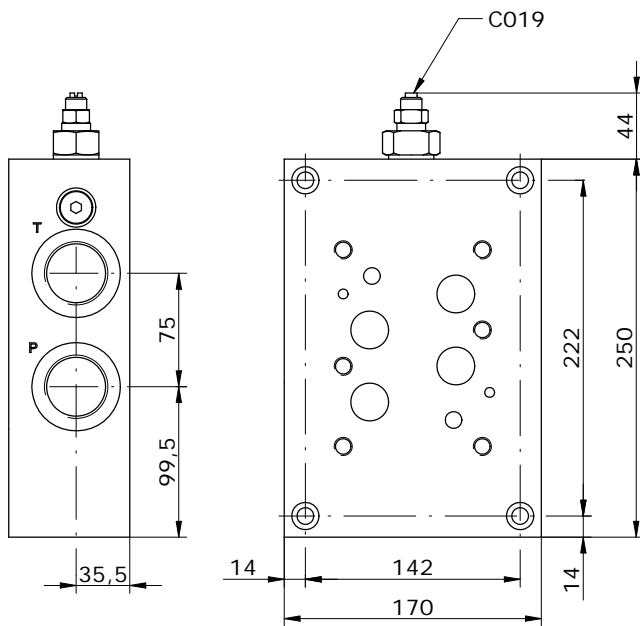
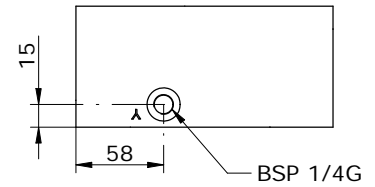
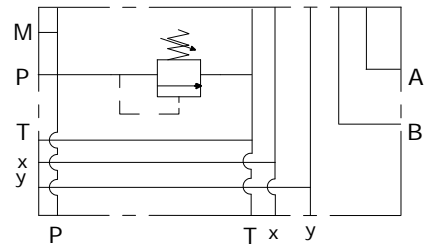
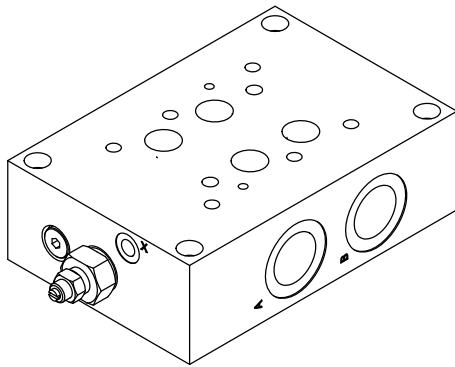

**E\_ 25 - 01 - - - -**

**S** = STEEL  
**A** = ALUMINUM

**114** = 1.1/4G  
**112** = 1.1/2G

**0** = WITHOUT RELIEF VALVE  
**1** = WITH RELIEF VALVE  
**2** = RELIEF VALVE READY

**0** = WITHOUT RELIEF VALVE  
**1** = 0-250 BAR  
**2** = 200-350 BAR

**BASE CETOP 8 A-B-P LATERALI 1.1/4", T 1.1/2"**  
**SUB-PLATE CETOP 8 A-B-P PORTS ON SIDE 1.1/4", T 1.1/2"**

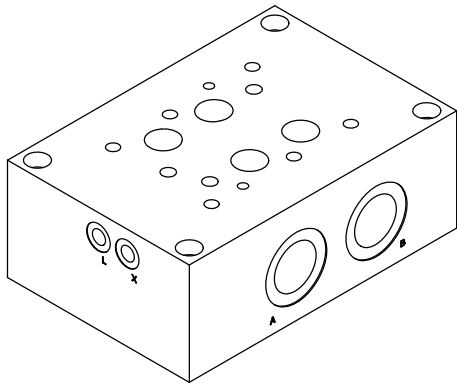

Schema idraulico  
Hydraulic diagram

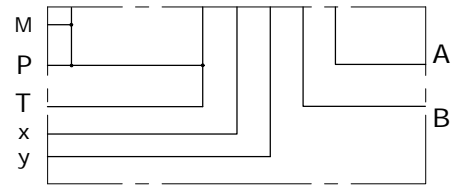

n°2 BSP 1/4G

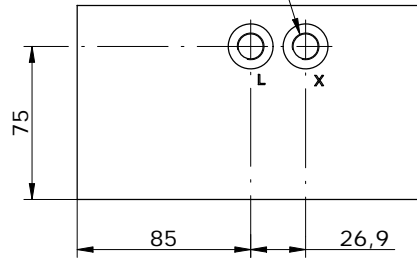

n°2 BSP 1.1/4G

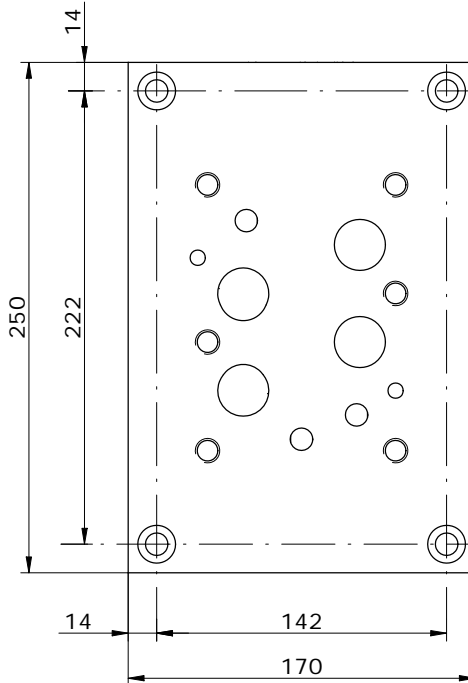
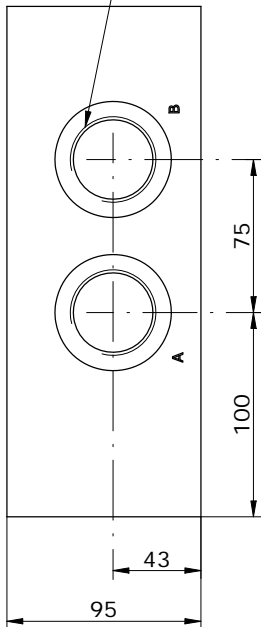

BSP 1.1/4G

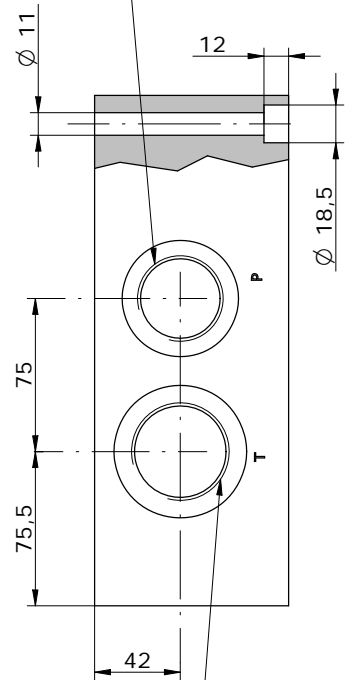

BSP1.1/2G

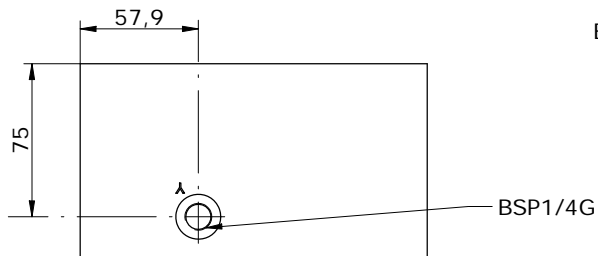

**E\_ 25 - 05 - 114**

**S = STEEL**  
**A = ALUMINIUM**

BASE CETOP 8 A-B-P LATERALI SAE6000 1.1/4",  
 T LATERALE SAE3000 1.1/2"  
 SUB-PLATE CETOP 8 A-B-P PORTS ON SIDE SAE6000 1.1/4",  
 T ON SIDE SAE3000 1.1/2"

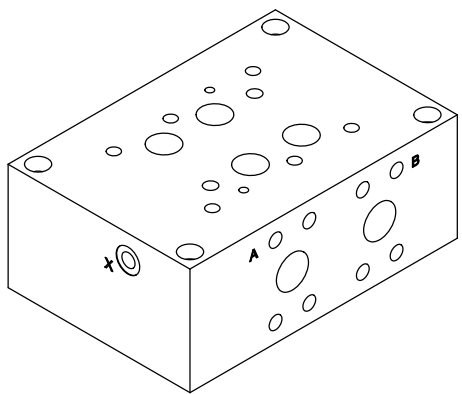

Schema idraulico  
 Hydraulic diagram

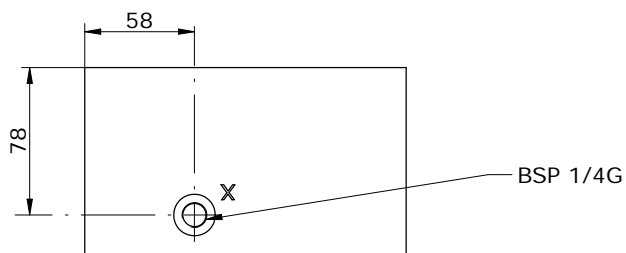
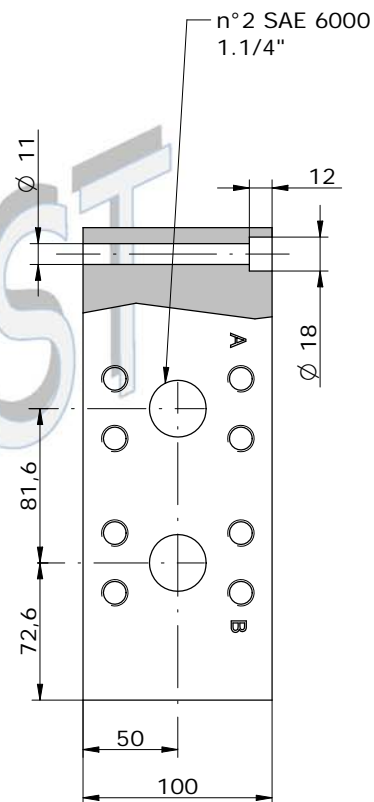
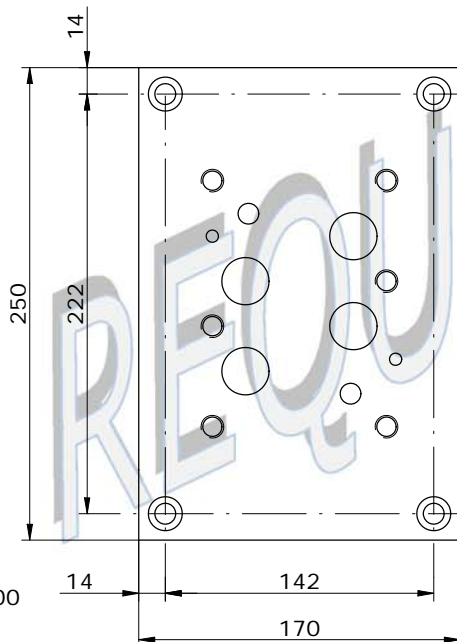
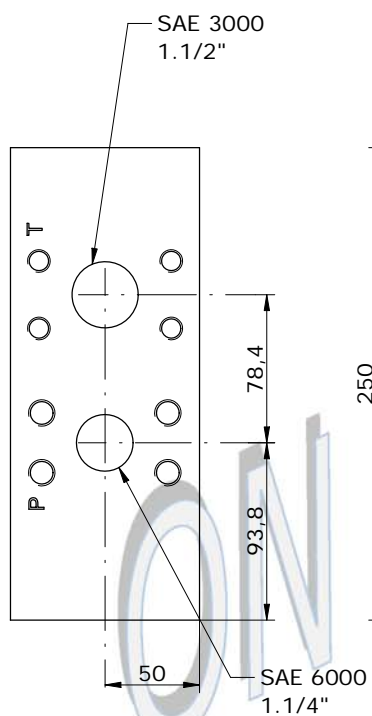
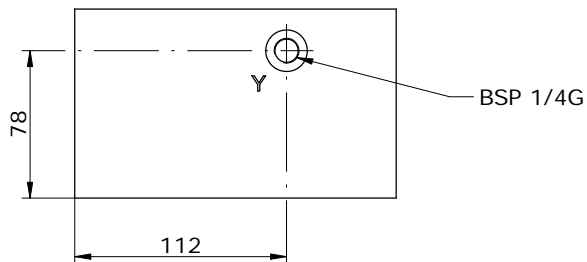
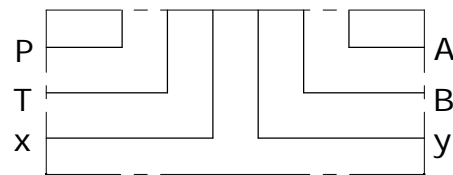

**E\_ 25 - 03 - 114**

**S = STEEL**  
**A = ALUMINUM**

**MONOBLOCCO CETOP 8 A-B POSTERIORI 1.1/4", P-T-X-Y LATERALI**  
**MONOBLOCK CETOP 8 A-B BACK 1.1/4", P-T-X-Y ON SIDE**

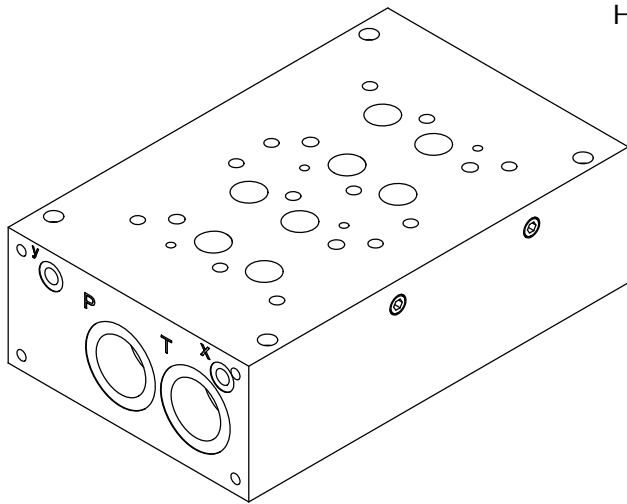

Schema idraulico  
Hydraulic diagram

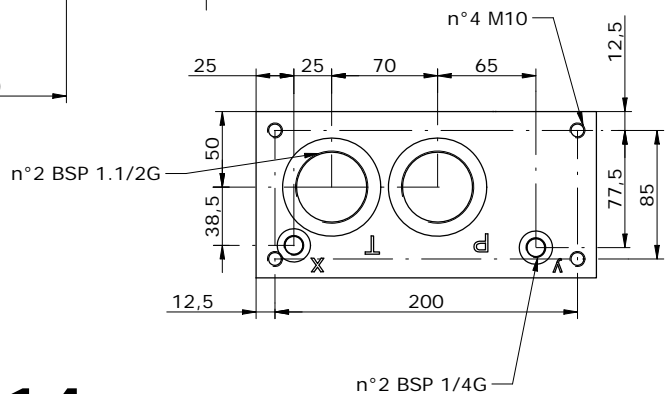
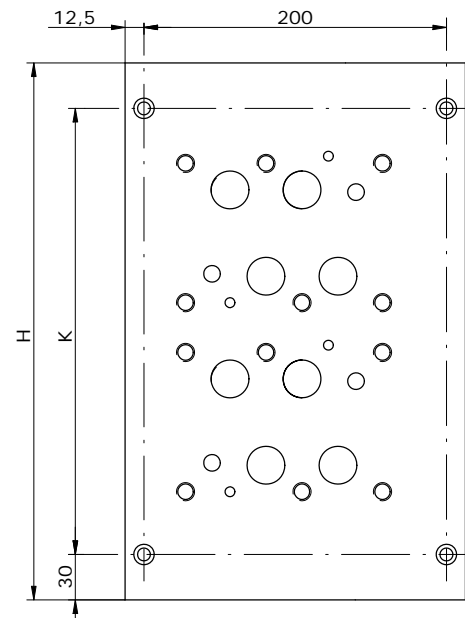
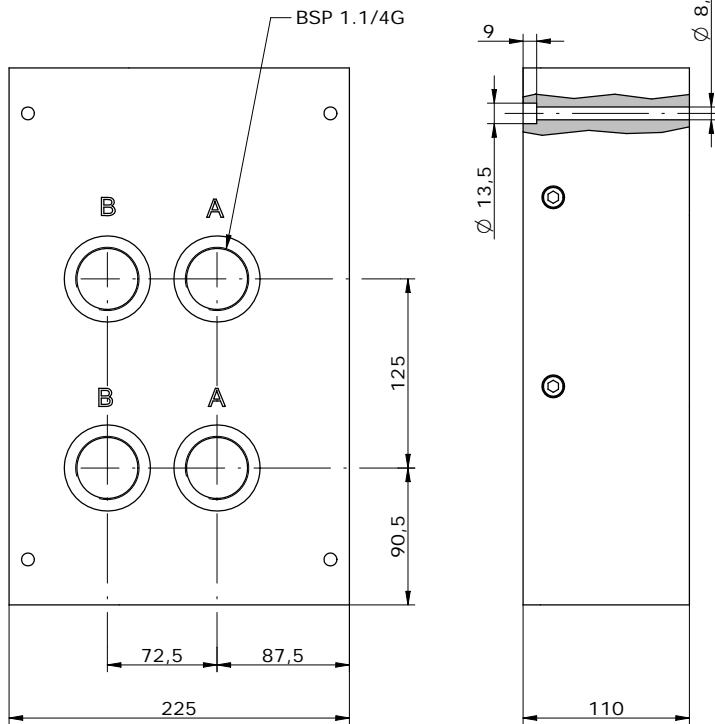
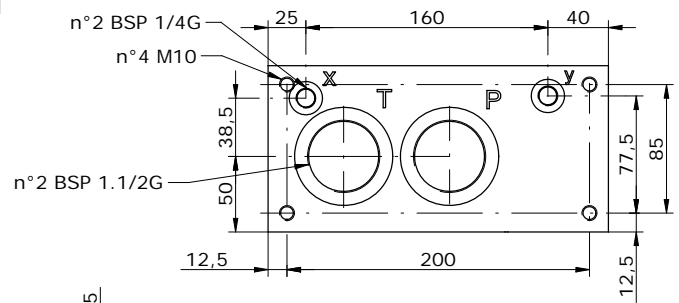
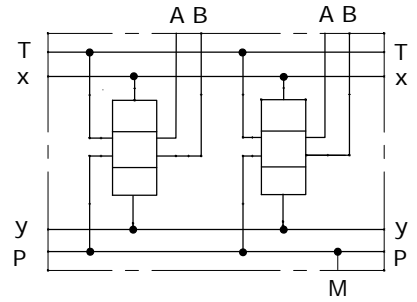

POS.	02	03	04	05
H	355	480	605	730
K	295	420	545	670

**E\_ 25 - 02 - 114 -**

**S = STEEL**  
**A = ALUMINUM**

MOUNTING POSITIONS: 02 ÷ 05







**BASE MODULARE CETOP 3 CON VALVOLA REGOLATRICE DI PRESSIONE**  
**STARTING PLATE FOR MODULAR ELEMENTS NG6 WITH RELIEF VALVE**

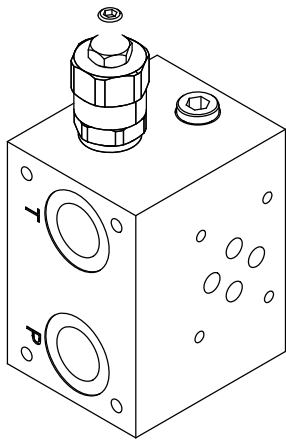

Schema idraulico  
Hydraulic diagram

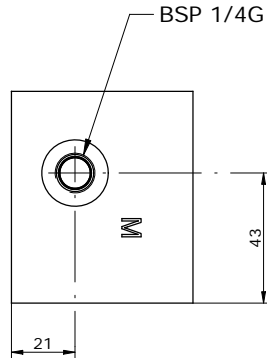
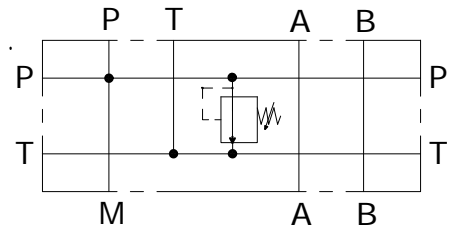

TIPI DI REGOLAZIONE PER V. MAX  
REGULATION TYPE FOR RELIEF VALVE

	H	VITE CON CHIAVE ESAGONALE (standard) HEXAGONAL HEAD SCREW
	K	POMOLO KNOB
	C	FISSA CON CAPPUCCIO COVER CAP
	I	INVIOLABILE

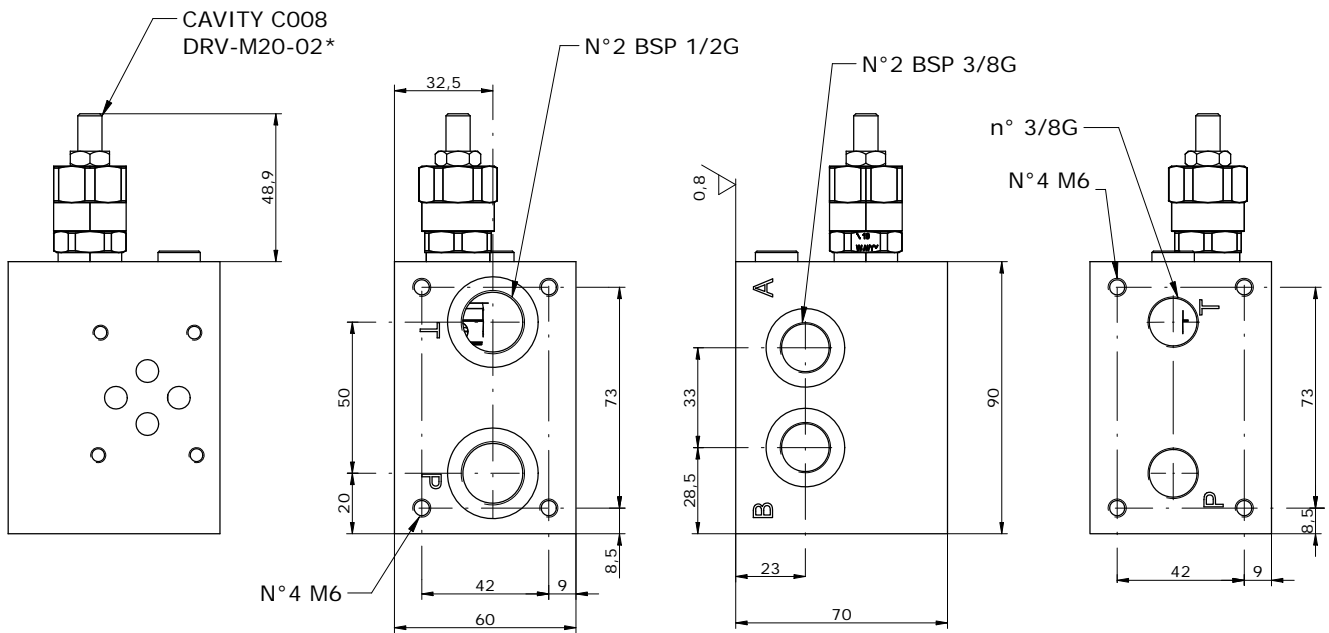

**E\_ 610 - 08 - 38 - - - -**

**S = STEEL**  
**A = ALUMINUM**

**1 = WITH RELIEF VALVE**  
**2 = RELIEF VALVE READY**

**OMETTERE / OMIT**  
**H = HEXAGONAL HEAD SCREW**  
**K = KNOB**  
**C = COVER CAP**  
**I = NOT ADJUSTABLE**

**0 = WITHOUT RELIEF VALVE**  
**1 = 5-50 BAR**  
**2 = 20-110 BAR**  
**3 = 50-220 BAR**  
**4 = 100-350 BAR**  
**5 = 100-420 BAR**

\*see *CARTDRIGE VALVES* catalog

WWW.GPA.BY

**BASE MODULARE CETOP 3 CON COLLEGAMENTO PARALLELO A-B 3/8" BSP**  
**MODULAR PLATE CETOP 3 WITH A-B PORTS BACK 3/8" BSP**

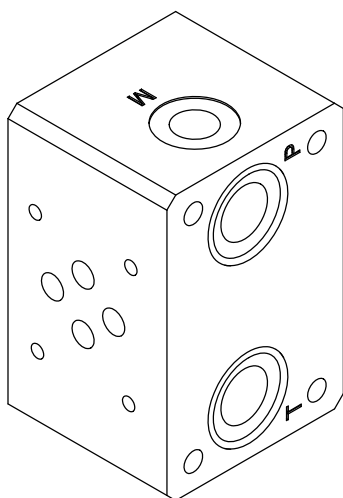

Schema idraulico  
Hydraulic diagram

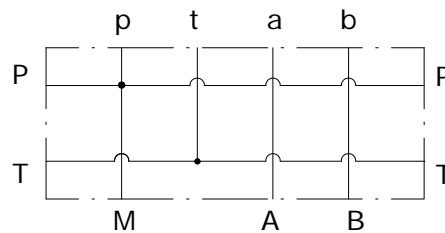

n°2 BSP 3/8G  
OR-2093

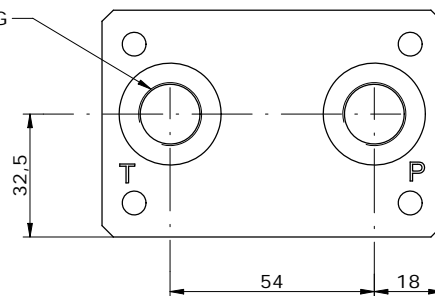

n°2 BSP 3/8G

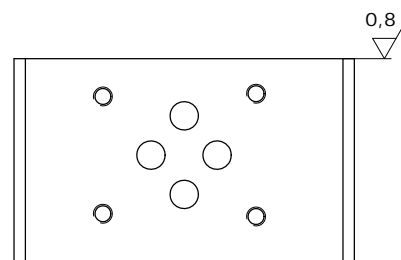
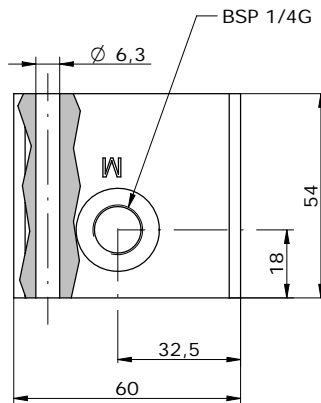
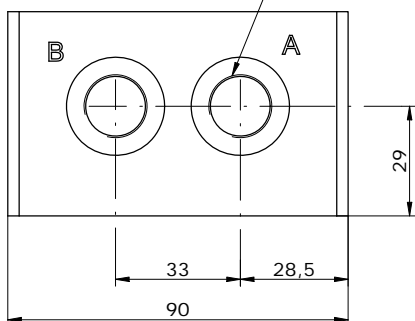

n°2 3/8G

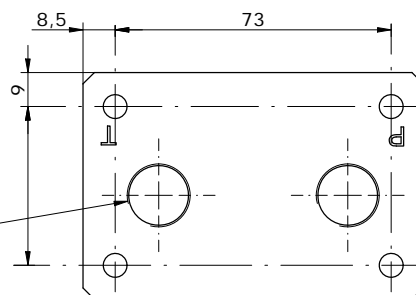

**E\_ 610 - 09 - 38**

**S = STEEL**  
**A = ALUMINIUM**

**PANNELLO MODULARE CETOP 3 PER VALVOLA RIDUTTRICE**  
**MODULAR PLATE CETOP 3 FOR REDUCING VALVE**

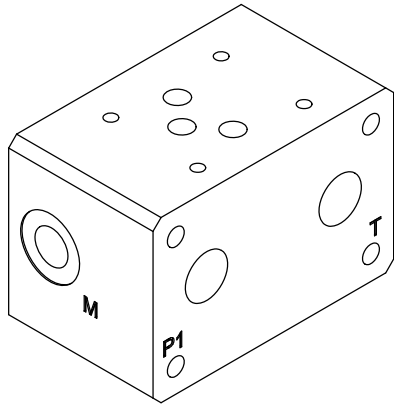

Schema idraulico  
Hydraulic diagram

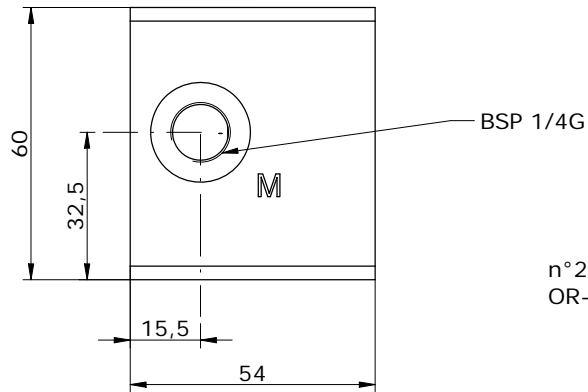
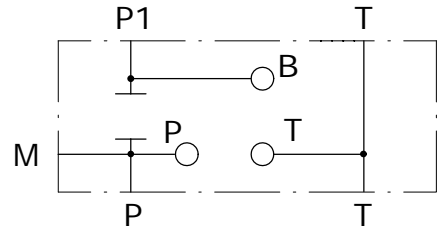

n°2 BSP 3/8G  
OR-2093

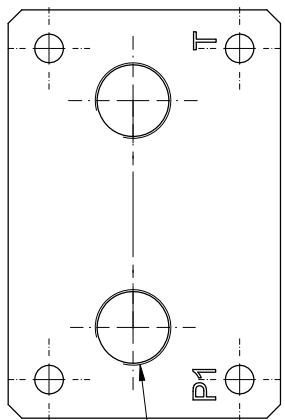
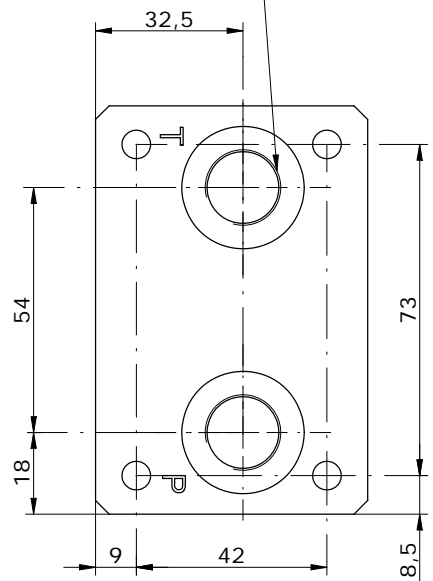

n°2 3/8G

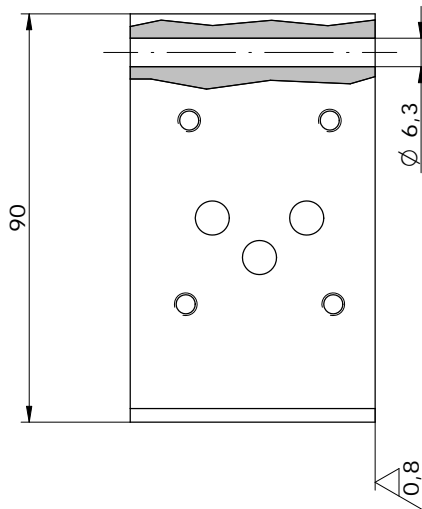

**E\_ 610 - 11**

**S = STEEL**  
**A = ALUMINUM**

**BASE MODULARE CETOP 3 CON VALVOLE ELETTRICHE DI RITEGNO**  
**MODULAR PLATE NG6 WITH ELECTRICAL CHECK VALVES**

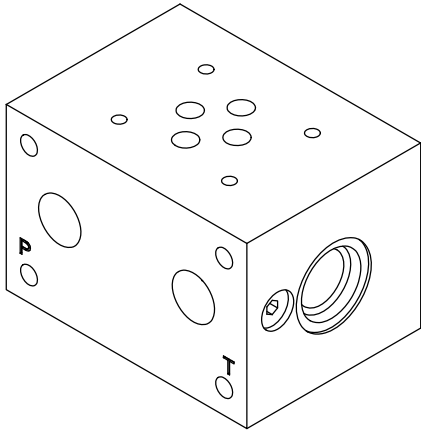

Schema idraulico  
Hydraulic diagram

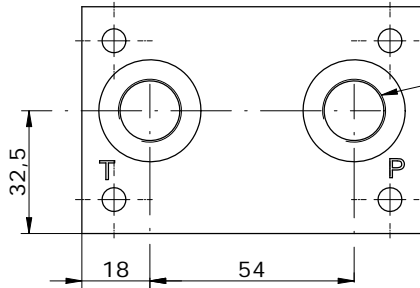
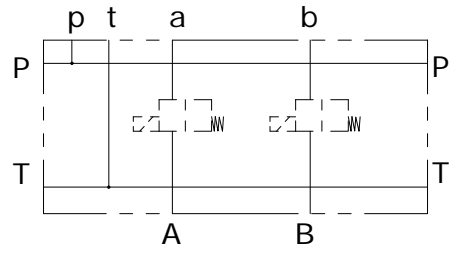

n°2 BSP 3/8G  
OR 2093

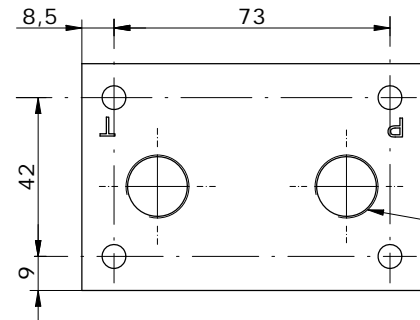
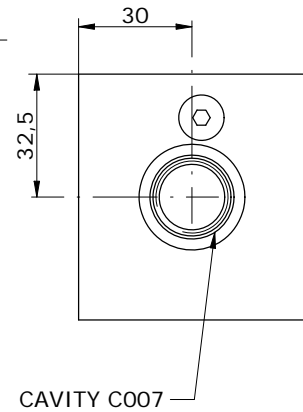
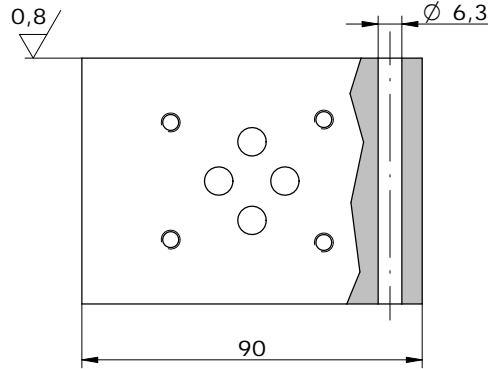
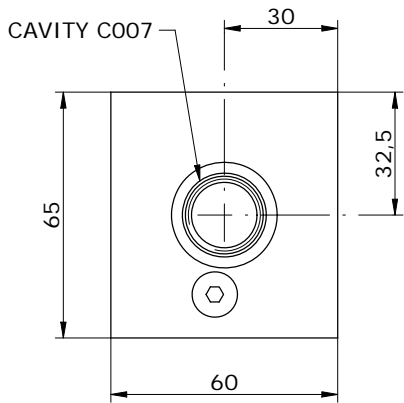

n°2 3/8G

**E\_ 610 - 12 - 38**

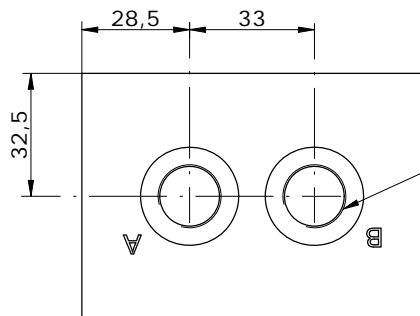

n°2 BSP 3/8G

**BASE MODULARE CETOP 3 CON VALVOLE ELETTRICHE DI RITEGNO**  
**MODULAR PLATE NG6 WITH ELECTRICAL CHECK VALVES**

**01**

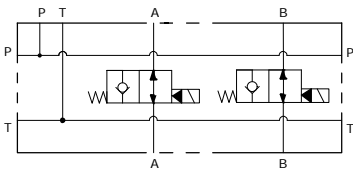

**02**

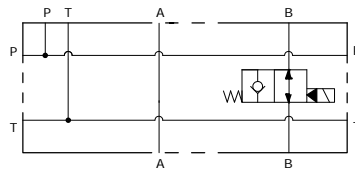

**03**

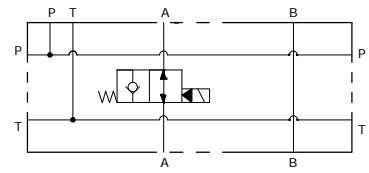

**TS4\***

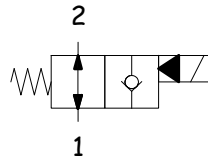
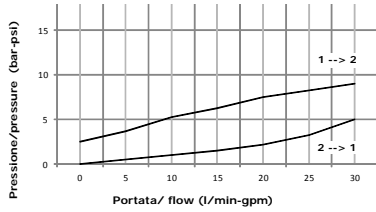

**01**

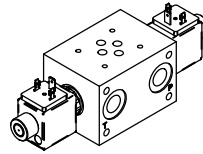

**02**

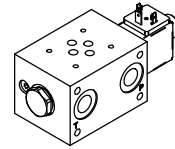

**03**

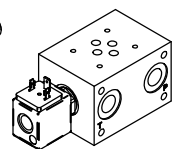

**04**

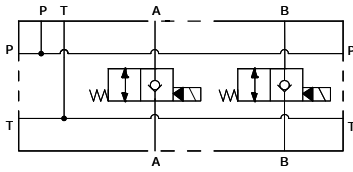

**05**

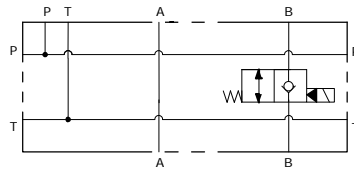

**06**

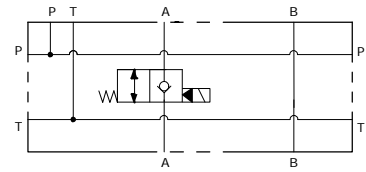

**TS3\***

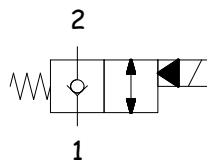
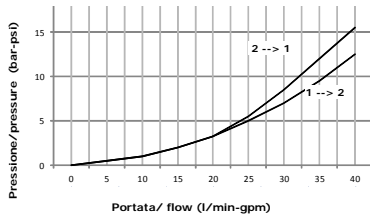

**04**

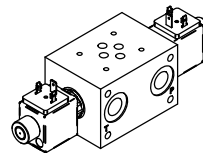

**05**

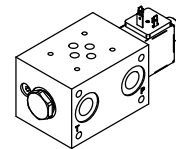

**06**

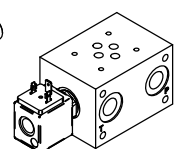

**07**

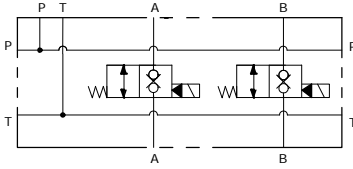

**08**

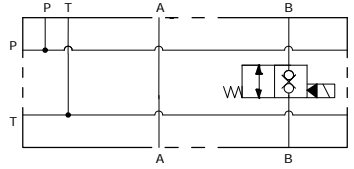

**09**

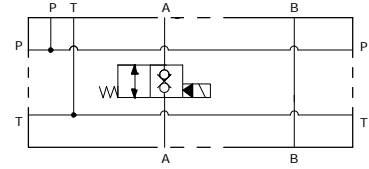

**TD3\***

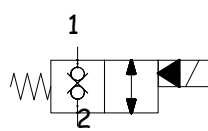
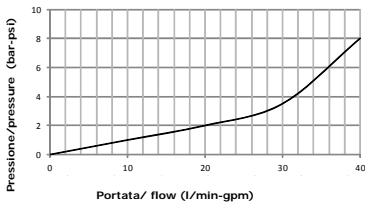

**07**

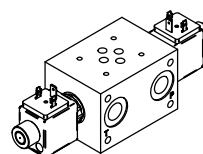

**08**

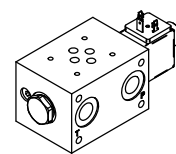

**09**

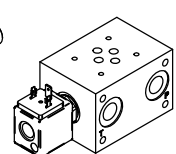

**E\_ 610 - 12 - 38 -**

S = STEEL  
A = ALUMINIUM

SEE SCHEME

N = BUNA  
V = VITON

TD3  
TS3  
TS4

**REGOLAZIONE / REGULATION**

SVCP-S08-TD3	SVCP-S08-TS3	SVCP-08-TS4
3 = PRESSIONE SU SPINA / PUSH PIN	0 = SENZA COMANDO MANUALE / NO MANUAL OVERRIDE	3 = PRESSIONE SU SPINA / PUSH PIN
4 = PRESSIONE SU BOTTONI / PUSH BOTTON	1 = VITE / SCREW	4 = PRESSIONE SU BOTTONI / PUSH BOTTON
	2 = SPINGA E GIRA / PUSH AND TWIST	
	6 = TAPPO PREMUTO / PULL AND HOLD	
	5 = BRUGOLA / ALLEN	

**TENSIONE / VOLTAGE**

000 = SENZA BOBINA / WITHOUT COIL  
 D12 = 12 VDC  
 D24 = 24 VDC  
 D220 = 220 RAC  
 D26 = 26 VDC

**TIPO CONNETTORE / CONNECTOR TYPE**

0 = SENZA BOBINE / WITHOUT COIL  
 C = CAVI / LEADS  
 D = DIN 43650  
 G = DEUTSCH DT04-2P  
 A = AMP JUNIOR

\*see **CARTDRIGE VALVES** catalog

WWW.GPA.BY

**BASE MODULARE CETOP 5 A-B POST. 1/2" BSP PER COLLEGAMENTO IN SERIE**  
**MODULAR PLATE CETOP 5 WITH A-B PORTS BACK 1/2" BSP FOR SERIES CIRCUIT**

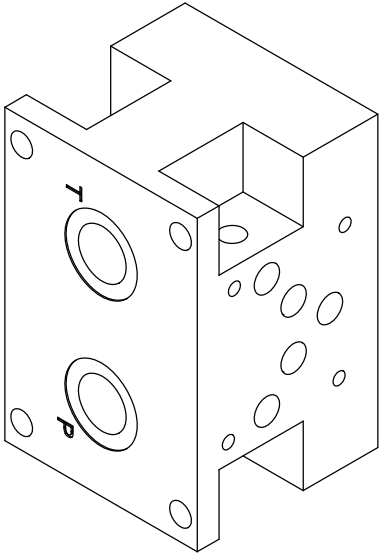

Schema idraulico  
Hydraulic diagram

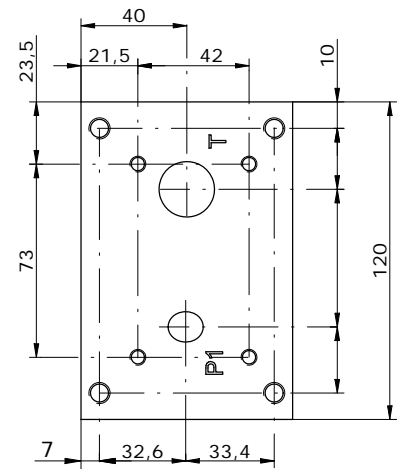
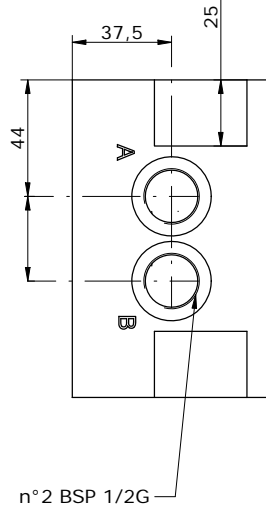
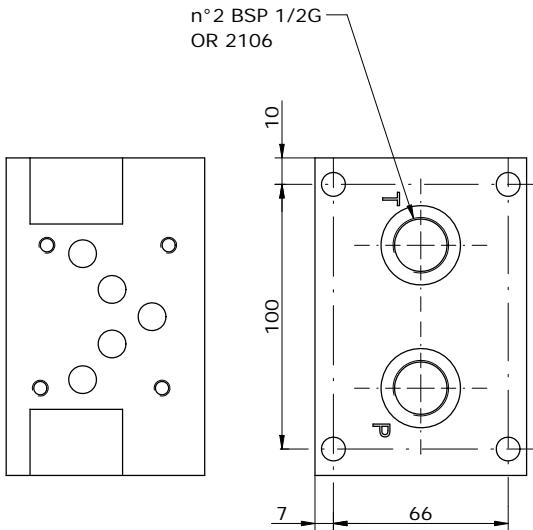
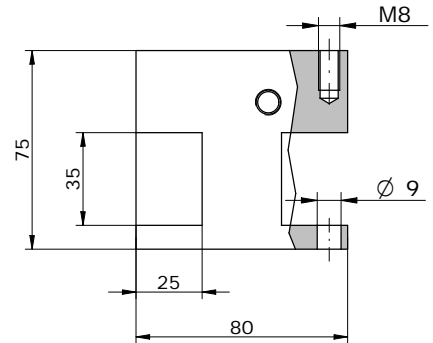
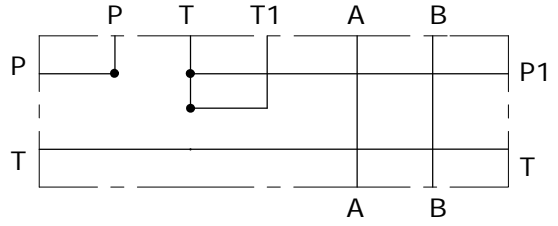

# E\_ 610 - 19 - 12

**S** = STEEL  
**A** = ALUMINUM



**BASE MODULARE CETOP 3 A-B POST. 3/8" BSP PER COLLEGAMENTO IN SERIE**  
**MODULAR PLATE CETOP 3 WITH A-B PORTS BACK 3/8" BSP FOR SERIES CIRCUIT**

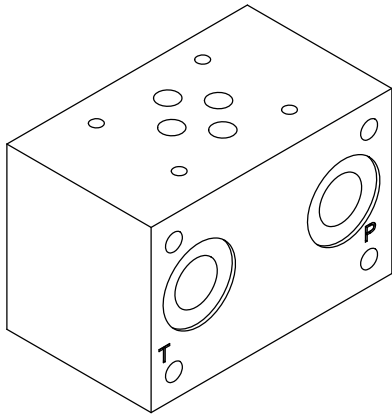

Schema idraulico  
Hydraulic diagram

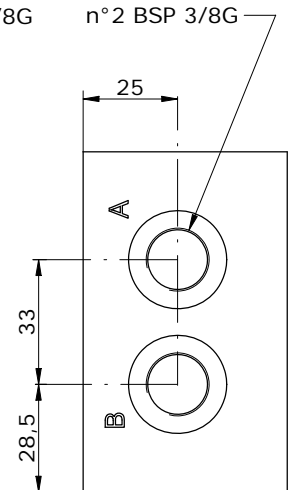
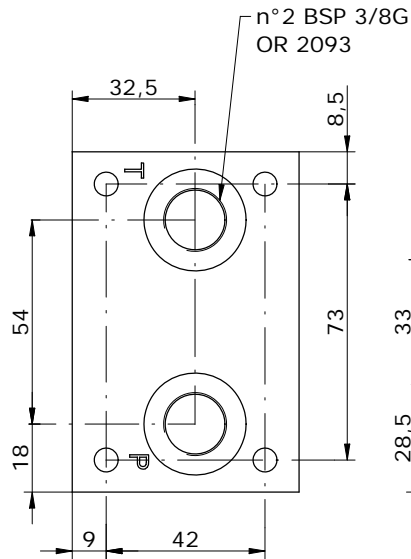
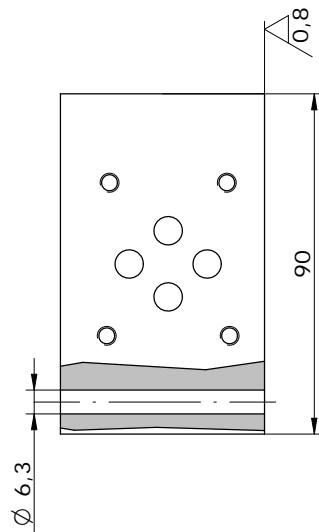
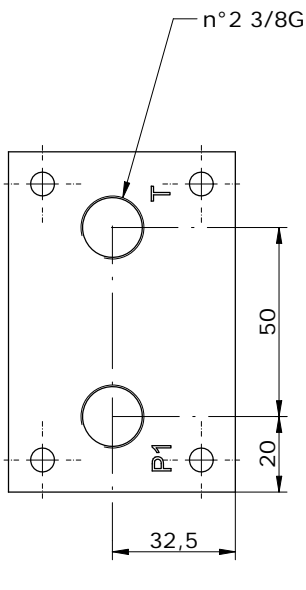
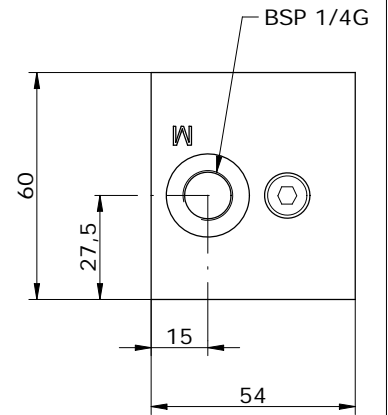
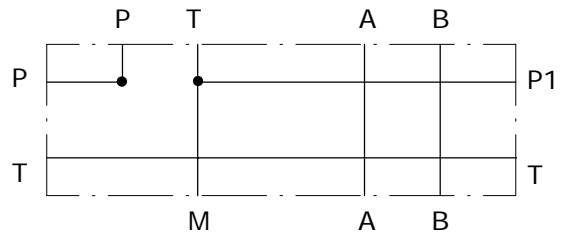

**E\_ 610 - 20 - 38**

**S = STEEL**  
**A = ALUMINUM**

**BASE MODUL. CON INTEGRATA VALV. DI BLOCCO DOPPIA PILOTATA A-B 3/8" BSP  
MODULAR PLATE WITH DOUBLE PILOT OPERATED CHECK VALVE CETOP 3 A-B 3/8" BSP**

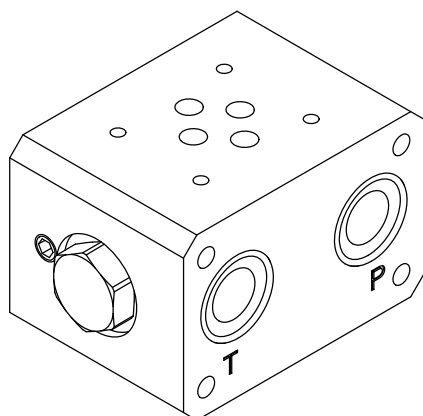

Schema idraulico  
Hydraulic diagram

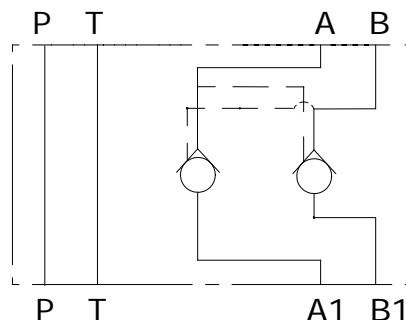

CAVITY C007

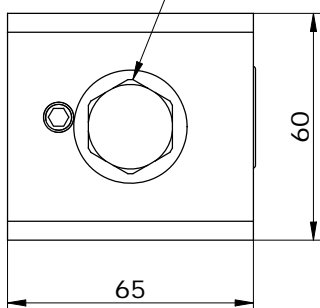

Curva caratteristica

Valori ottenuti con viscosità 16cSt (2.43°E) a 65°C

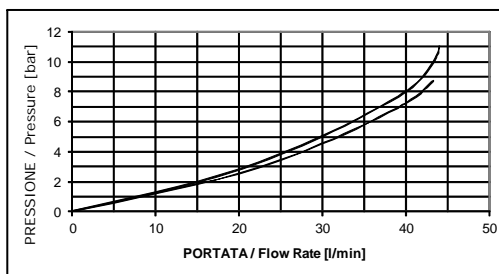

Rapporto di pilotaggio 1:3,5

Ratio Pilot 1:3,5

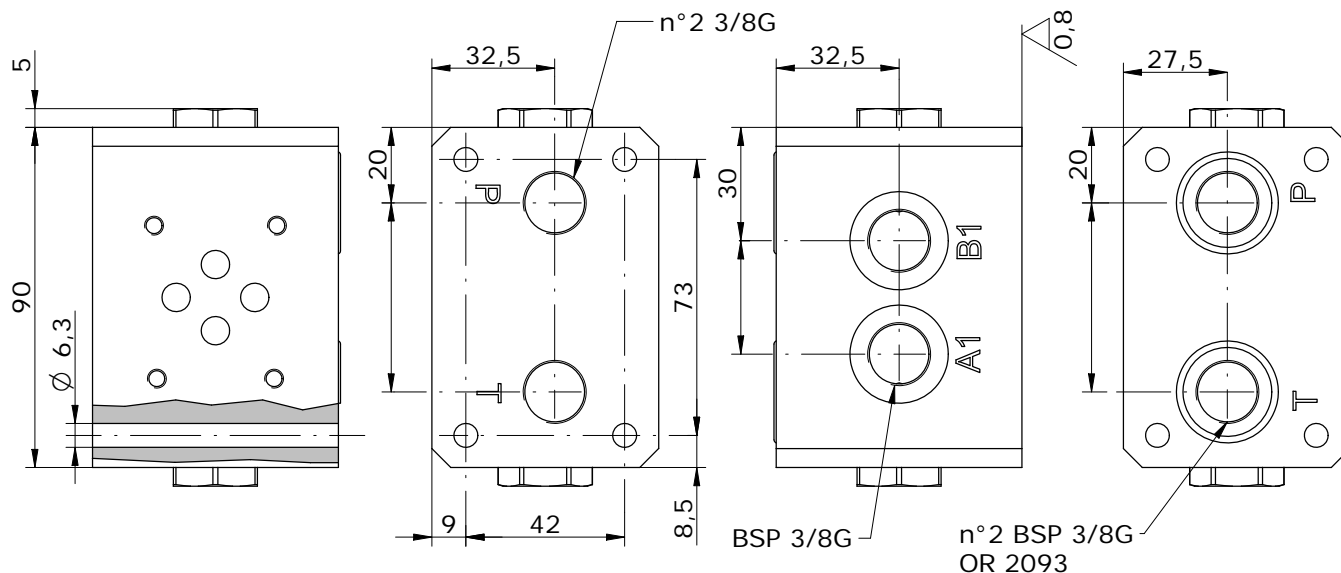

**E\_ 610 - 21 - 38**

S = STEEL  
A = ALUMINUM

**BASE MODULARE CON VALVOLA DI RITEGNO**  
**MODULAR PLATE WITH CHECK VALVE**

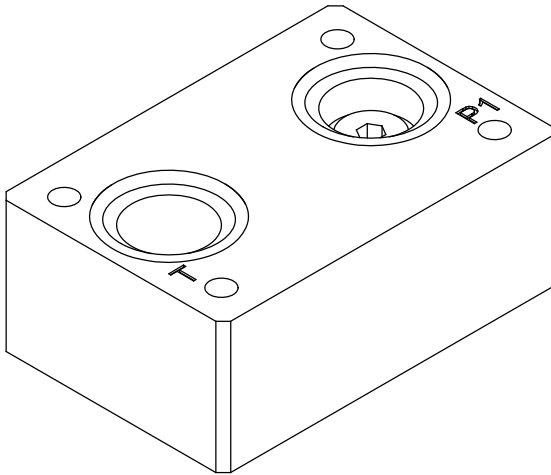

Schema idraulico  
Hydraulic diagram

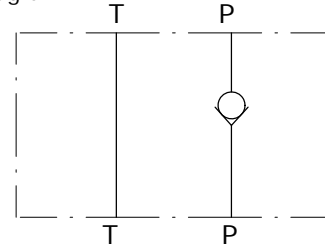

*PRESSURE DROP*

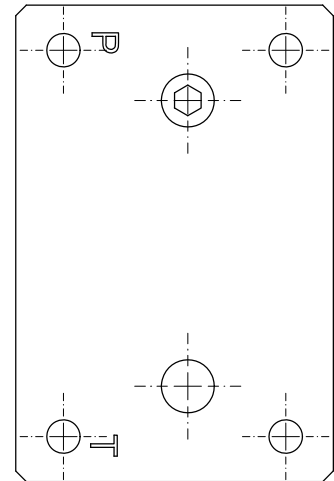
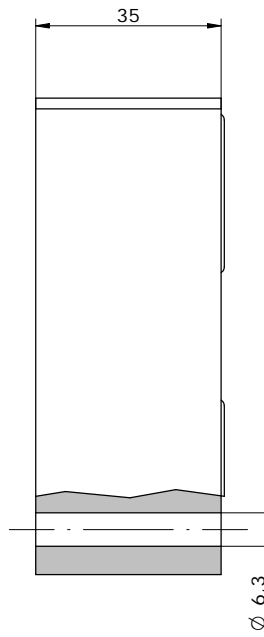
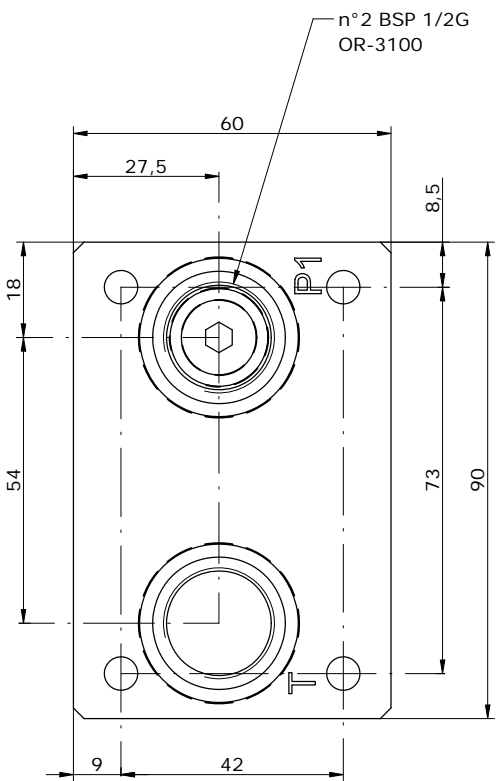
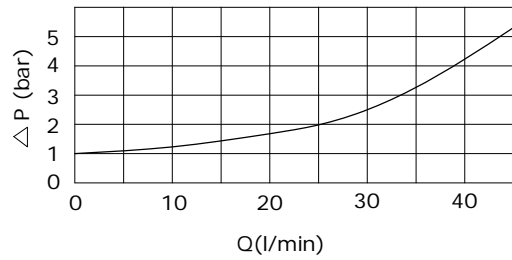

# E\_ 610 - 22

**S** = STEEL  
**A** = ALUMINUM

**PANNELLO MOD. CON REGOLATRICI DI PORTATA UNIDIREZIONALI**  
**MODULAR PLATE NG6 WITH FLOW CONTROL VALVE**

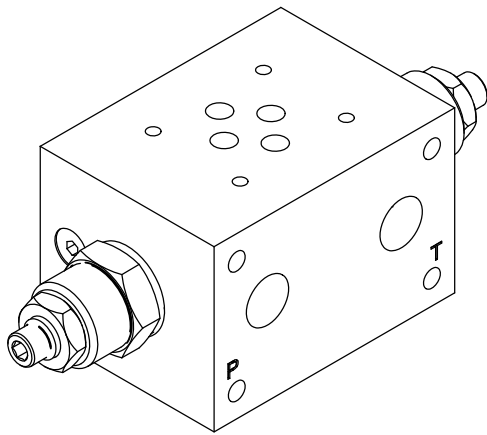

Schema idraulico  
Hydraulic diagram

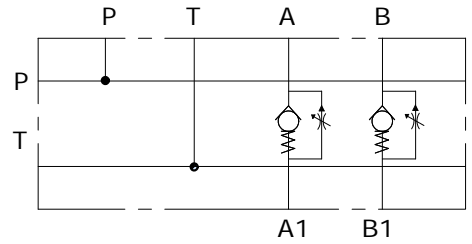

**TIPDI REGOLAZIONE PER V. MAX**  
**REGULATION TYPE FOR RELIEF VALVE**

	<b>H</b>	VITE CON CHIAVE ESAGONALE (standard) HEXAGONAL HEAD SCREW
	<b>K</b>	POMOLO KNOB
	<b>C</b>	FISSA CON CAPPuccio COVER CAP
	<b>I</b>	INVIOLABILE NON ADJUSTABLE

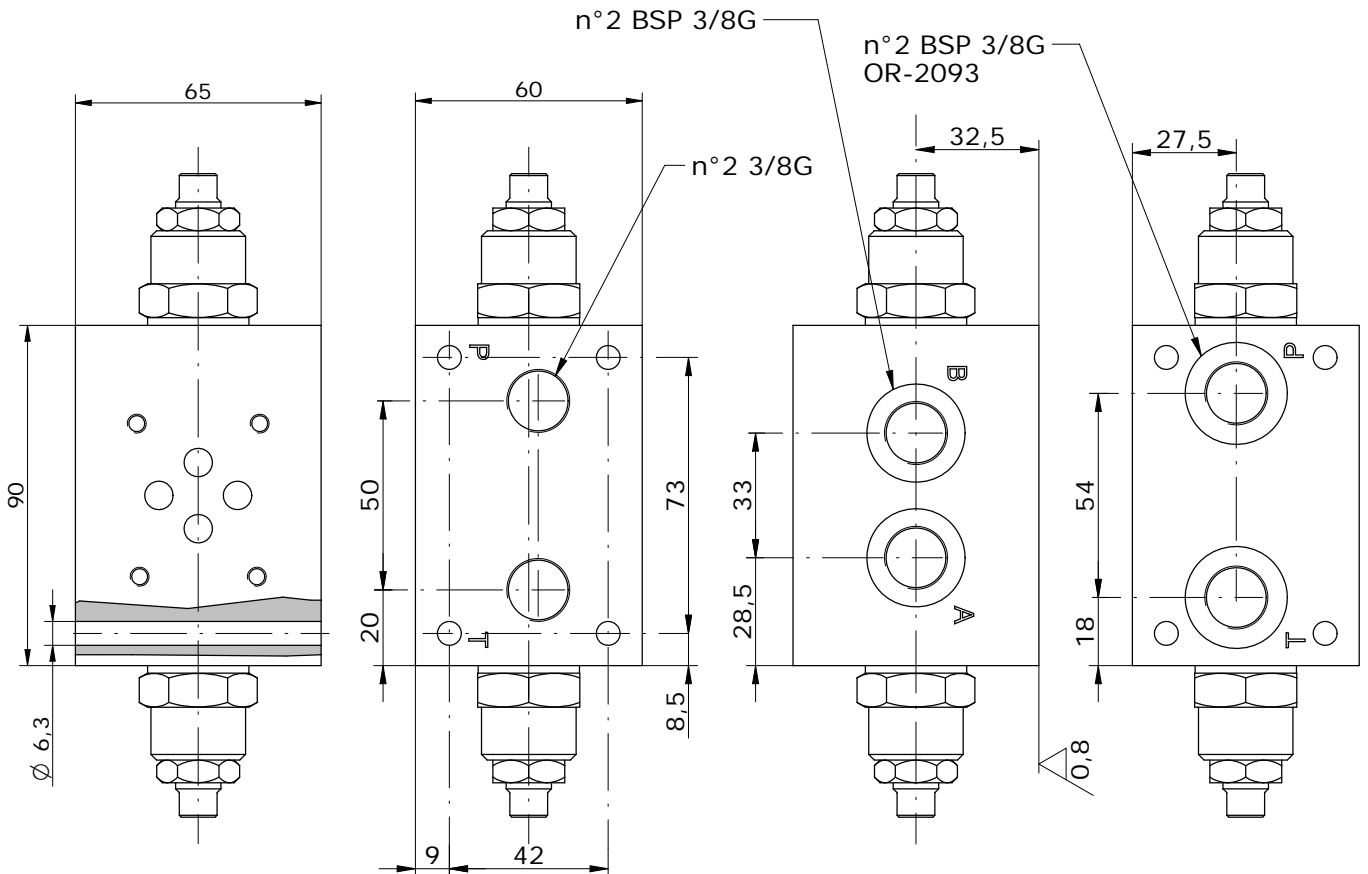

**E\_ 610 - 23 - 38 - \_ - \_**

**S = STEEL**  
**A = ALUMINIUM**

**A = FLOW CONTROL ON PORT A**  
**D = FLOW CONTROL ON PORT A AND B**

**OMETTERE / OMIT**  
**H = HEXAGONAL HEAD SCREW**  
**K = KNOB**  
**C = COVER CAP**  
**I = NOT ADJUSTABLE**

\* see **CARTDRIGE VALVES** catalog

WWW.GPA.BY

**BASE MODUL. CETOP 5 CON VALVOLA REGOL. DI PRESSIONE A-B LAT. 1/2" BSP  
MODULAR PLATE CETOP 5 WITH A-B ON SIDE 1/2" AND RELIEF VALVE**

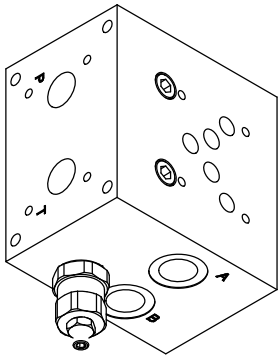

Schema idraulico  
Hydraulic diagram

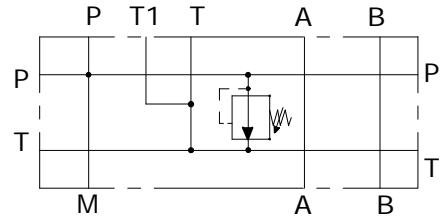

**TIPI DI REGOLAZIONE PER V. MAX  
REGULATION TYPE FOR RELIEF VALVE**

	H	VITE CON CHIAVE ESAGONALE (standard) HEXAGONAL HEAD SCREW
	K	POMOLO KNOB
	C	FISSA CON CAPPUCIO COVER CAP
	I	INVIOLABILE NON ADJUSTABLE

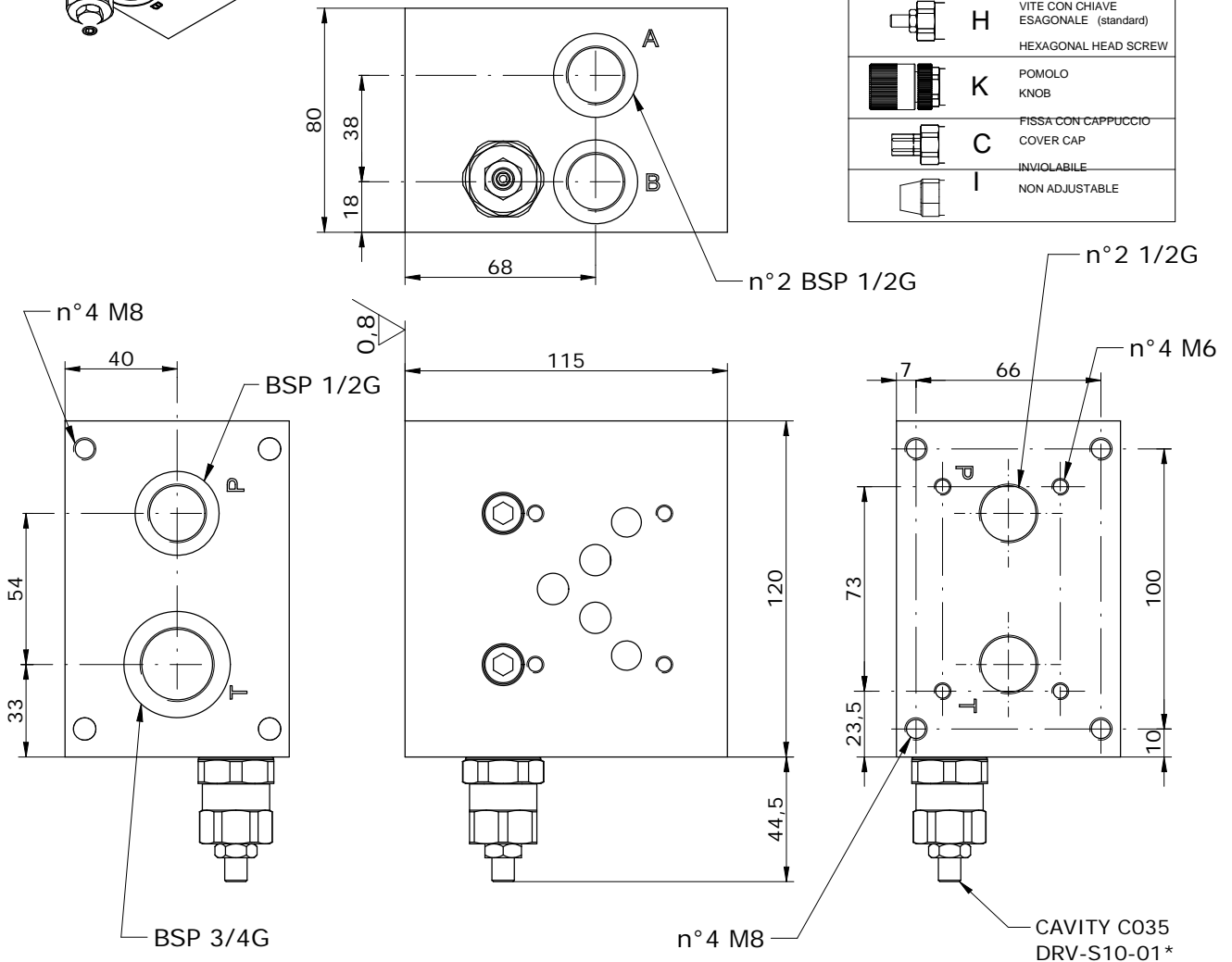

**E\_ 610 - 24 - 12 - \_ - \_**

**S = STEEL  
A = ALUMINUM**

**0 = WITHOUT RELIEF VALVE  
1 = 0-80 bar  
2 = 50-190 bar  
3 = 100-350 bar**

**OMETTERE / OMIT  
H = HEXAGONAL HEAD SCREW  
K = KNOB  
C = COVER CAP  
I = NOT ADJUSTABLE**

\*see **CARTDRIGE VALVES** catalog

WWW.GPA.BY

**PANNELLO MODULARE CETOP 5 A-B LATERALI 1/2" BSP**  
**MODULAR PLATE CETOP 5 WITH A-B PORTS ON SIDE 1/2" BSP**

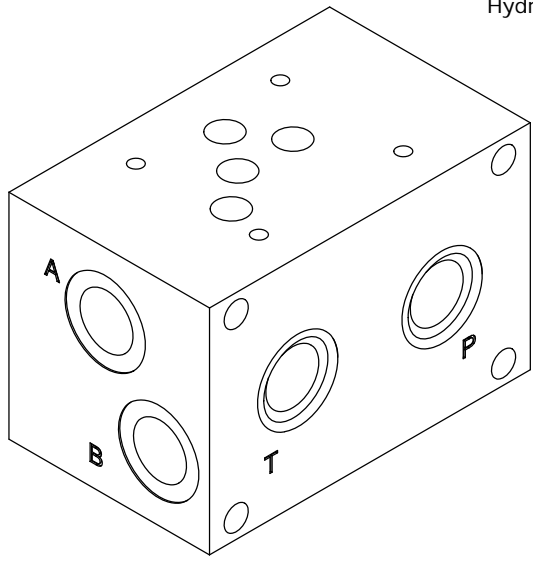

Schema idraulico  
Hydraulic diagram

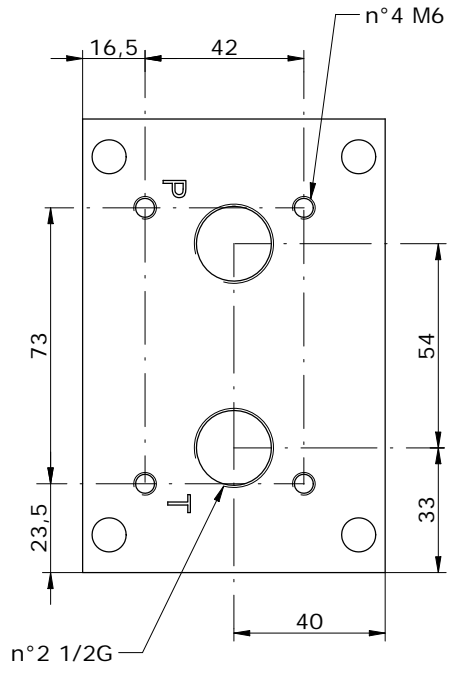
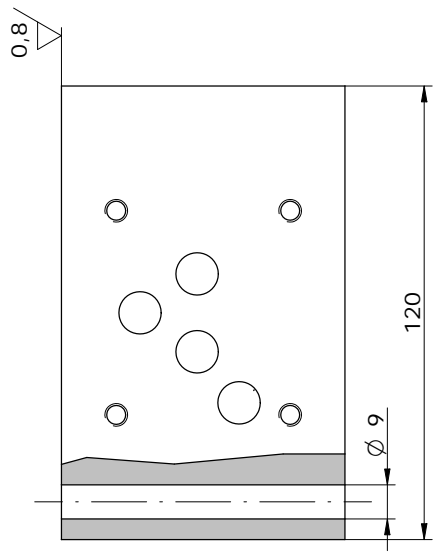
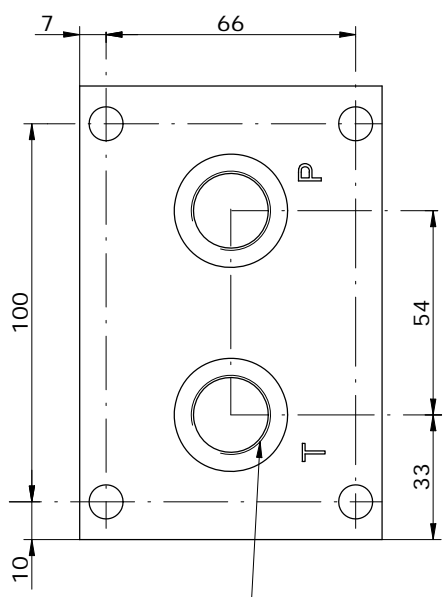
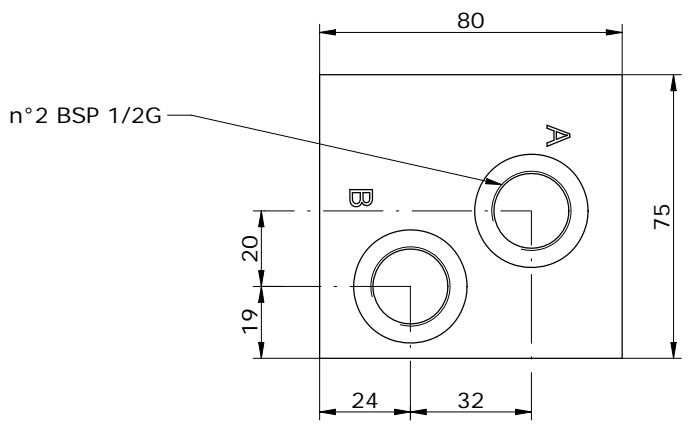
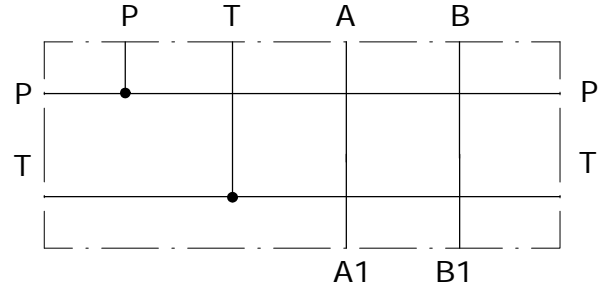

n°2 BSP 1/2G  
OR-3100

**E\_ 610 - 25 - 12**

**S = STEEL**  
**A = ALUMINUM**

**PANNELLO MODULARE CETOP 5 A-B POSTERIORI 3/4" BSP**  
**MODULAR PLATE CETOP 5 WITH A-B PORTS BACK 3/4" BSP**

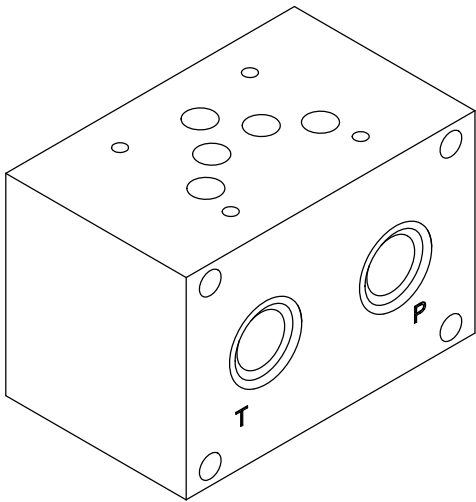
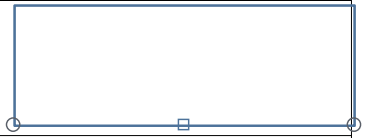

Schema idraulico  
Hydraulic diagram

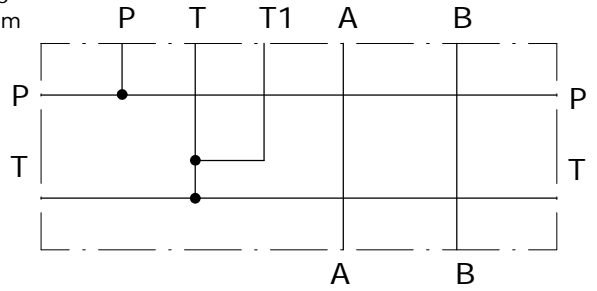

BSP 1/4G

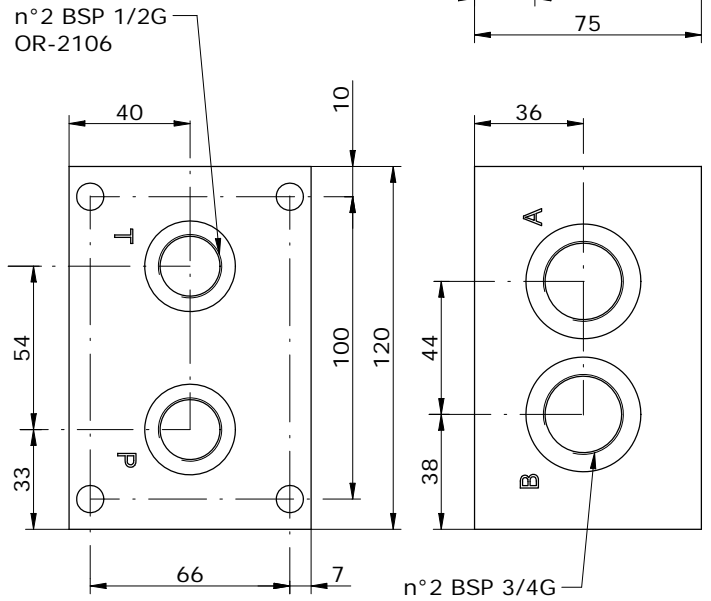
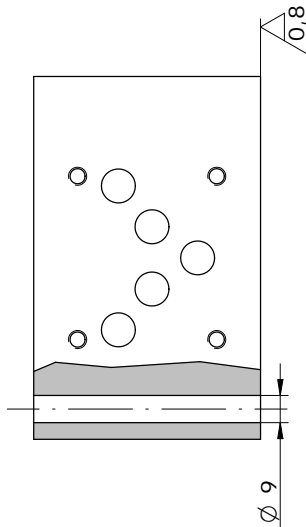
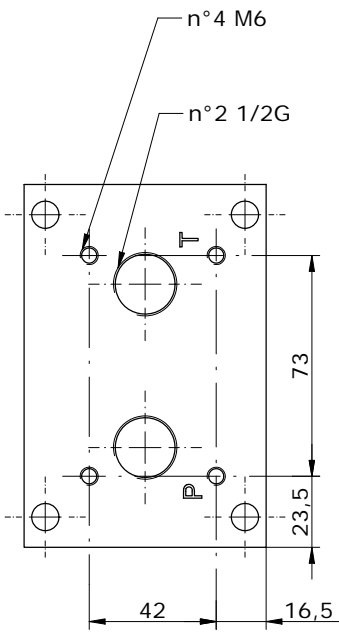
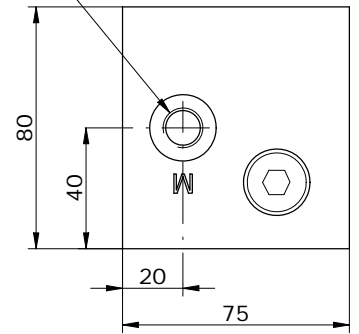

**E\_ 610 - 26 - 34**

**S = STEEL**  
**A = ALUMINUM**

**PANNELLO MODULARE CETOP 3 A-B POSTERIORI 1/2" BSP**  
**MODULAR PLATE CETOP 3 WITH A-B PORTS BACK 1/2" BSP**

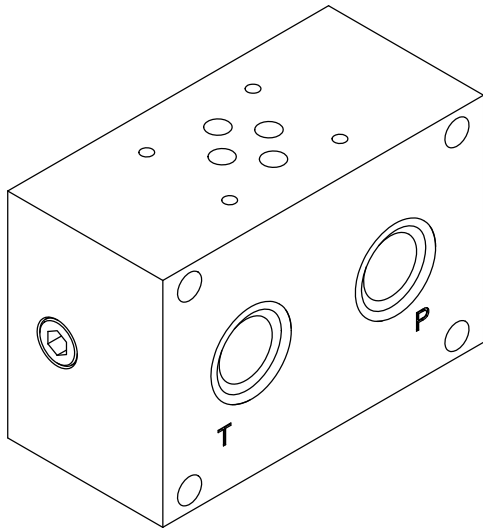

Schema idraulico  
Hydraulic diagram

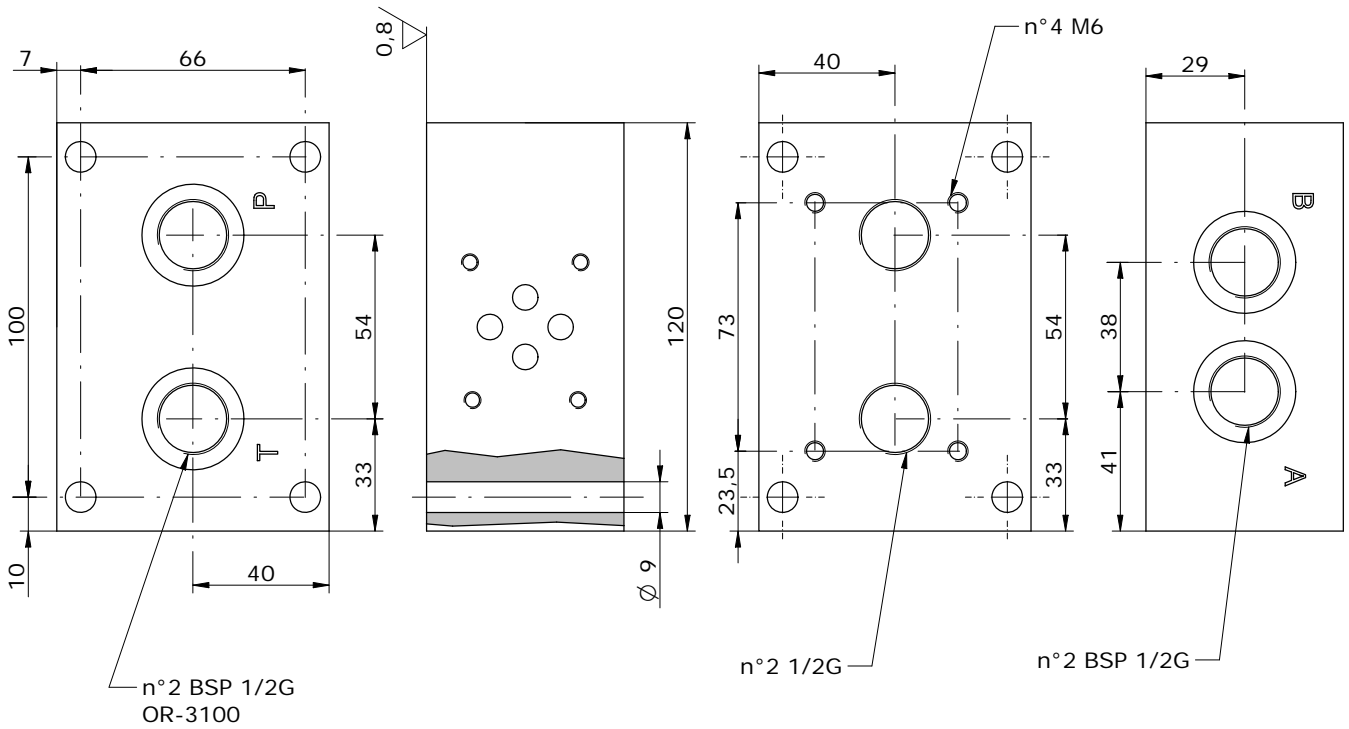
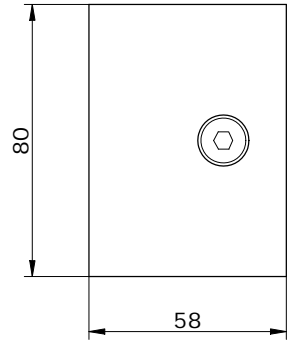
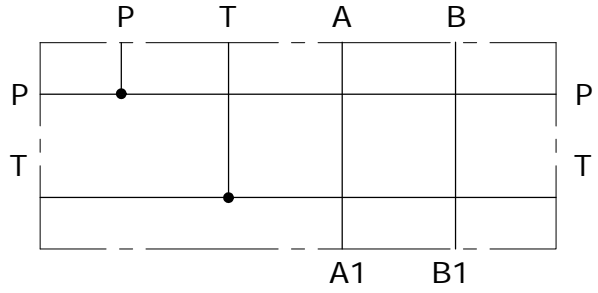

**ES 610 - 27 - 12**

**S = STEEL**  
**A = ALUMINUM**



**PANNELLO MODULARE CETOP 3 A-B LATERALI 3/8" BSP**  
**MODULAR PLATE CETOP 3 WITH A-B PORTS ON SIDE 3/8" BSP**

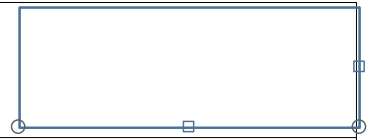

Schema idraulico  
Hydraulic diagram

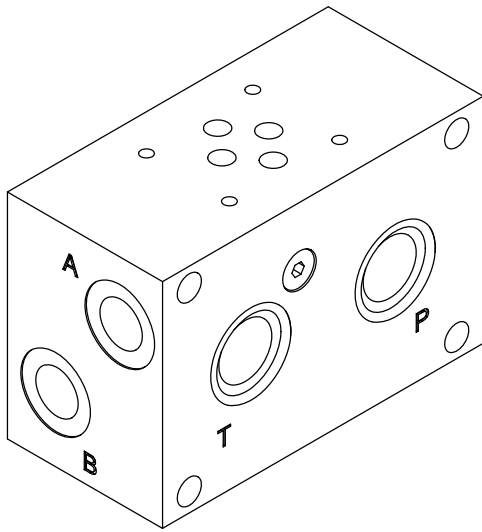
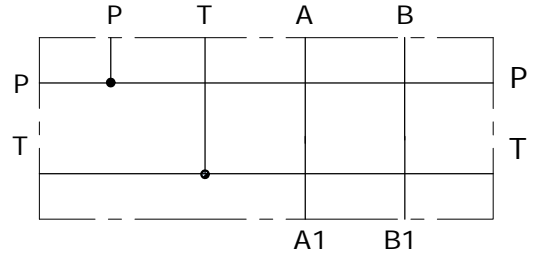

n°2 BSP 3/8G

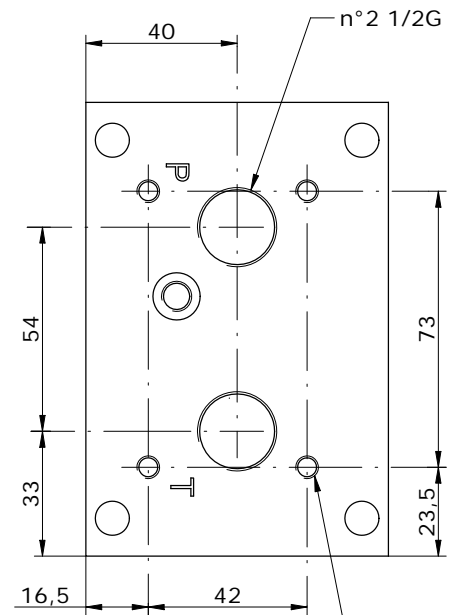
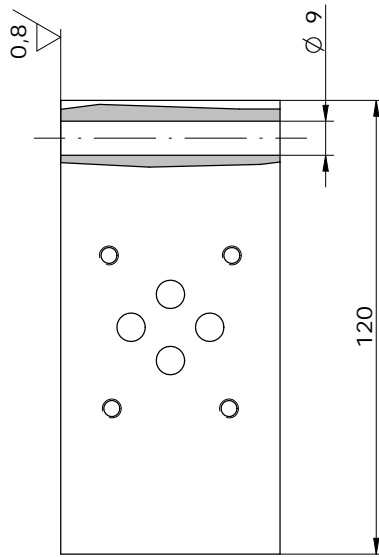
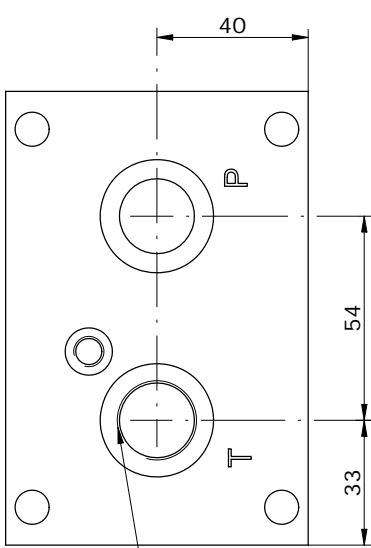
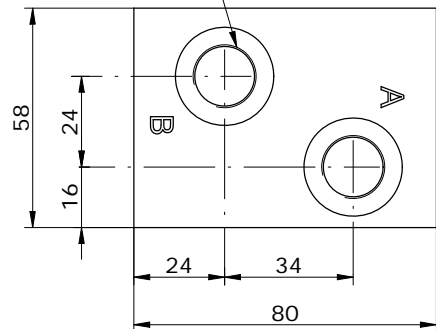

n°2 BSP 1/2G  
OR-3100

n°4 M6

**ES 610 - 28 - 38**

**S** = STEEL  
**A** = ALUMINUM

**BASE MODULARE DI PARTENZA FILETTATA P 1/2" T 3/4" BSP**  
**STARTING PLATE P 1/2" T 3/4" BSP**

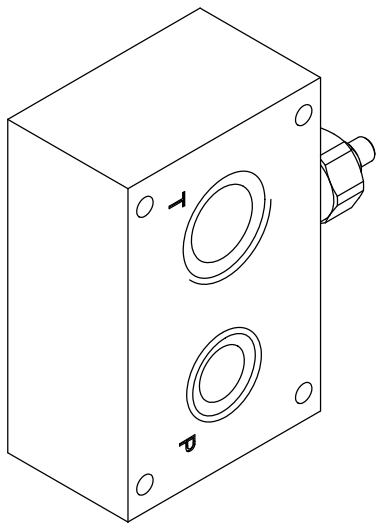

Schema idraulico  
Hydraulic diagram

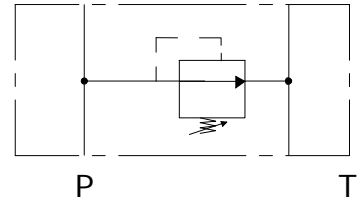

**TIPI DI REGOLAZIONE PER V. MAX**  
**REGULATION TYPE FOR RELIEF VALVE**

	<b>H</b>	VITE CON CHIAVE ESAGONALE (standard) HEXAGONAL HEAD SCREW
	<b>K</b>	POMOLO KNOB
	<b>C</b>	FISSA CON CAPPUCCIO COVER CAP
	<b>I</b>	INVIOLABILE NON ADJUSTABLE

**\* PER LA DRV-S10-02 SONO DISPONIBILE SOLO LA VERSIONE "H" E "I".**  
**FOR DRV-S10-02 IS ONLY AVAILABLE "H" AND "I" VERSIONS.**

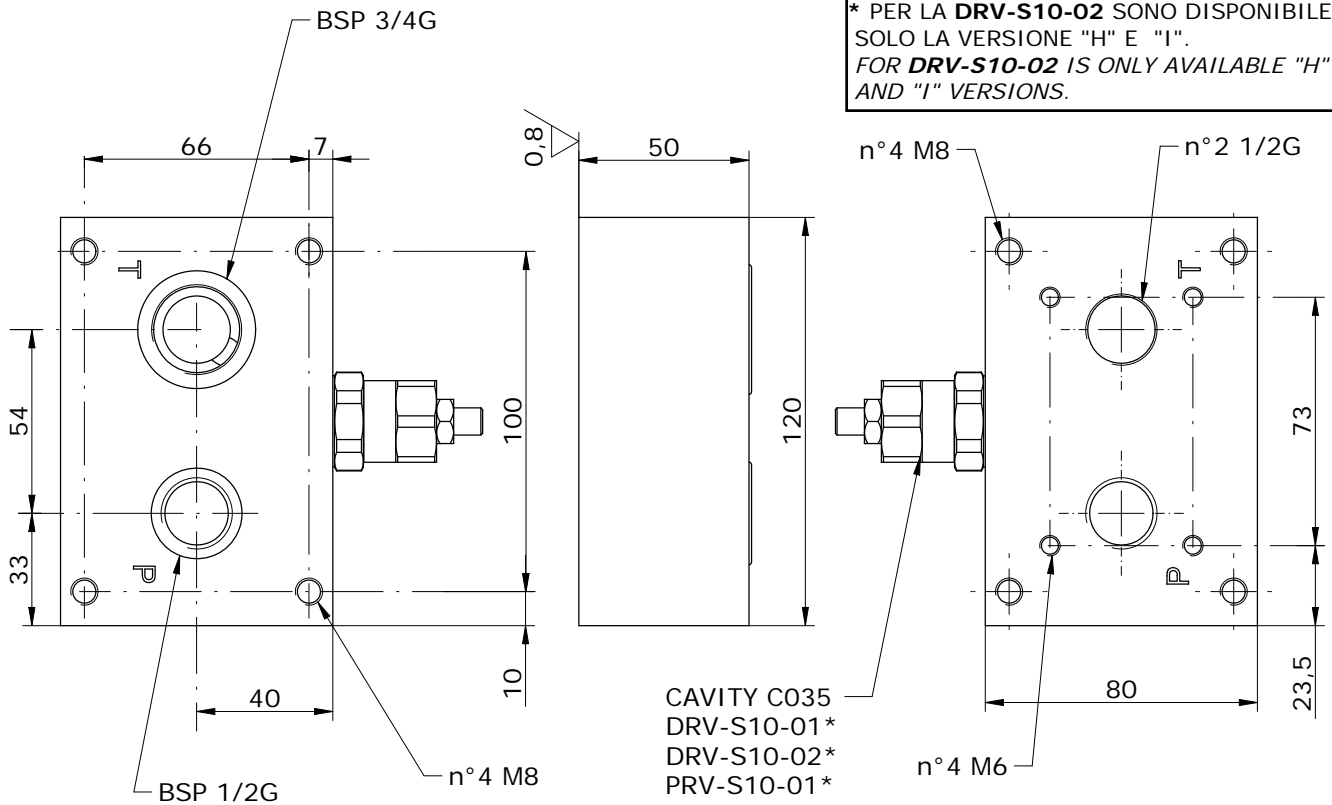

**E\_ 610 - 29 - - - -**

**S** = STEEL  
**A** = ALUMINIUM

**0** = WITHOUT RELIEF VALVE  
**1** = WITH DIRECT R.V. - DRV-S10-01  
**2** = WITH DIRECT R.V. - DRV-S10-02  
**3** = WITH PILOT R.V. - PRV-S10-01  
**4** = RELIEF VALVE READY

**OMETTERE / OMIT**  
**H** = HEXAGONAL HEAD SCREW  
**K** = KNOB  
**C** = COVER CAP  
**I** = NOT ADJUSTABLE

DIRECT R.V. - DRV-S10-01	DIRECT R.V. - DRV-S10-02	PILOT R.V. - PRV-S10-01
<b>0</b> = WITHOUT	<b>0</b> = WITHOUT	<b>0</b> = WITHOUT
<b>1</b> = 0-80 bar	<b>1</b> = 5-75 bar	<b>1</b> = up to 140 bar
<b>2</b> = 50-190 bar	<b>2</b> = 75-125 bar	<b>2</b> = up to 280 bar
<b>3</b> = 100-350	<b>3</b> = 125-220 bar	<b>3</b> = up to 420 bar
	<b>4</b> = 220-350 bar	

\*see **CARTDRIGE VALVES** catalog

**ELEMENTO COMPONENTE CETOP 5, A-B POSTERIORI 1/2" BSP  
MODULAR PLATE FOR PACKING CETOP 5, A-B 1/2" BSP BACK**

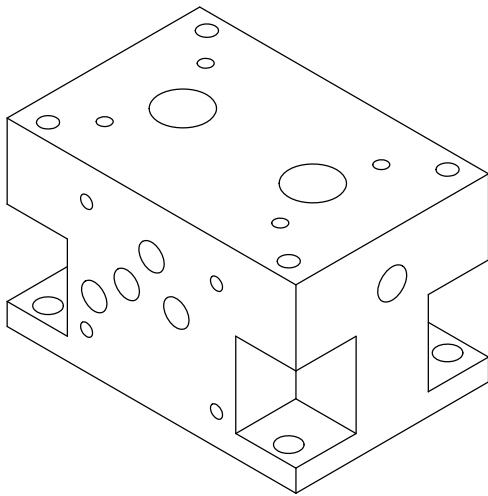
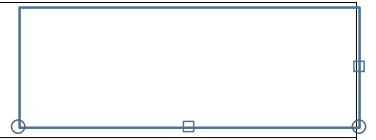

Schema idraulico  
Hydraulic diagram

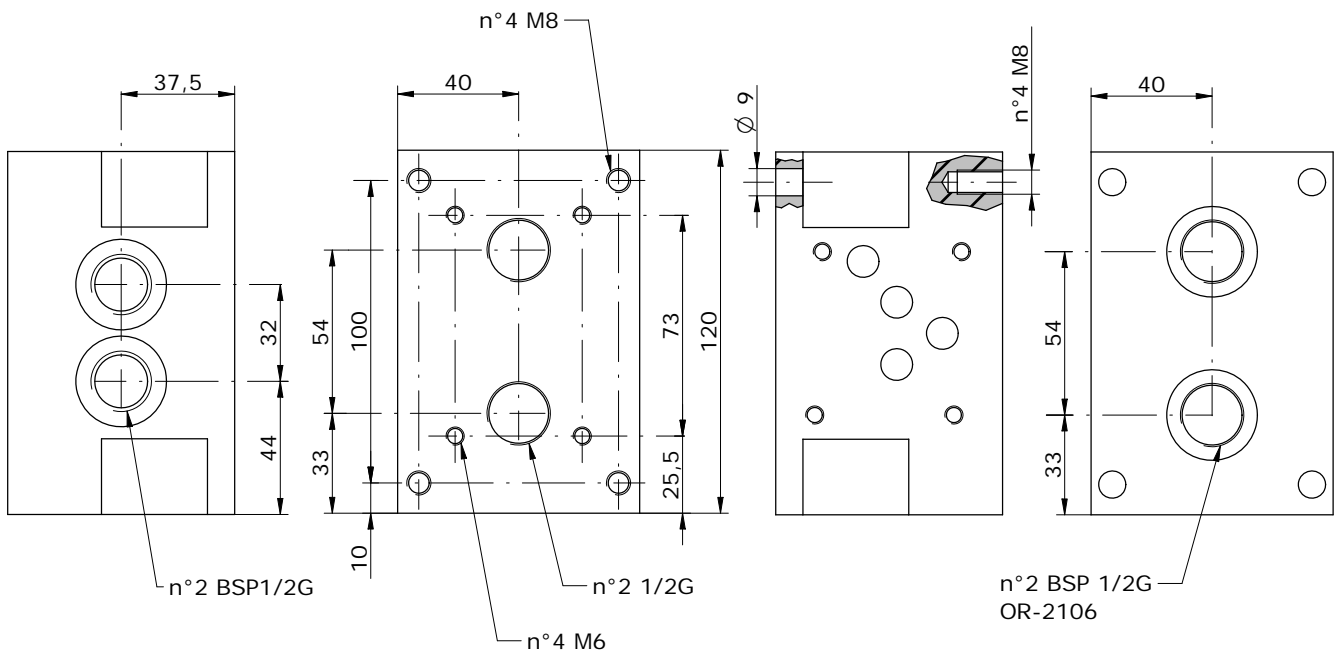
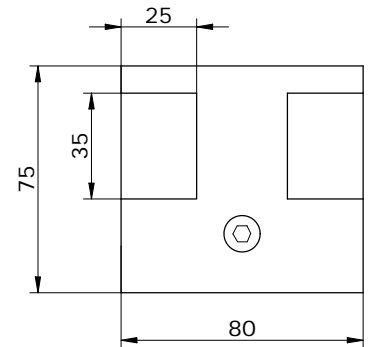
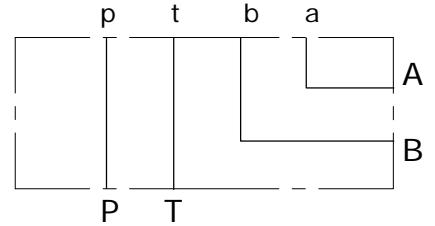

**E\_ 610 - 30 - 12**

**S = STEEL**  
**A = ALUMINUM**

**PANNELLO MODULARE CETOP 3 ALTA - BASSA PRESSIONE A-B POSTERIORI 3/8" BSP**  
**MODULAR PLATE CETOP 3 HIGH - LOW PRESSURE WITH A-B PORTS BACK 3/8" BSP**

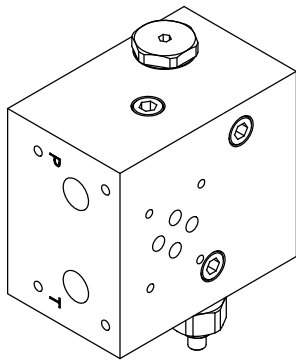

Schema idraulico  
Hydraulic diagram

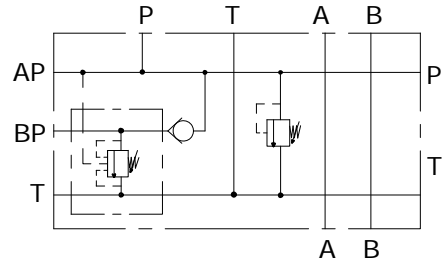

**TIPI DI REGOLAZIONE PER V. MAX**  
**REGULATION TYPE FOR RELIEF VALVE**

	<b>H</b>	VITE CON CHIAVE ESAGONALE (standard) HEXAGONAL HEAD SCREW
	<b>K</b>	POMOLO KNOB
	<b>C</b>	FISSA CON CAPPUCCIO COVER CAP
	<b>I</b>	INVIOLEBBILE NON ADJUSTABLE

**\* PER LA DRV-S10-02 SONO DISPONIBILE SOLO LA VERSIONE "H" E "I".**  
**FOR DRV-S10-02 IS ONLY AVAILABLE "H" AND "I" VERSIONS.**

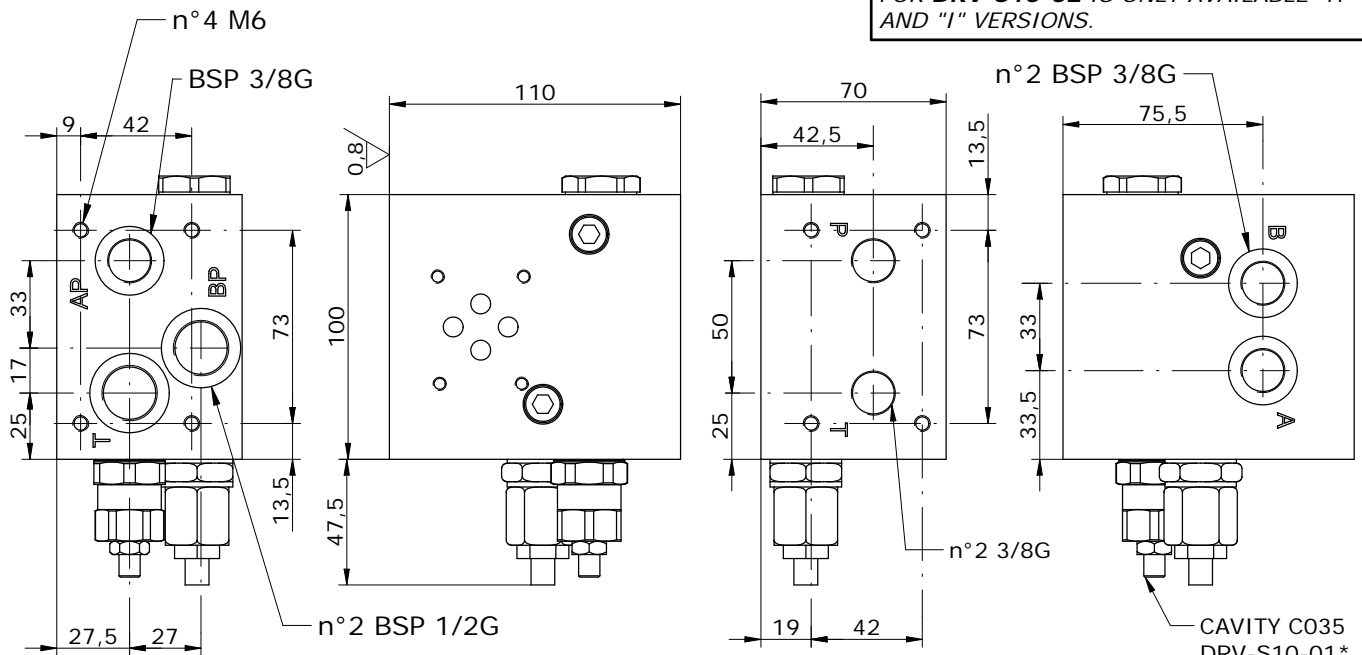
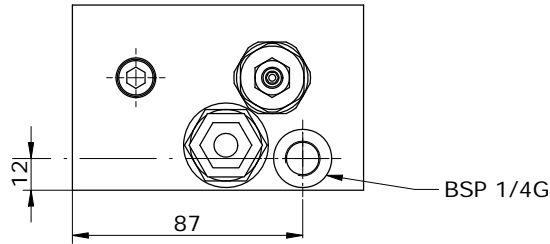

**E\_ 610-31-38- - - -**

**S = STEEL**  
**A = ALUMINIUM**

**LOW PRESSURE SETTINGS:**

- 45 = 45 BAR MAX**
- 60 = 60 BAR MAX**
- 100 = 100 BAR MAX**

**HIGH PRESSURE REGULATION**

- H = HEXAGONAL HEAD SCREW**
- K = KNOB**
- C = COVER CAP**
- I = NOT ADJUSTABLE**

**HIGH PRESSURE SETTINGS:**

DIRECT RELIEF VALVE DRV-S10-01	DIRECT RELIEF VALVE DRV-S10-02 *	PILOT RELIEF VALVE PRV-S10-01
<b>01</b> = 0-80 bar	<b>04</b> = 5-75 bar	<b>08</b> = up to 140 bar
<b>02</b> = 50-190 bar	<b>05</b> = 75-125 bar	<b>09</b> = up to 280 bar
<b>03</b> = 100-350 bar	<b>06</b> = 125-220 bar	<b>10</b> = up to 420 bar
	<b>07</b> = 220-350 bar	

\*see **CARTDRIGE VALVES** catalog

## Diagramma valvola di esclusione BP

*Performance low pressure valve*

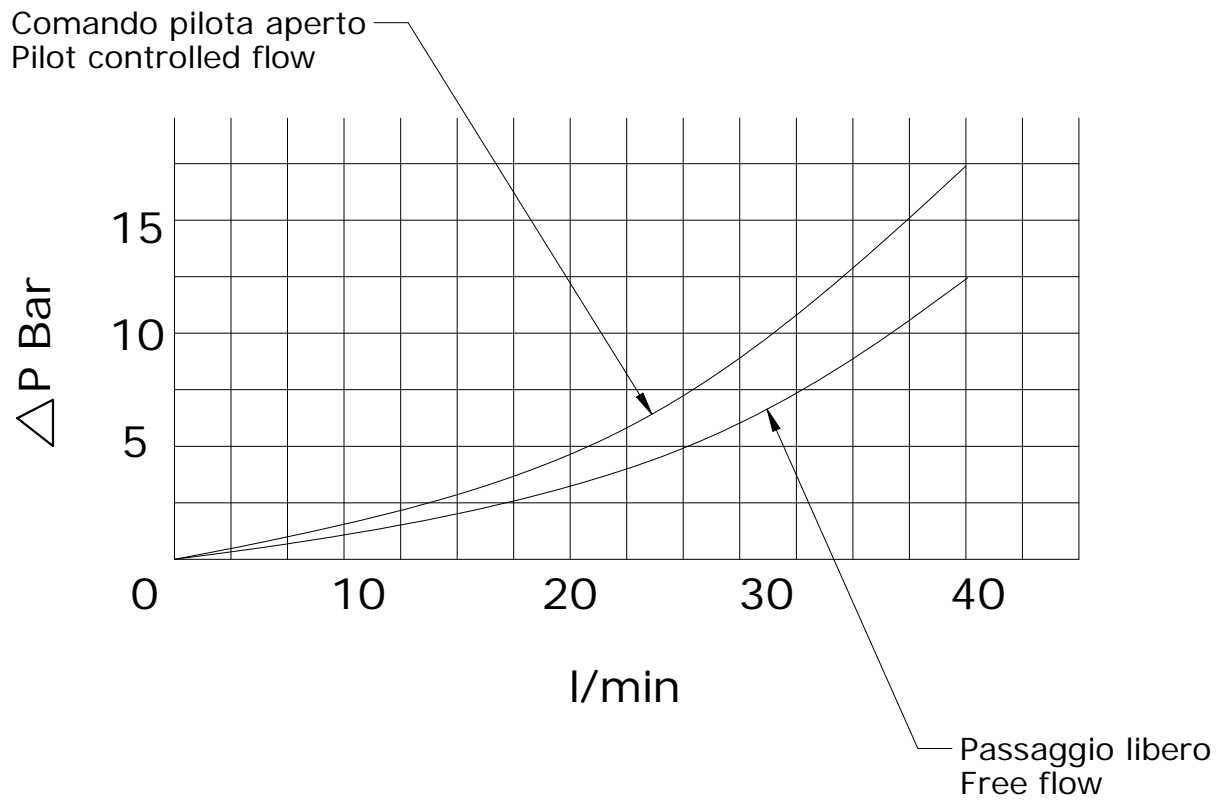

**PANNELLO MODULARE CETOP 5 ALTA - BASSA PRESSIONE A-B POSTERIORI 3/4" BSP**  
**MODULAR PLATE CETOP 5 HIGH - LOW PRESSURE WITH A-B PORTS BACK 3/4" BSP**

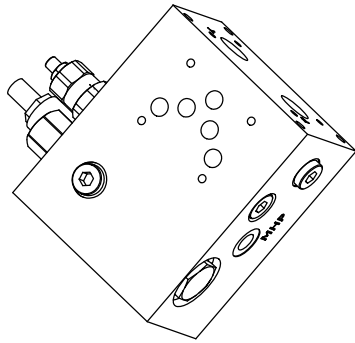

Schema idraulico  
Hydraulic diagram

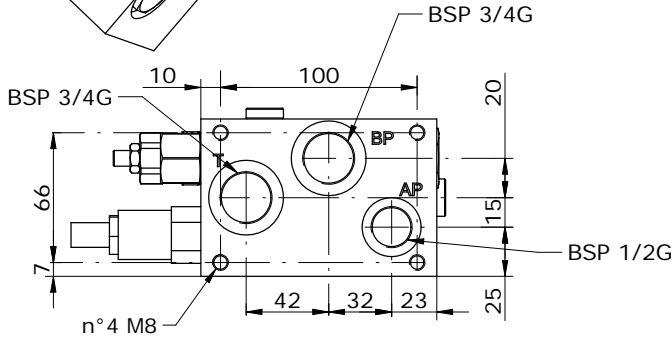
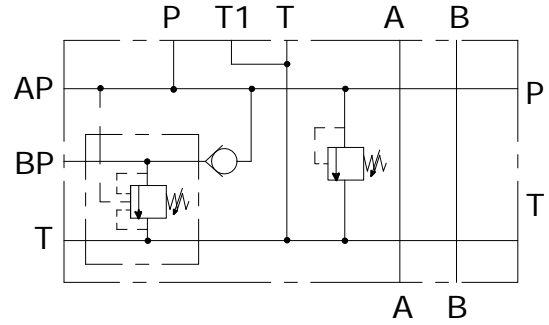

CAVITY C035  
 DRV-S10-01  
 DRV-S10-02  
 PRV-S10-01

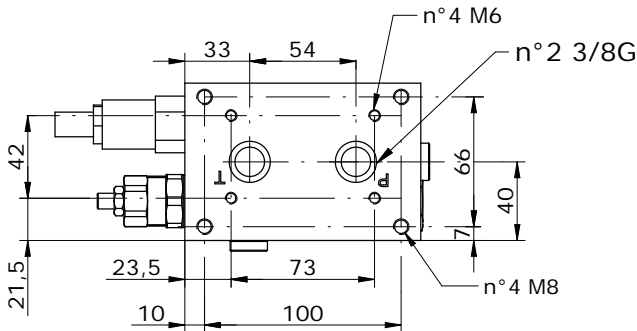
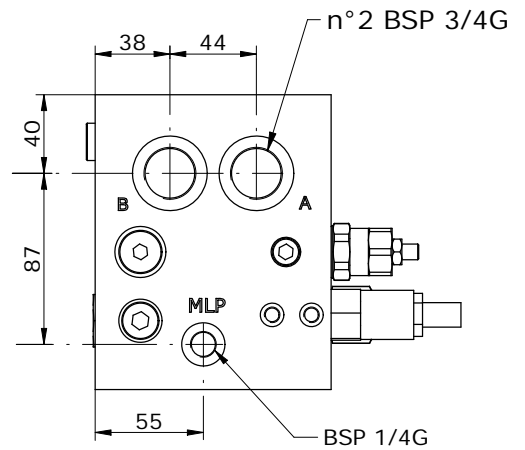
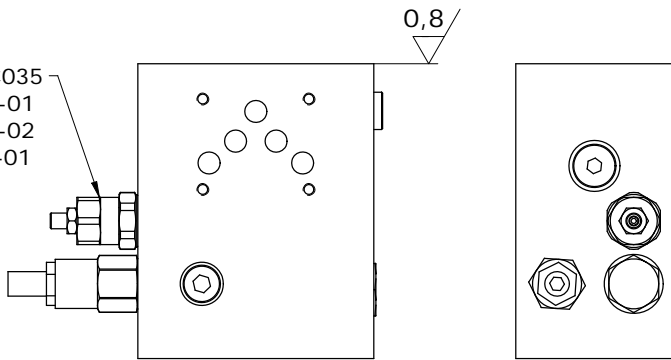

TIPI DI REGOLAZIONE PER V. MAX  
 REGULATION TYPE FOR RELIEF VALVE

	H	VITE CON CHIAVE ESAGONALE (standard) HEXAGONAL HEAD SCREW
	K	POMOLO KNOB
	C	FISSA CON CAPPUCCIO COVER CAP
	I	INVOLABILE

\* PER LA DRV-S10-02 SONO DISPONIBILI SOLO LA VERSIONE "H" E "I".  
 FOR DRV-S10-02 IS ONLY AVAILABLE "H" AND "I" VERSIONS.

**E\_ 610 - 32 - 34 - - - -**

S = STEEL  
 A = ALUMINIUM

LOW PRESSURE SETTINGS:

- 45 = 45 BAR MAX
- 60 = 60 BAR MAX
- 100 = 100 BAR MAX

HIGH PRESSURE REGULATION

- H = HEXAGONAL HEAD SCREW
- K = KNOB
- C = COVER CAP
- I = NOT ADJUSTABLE

HIGH PRESSURE SETTINGS:

DIRECT RELIEF VALVE DRV-S10-01	DIRECT RELIEF VALVE DRV-S10-02*	PILOT RELIEF VALVE PRV-S10-01
01 = 0-80 bar	04 = 5-75 bar	08 = up to 140 bar
02 = 50-190 bar	05 = 75-125 bar	09 = up to 280 bar
03 = 100-350 bar	06 = 125-220 bar	10 = up to 420 bar
	07 = 220-350 bar	

\*see *CARTDRIGE VALVES* catalog

## Diagramma valvola di esclusione BP

*Performance low pressure valve*

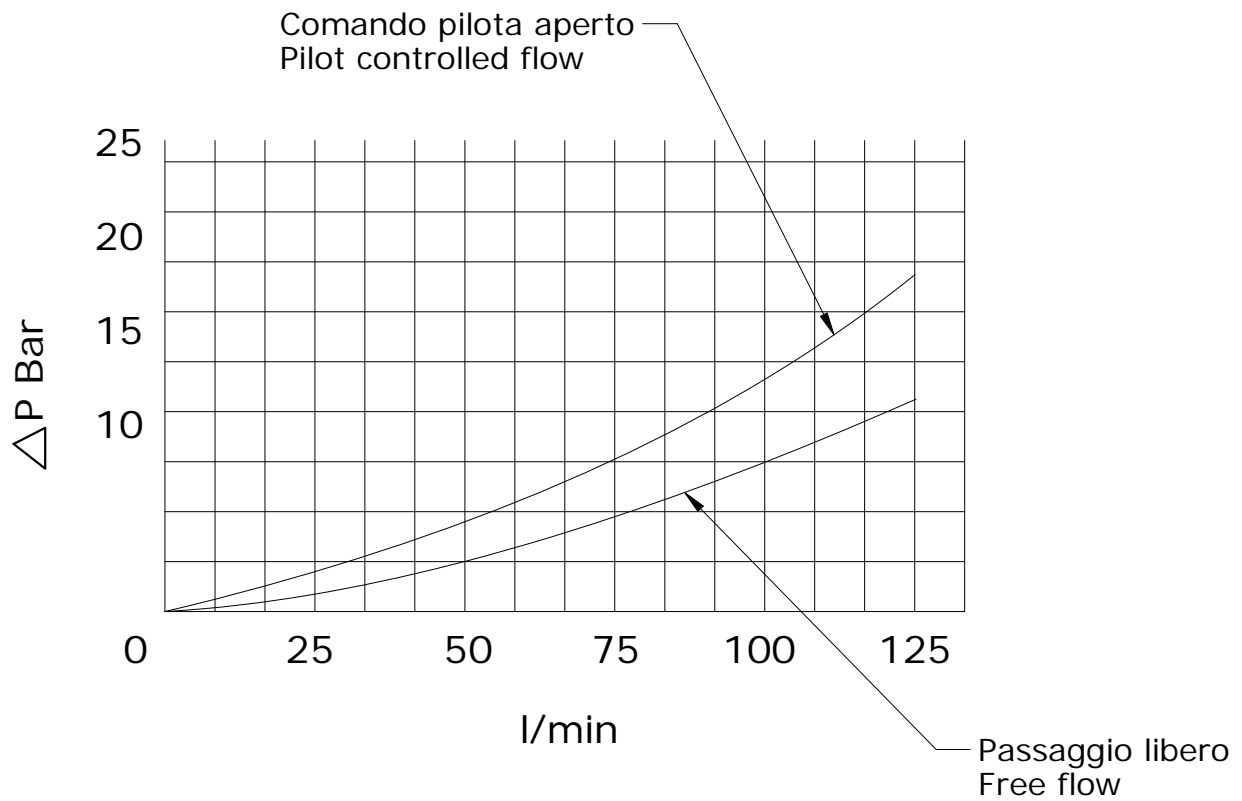

# CAVITY

**C007**

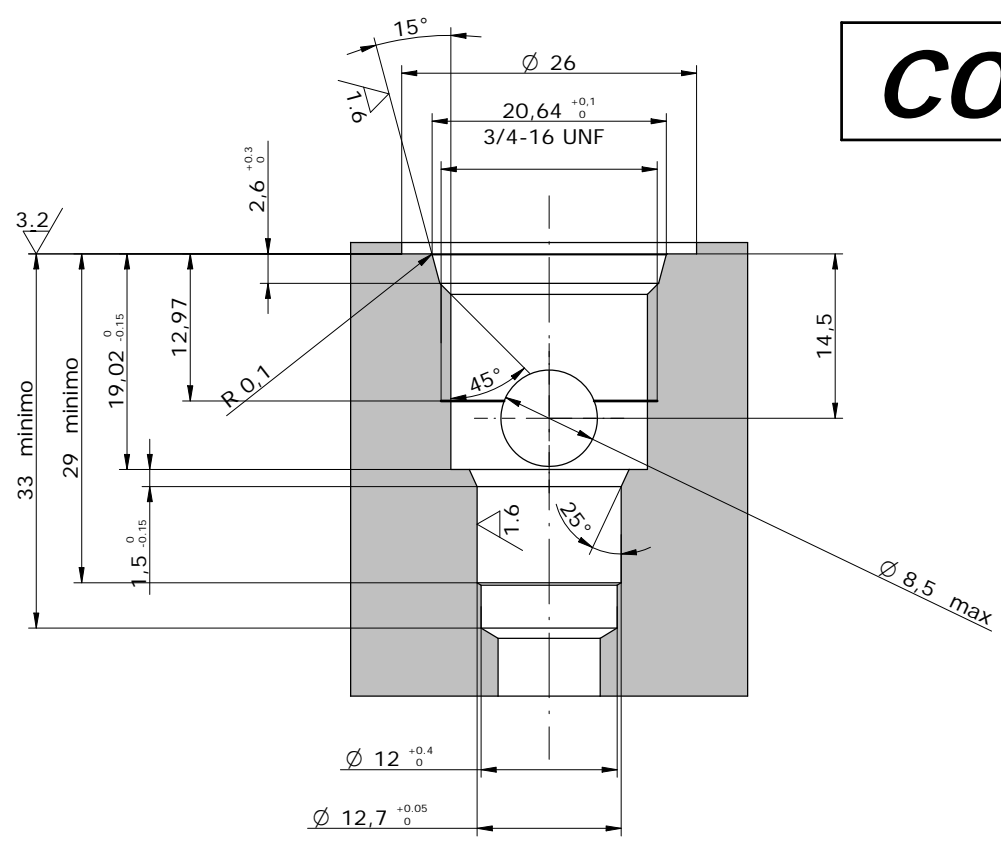

**C008**

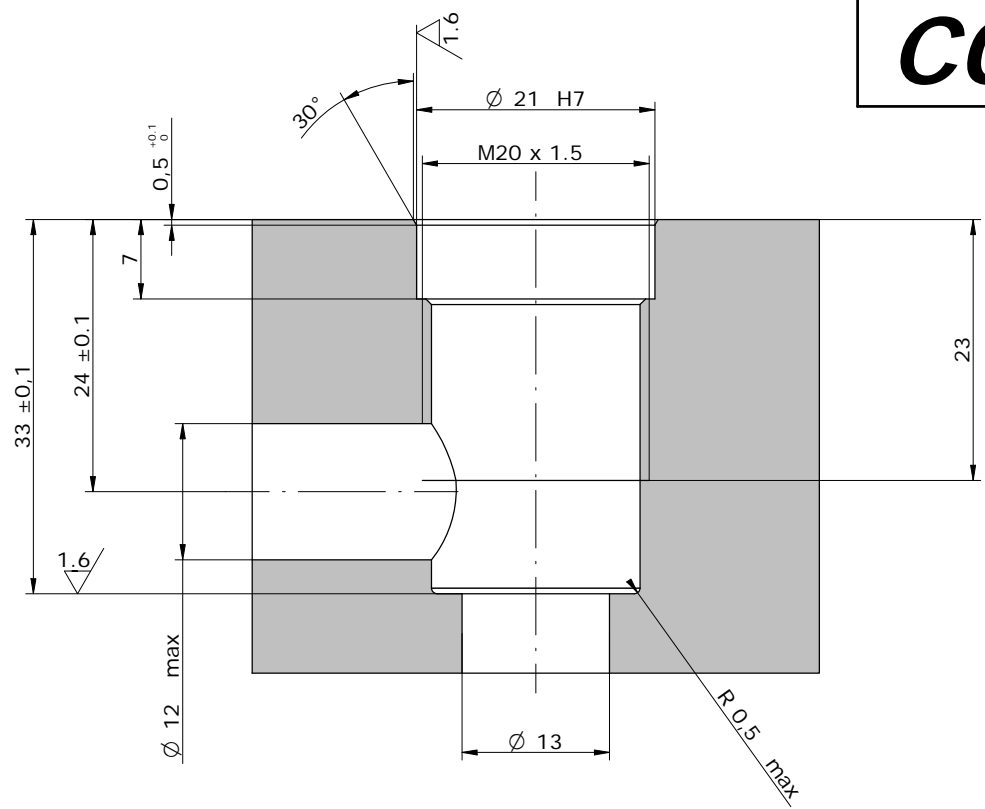



# CAVITY



## C035

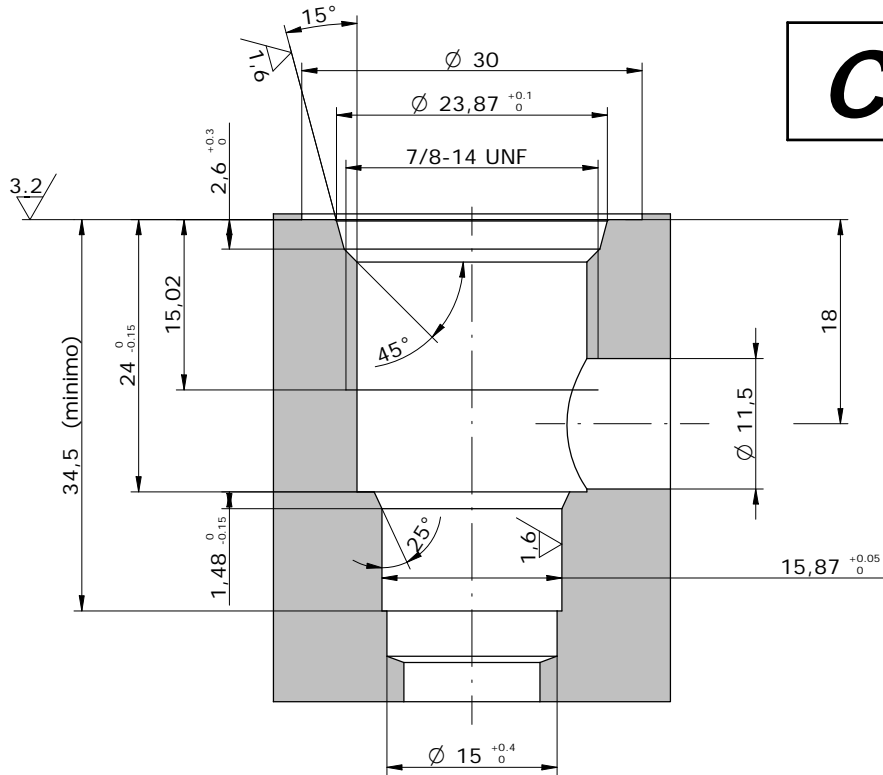

## C045

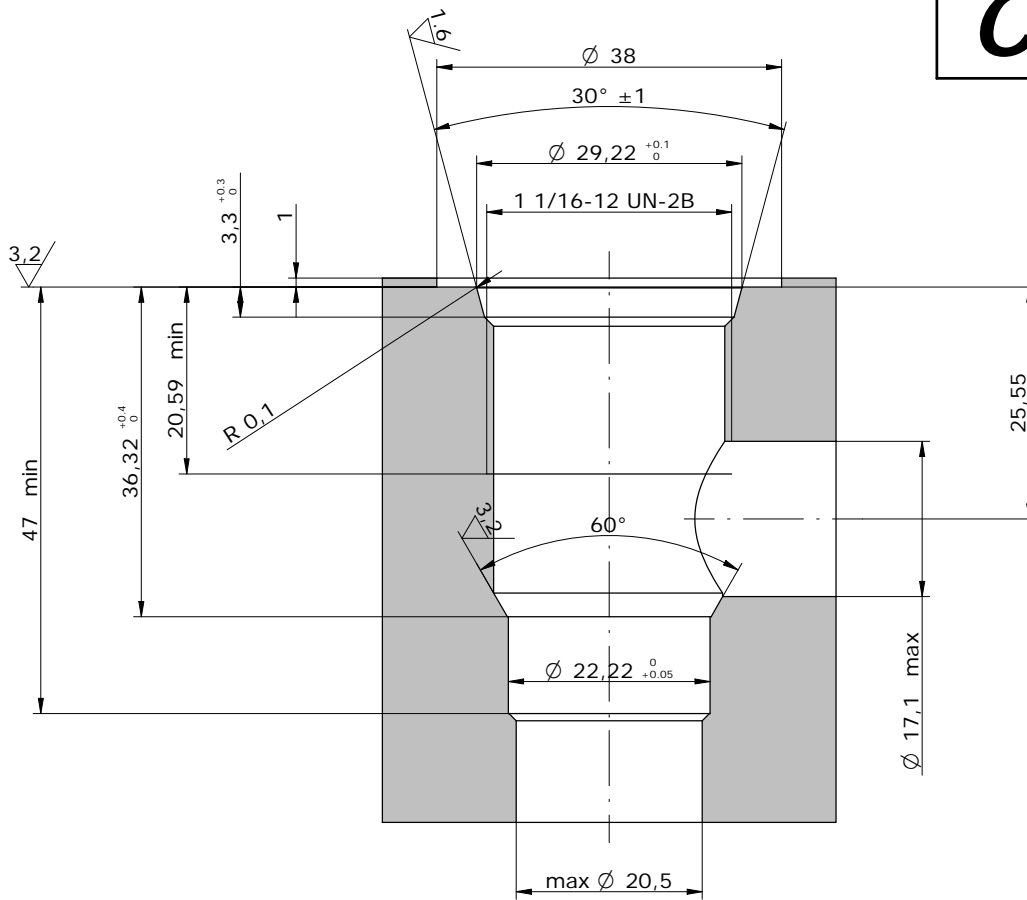

# CAVITY

**C019**

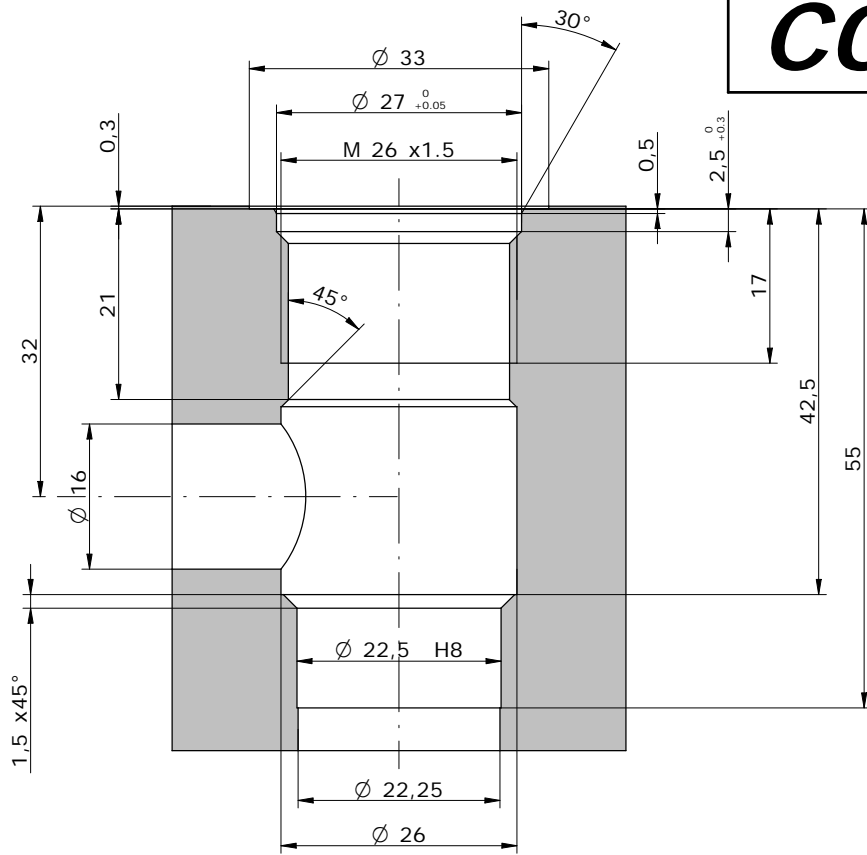

**C025**

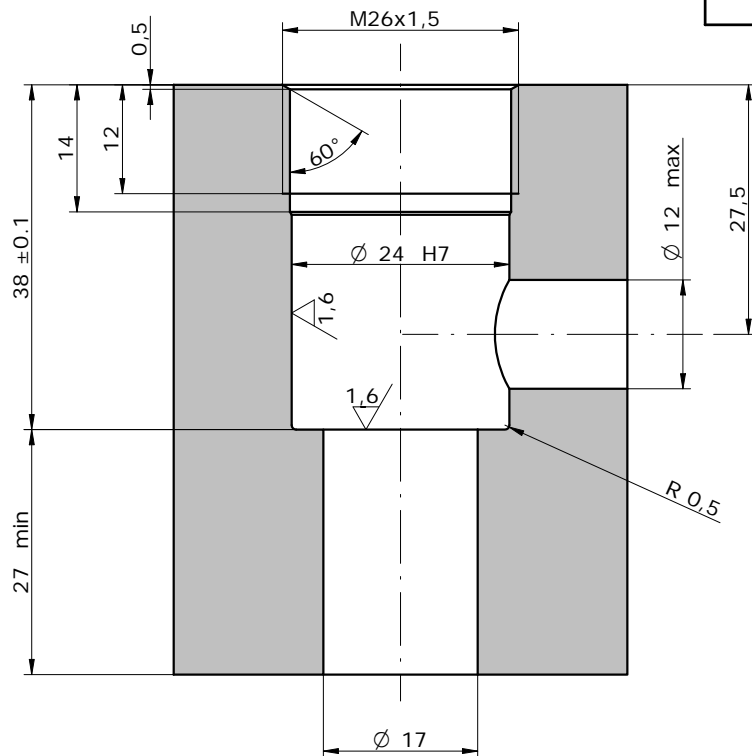

# CAVITY



**BSP 1/8G**

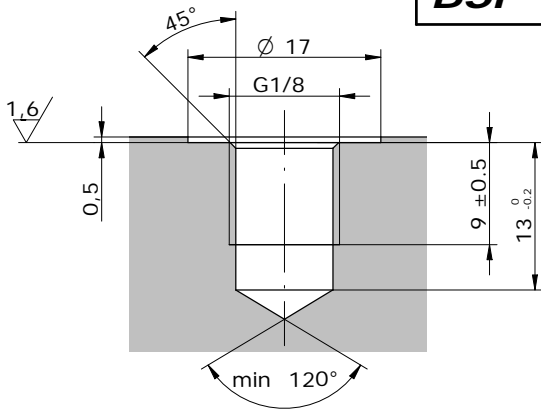

**BSP 1/4G**

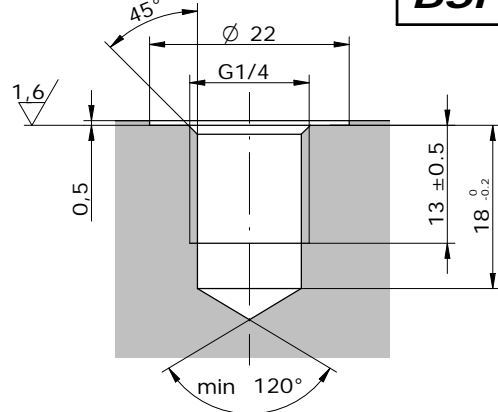

**BSP 3/8G**

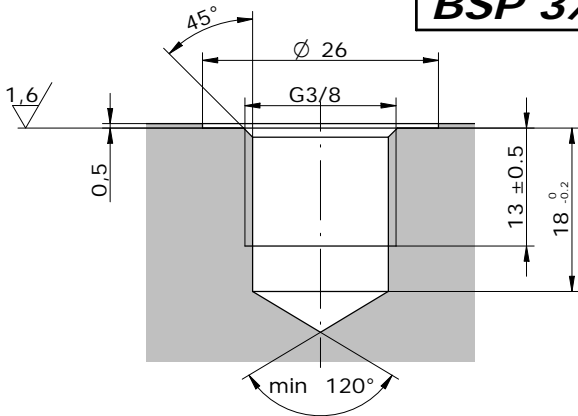

**BSP 1/2G**

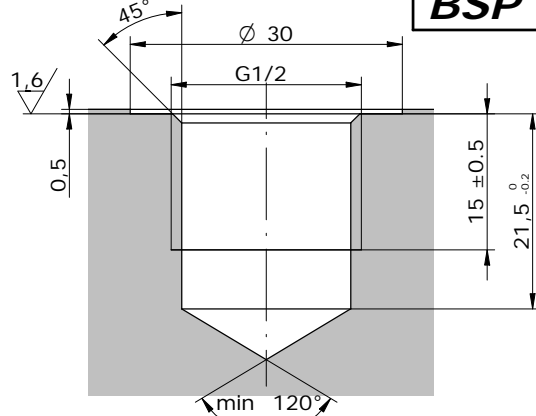

**BSP 3/4G**

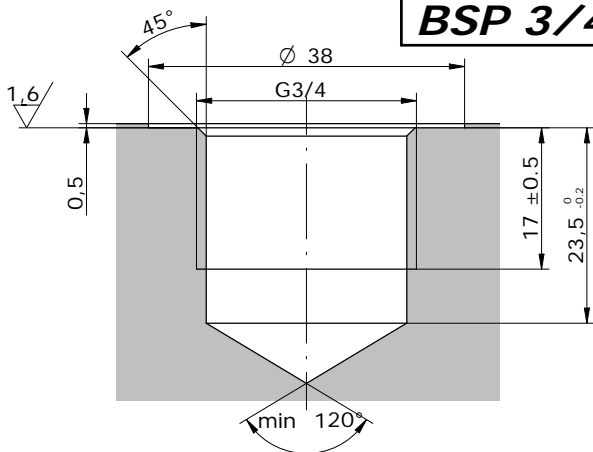

**BSP 1G**

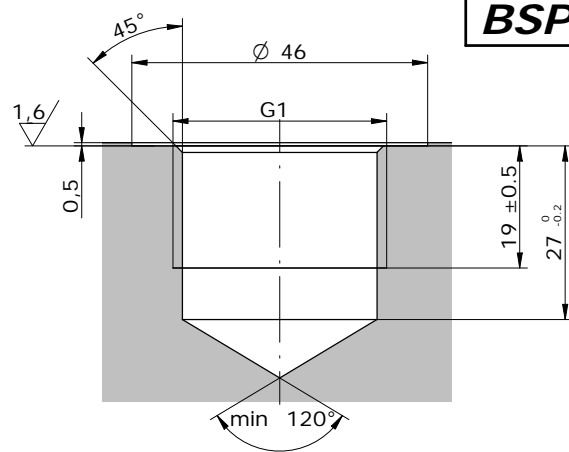

**BSP 1.1/4G**

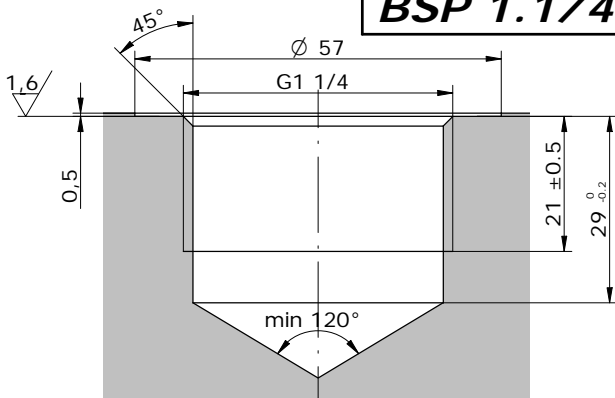

**BSP 1.1/2G**

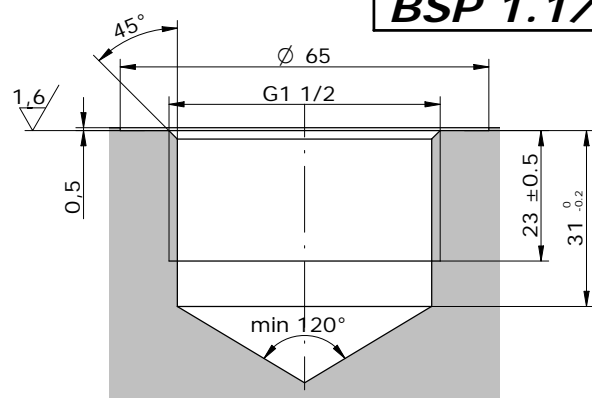

---

**Note - Notes**

A series of 20 horizontal dashed lines for writing notes.



---

***Note - Notes***

A series of 25 horizontal dashed lines for writing notes.

